



UPS-PL

UPS Pro™ Outdoor UPS System

- Wireless Base Stations and Client Devices
- Surveillance Cameras
- Mission Critical Backup Power
- Remote Sensors



Congratulations! on your purchase of the UPS Pro™ Outdoor UPS backup power system. Please take a moment to review this Qwik Install Guide before assembly or battery installation.



DANGER! Avoid Powerlines! You Can Be Killed!

When following the instructions in this guide take extreme care to avoid contact with overhead power lines, lights and power circuits. Contact with power lines, lights or power circuits may be fatal. We recommend to install no closer than 20 feet to any power lines.

Safety: For your own protection, follow these safety rules.

- **Perform as many functions as possible on the ground**
- **Do not attempt to install on a rainy, windy or snowy day or if there is ice or snow accumulation at the install site or if the site is wet.**
- **Make sure there are no people, pets, etc. below when you are working on a roof or ladder.**



Recommended Tools: Phillips Screwdriver, 7mm Open End Wrench, Soldering Iron & Solder (for solar panel)



Please help preserve the environment and return used batteries to an authorized depot

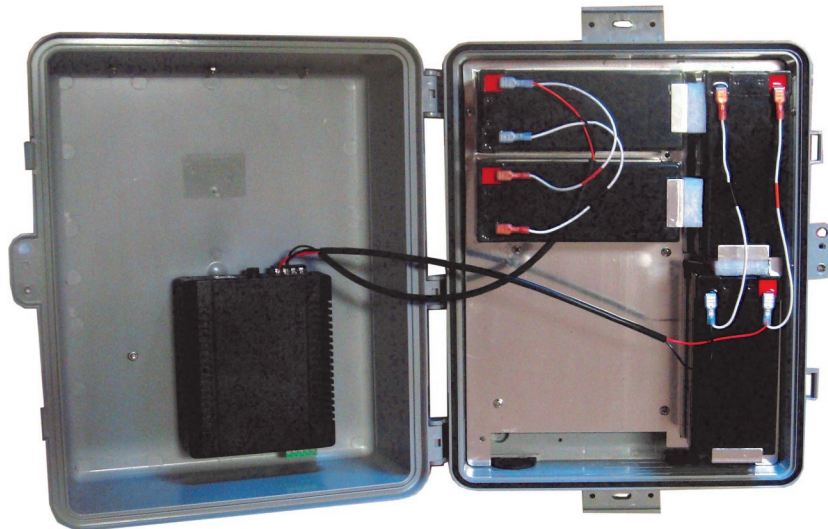

Qwik Install

STEP 1: The UPSPro™ is Solar Ready™ so a solar panel can be added at any time to provide supplemental or full time power.

STEP 2: Install controller to inside cover of housing using Velcro tape. Be sure that controller doesn't interfere with batteries when cover is closed. Mount all the way to lower right corner to give room for CAT5 cables.

STEP 3: Mount any electronics boards to the metal plate. Install a CAT5 cable between the controller POE OUT and the electronics. There is a secondary voltage output on the back of the controller which can be used in addition to the POE OUT. The secondary output is equal to the battery voltage.

STEP 4: Install the enclosure to a pole using stainless steel hose clamps or to a wall using lag bolts.

STEP 5: Install batteries to enclosure with battery terminals on the left and towards the top.

STEP 6: Connect the Battery cables to Controller BAT terminals. Be sure to observe polarity. Black wire connects to battery negative terminal and BAT(-) terminal on the controller. When a fully charged battery is connected, the Green LOA LED should light on controller. Power should also be present at the POE output and the green secondary power output.

STEP 7: Install CAT5 cable between POE inserter/Power Supply inside building and the UPS Pro™ unit controller RJ45 IN connector. It is

highly recommended to protect electronics from lightning/surge damage that the power supply be plugged into a surge protected outlet inside the building.

STEP 8: Make sure lid gasket is clean and free from any particles, then carefully close the cover, making sure that wires are clear of the seam and hinge area. The cover snaps into place.

There is one center security bolt that can be used to secure the cover.

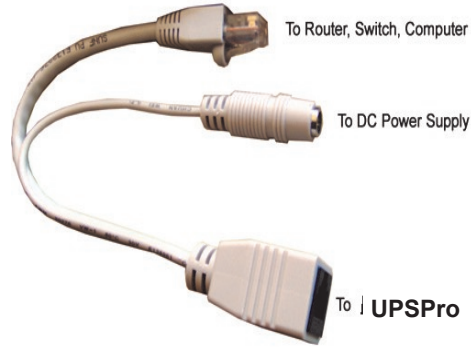

NOTE: If you have any unconnected battery connectors on battery cable after installation, make sure they are wrapped with electrical tape so that there is no chance of shorting the connector to any metal. You can also remove the extra cable/connector permanently by cutting the cable at the existing battery connection.

12V Battery Configuration

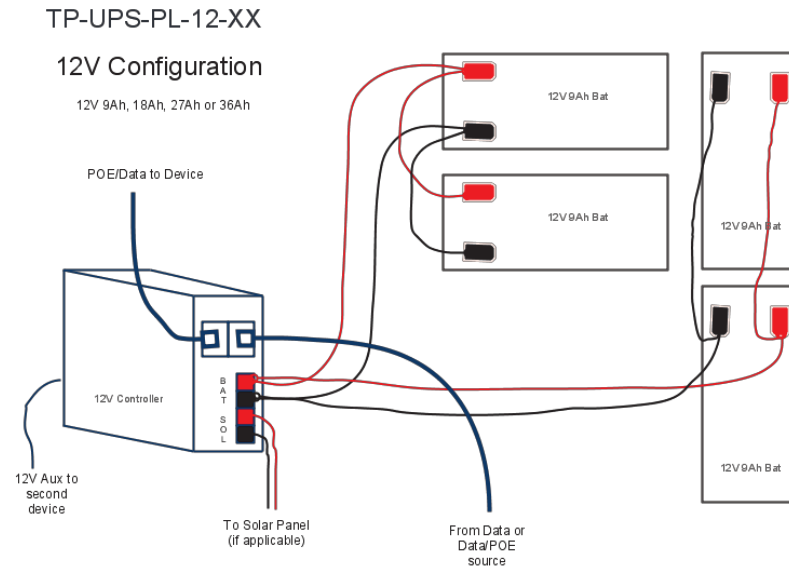

SPECIFICATIONS

Subject to change without notice

Battery Voltage (DC)	12V or 24V
POE Output Voltage (DC)	12V, 18V, 24V or 48V
Maximum POE Input Voltage (DC)	57V
Capacity	9Ah to 36Ah
Battery Type	Valve Regulated Sealed Lead Acid / Absorbent Glass Mat (AGM)
Battery Life	5 Years
Controller Type	Dual Input Solar/POE, PWM, Choice of 12V or 24V 5A <i>Max Solar Panel Size 85W</i>
Overcharge Protection	14.4V / 28.6V
Over-discharge protection	11V / 22V
Over-discharge recovery voltage	12V / 24V
Controller Self Consumption	<0.5W
POE Power Supply	24V / 48V 60W
Enclosure Type	Polycarbonate
Enclosure External Size	17.5 x 12.5 x 6" (445 x 318x 152mm)
Enclosure Internal Size	14 x 10 x 5" (356 x 254 x 127mm)
Space for Customer Electronics	7 x 7 x 4" (177 x 177 x 102mm)
Operating Temperature	-30°C to +60°C
System Weight (without batteries)	4lb (1.8kg)
Battery Weight (each)	2.5kg (5.5lb)

5. **SOLAR PANEL:** The controller used in the UPS-PL can handle a maximum panel size of 135W. Do not exceed 8A into the SOL input or damage to the controller can occur. When the solar panel is generating power, the SOL input will take priority and the POE input will not be used to charge the battery. When the solar panel isn't generating power then the battery will be charged from the POE input.

6. **SOLAR PANEL ANGLE:** Solar panel angle should be adjusted to optimize output. Optimum angle is based on location longitude and is different if summer or winter. If the panel won't have seasonal adjustment, set for winter angle and leave this setting year round. See tyconpower.com/learning_center for additional information. If you are planning to keep solar panel angle fixed all year then set the angle to $\text{Your_Latitude} * 0.9 + 30$

7. **BATTERY HOOKUP:** Always connect the battery first and disconnect the battery last. The controller should not be run without a battery connected.

8. **BATTERY MAINTENANCE:** The batteries used in the UPSPro systems don't require any maintenance. They should last up to 5 years in normal use.

9. **BATTERY OVERDISCHARGE:** We highly recommend hooking all equipment loads to the controller voltage output. This output will disconnect the load if the battery voltage drops below 11V and this will protect the battery from over-discharge. If batteries get completely discharged because the equipment was connected directly to the battery, you will reduce the battery life and you will most likely need to supercharge them with a good quality 10A automotive battery charger. Once they are back to a normal operating range, the integrated charge controller will maintain the charge.

10. **DUAL OUTPUTS:** The UPS-PL has a POE output which can be 12V, 18V, 24V or 48V depending on which model is purchased. There is also an auxiliary protected output on the back of the controller to supply 12VDC. This is useful for applications requiring 2 different voltages.

11. **POE SWITCH:** Tycon Power offers a universal voltage 5port and 8port POE switch if more than one device needs to be powered from the battery system. The **TP-SW5-NC** and **TP-SW8-NC** offer the unique feature that the voltage supplied to the switch is the POE voltage sent to the devices. So 12VDC in and you get 12VDC POE to the devices. The operating voltage is 12V to 56VDC.

12. **OTHER ACCESSORIES:** Tycon also offers a variety of voltage conversion products to meet almost any need. Just visit tyconpower.com for more info.

Limited Warranty

The UPS Pro™ products are supplied with a limited 24 month warranty which covers material and workmanship defects. This warranty does not cover the following:

- Parts requiring replacement due to improper installation, misuse, poor site conditions, faulty power, etc.
- Lightning or weather damage.
- Physical damage to the external & internal parts.
- Products that have been opened, altered, or defaced.
- Water damage for units that were not mounted according to user manual.
- Usage other than in accordance with instructions and the normal intended use.

