



**BreezeACCESS<sup>®</sup> VL**

**System Manual**

**PRELIMINARY**

**SW Version 5.1  
March 2009  
P/N**

## Document History

Topic	Description	Version/Date Issued
FIPS 197 Sections: 4.2.5.7.3, 4.2.6.7	Optional support (under license) of FIPS 197 compliant encryption	SW Version 4.0, July 2006
4.9 GHz B&B models Section: 1.4, 1.7.1, 1.7.5.1.1, 1.7.5.4.1	AU/SU with 25dBi antennas for point-to-point links in the 4.9 GHz band	SW Version 4.0, July 2006
AUS functionality change Section: 1.2, 4.2.6.2.12	AUS can support up to 8 SU-3/SU-6 units (increased from 5)	SW Version 4.0, July 2006
IDU-ODU Cable Section 2.1.2	Update of maximum length of IDU-ODU cable	SW Version 4.0, July 2006
Frequency configuration Section 4.2.6.2.3.1, 4.2.6.2.5	Improved mechanism for automatic detection of frequency/bandwidth. Removed parameters: Sub Band select (SU), Frequency Subset Definition (SU). New parameters: User Defined Frequency Subsets.	SW Version 4.0, July 2006
Transmit Power, Maximum Transmit Power Section 4.2.6.2.8	Simplified configuration mechanism: A single parameter instead of per-modulation level parameters.	SW Version 4.0, July 2006
5.3 FCC limitations Section 4.2.6.2.4.1	Update Tx Power limitations for compliance with FCC regulations	SW Version 4.0, July 2006
Per SU Distance Learning Section 4.2.5.7.2, 4.2.6.2.10	New feature	SW Version 4.0, July 2006
ATPC Delta from Minimum SNR Level Section 4.2.6.2.8.3.3	Default values updated	SW Version 4.0, July 2006
Tx Control Section 4.2.6.2.8.5	Added option: Ethernet Status Control	SW Version 4.0, July 2006
Lost Beacons Transmission Watchdog Threshold Section 4.2.6.2.15	New feature	SW Version 4.0, July 2006

Topic	Description	Version/Date Issued
Service Provider Link (VLAN QinQ) Section 4.2.6.4.1	New feature Service Provider Link option added to VLAN Link Type. New parameters: Service Provider VLAN ID, VLAN QinQ Protocol Ethertpe.	SW Version 4.0, July 2006
MAC Address List Section 4.2.6.4.7	Improved functionality. New parameter: MAC Address List Action	SW Version 4.0, July 2006
Concatenation Section 4.2.6.5.9	Improved mechanism. New parameter: Maximum Concatenated Frame Size. Removed: Maximum Number of Frames	SW Version 4.0, July 2006
MIR Table 4-14,	Changes in values of Downlink MIR for SU-3, SU-6	SW Version 4.0, July 2006
IP Precedence Threshold Section 4.2.6.6.3.2.2	Default value updated	SW Version 4.0, July 2006
DSCP Threshold Section 4.2.6.6.3.2.3	Default value updated	SW Version 4.0, July 2006
Low Priority Traffic Minimum Percent Section 4.2.6.6.3.4	New feature	SW Version 4.0, July 2006
DRAP support Section 4.2.6.6.4	New feature	SW Version 4.0, July 2006
Gateways Table Section 4.2.5.4.1	New – display of existing gateways when DRAP is enabled.	SW Version 4.0, July 2006
Wireless Link Prioritization Section 4.2.6.6.3.5	New feature	SW Version 4.0, July 2006
FTP Client IP Address Sections 4.2.3.11, 4.2.3.12	Changed functionality (read only, set to unit's IP Address)	SW Version 4.0, July 2006
FTP Server IP Address Sections 4.2.3.11, 4.2.3.12, 4.2.3.9.4	Changed default to 10.0.0.253	SW Version 4.0, July 2006
Number of HW Retries Section 4.2.6.5.6	Maximum value was changed from 15 to 14	SW Version 4.0, July 2006

Topic	Description	Version/Date Issued
Ethernet packet length Section 4.2.5.1.1	Updated maximum length	SW Version 4.0, July 2006
Basic Parameters Table Table 3-1	Updated according to applicable changes (new/removed parameters)	SW Version 4.0, July 2006
Parameters that are not reset to default value after Set Complete Factory/Operator Defaults Table 4-2	Updated according to applicable changes (new/removed parameters)	SW Version 4.0, July 2006
Parameters that are not reset to default value after Set Partial Factory/Operator Defaults Table 4-3	Updated according to applicable changes (new/removed parameters)	SW Version 4.0, July 2006
Basic Configuration Menu Section 4.2.4	Updated according to applicable changes (new/removed parameters)	SW Version 4.0, July 2006
MIB (Appendix E)	Updated according to applicable changes (new/removed parameters)	SW Version 4.0, July 2006
Parameters Summary (Appendix F)	Updated according to applicable changes (new/removed parameters)	SW Version 4.0, July 2006
Using the Feature License Web Application	Removed (previously Appendix G) – Available as a separate document.	SW Version 4.0, July 2006
New Subscriber Unit: SU-A-ODU	Added New SU-A-ODU and accessories	SW Version 4.0 Rev. B August 2006
New Subscriber Unit: SU-I	Added new unit – SU-I, and accessories	SW Version 4.0 Rev. C August 2006
SU-A-H removed Sections 1.3.1, 1.7.1, 1.7.5.1.1, 2.1.1.1	SU-A-H (SU with horizontally polarized integrated antenna) was removed from products list)	SW Version 4.0.27 October 2006
IDU PS1036 removed from Manual. Sections 1.7.5.1, 1.7.5.4, 2.4, 3.5.2	Replaced by PS1073	SW Version 4.0.27 October 2006

Topic	Description	Version/Date Issued
Q in Q (Service Provider Link) improvements. Sections 4.2.6.4.1.2, 4.2.6.4.1.3.4, 4.2.6.4.1.8, MIB (Appendix E), Parameters Summary (Appendix F)	Improved handling of management frames. Support of Ethertypes 9100, 9200 (hex).	SW Version 4.0.27 October 2006
DRAP UDP Port Section 4.2.6.6.4.2, Parameters Summary (Appendix F)	Default changed to 8171	SW Version 4.0.27 October 2006
MIR/CIR parameters of SU-I Table 4-14, Table 4-15, MIB (Appendix E), Parameters Summary (Appendix F)	Updated	SW Version 4.0.27 February 2007
AUS supports also SU-I Section 1.2	Updated functionality	SW Version 4.0.27 February 2007
Password Recovery Section 4.1.1	New feature – a procedure for password recovery if password was lost/forgotten.	SW Version 4.0.27 February 2007
AP Client IP Address Sections 4.2.6.3.8, Table 4-3, MIB (Appendix E), Parameters Summary (Appendix F)	New feature	SW Version 4.0.27 February 2007
Noise Immunity Control Sections 4.2.6.2.17, Table 4-3, Parameters Summary (Appendix F)	New feature	SW Version 4.0.27 February 2007
Show Unit Status Section 4.2.2.1	Added Country Code, Serial Number and ATE Test Status	SW Version 4.5 June 2007
Wireless Rx Events Section 4.2.5.1.2	Added Other counter	SW Version 4.5 June 2007
Broadcast Relaying Section 4.2.6.4.5, Parameters Summary (Appendix E)	New functionality. Name changed from Broadcast Relaying to Broadcast/Multicast Relaying.	SW Version 4.5 June 2007

Topic	Description	Version/Date Issued
MIR Threshold Percent Sections 4.2.6.6.2, 4.2.6.6.2.9, Parameters Summary (Appendix E)	New MIR/CIR parameter	SW Version 4.5 June 2007
Station Allowed Option Section 4.2.6.4.7, 4.2.6.4.7.4, Parameters Summary (Appendix E)	New feature	SW Version 4.5 June 2007
Antenna Compliance Statement (in Legal Rights)	New	SW Version 4.5 June 2007
Transmit Power Compliance With Regulations Section 3.1.2	New	SW Version 4.5 June 2007
MIB Appendix (previously Appendix E)	Removed (all information is available in the MIB text file)	SW Version 4.5 June 2007
Minimum and Maximum Contention Window parameters Run-Time Update definition, Parameters Summary (Appendix E)	Parameters are not Run-Time Updated (reset required)	SW Version 4.5 June 2007
Maximum uplink data rate of SU-I has been changed Table 4-14, Table 4-15, Parameters Summary (Appendix E)	Maximum values of Uplink CIR and MIR, and default value of Uplink MIR, has been changed from 2048 Kbps to 4096 Kbps	SW Version 4.5 July 2007
SU “aging” mechanism (removal from Association Database) Sections 4.2.2.1, 4.2.5.4.1, 4.2.6.2.12	Updated	SW Version 4.5 July 2007
Pulse Detection Sensitivity Section 4.2.6.2.17.5, Parameters Summary (Appendix E)	Default has been changed to Low	SW Version 4.5 July 2007
Range of supported modulation levels Sections 4.2.6.5.3, 4.2.6.5.4	Updated description	SW Version 4.5 July 2007

Topic	Description	Version/Date Issued
Default value of DFS Minimum Pulses to Detect Section 4.2.6.2.4.3.6, Parameters Summary (Appendix E)	4 for FCC, 8 for other (ETSI)	SW Version 4.5 July 2007
FCC Radiation Hazard Warning (in Legal Rights)	Updated	SW Version 4.5 July 2007
Usable frequencies limitations Section 4.2.6.2.4.2	Updated	SW Version 4.5 July 2007
Re-apply Country Code Values Section 4.2.6.8.2, Appendix A	New feature	SW Version 4.5 July 2007
Basic Parameters Section 4.2.4	Added AP Client IP Address	SW Version 4.5 July 2007
DFS Section 4.2.6.2.4.3.1	Name changed from DFS Option to DFS Required by Regulations (No/Yes)	SW Version 4.5 July 2007
Sub-Band Select in SU Sections 4.2.6.2.5.1, 4.2.6.2.14	Added/updated descriptions	SW Version 4.5 July 2007
MIR/CIR Parameters Section 4.2.6.6.2	Improved description	SW Version 4.5 August 2007
Frequency Ranges Table 1-1, Table 1-7	The 5.8 GHz band is up to 5.875 GHz (actual usable frequencies depend on Country Code)	SW Version 4.5 August 2007
Antenna specifications Table 1-7	Updated compliance to ETSI standard (EN 302 326-3 V1.2.1 (2007-01))	SW Version 4.5 August 2007
Limitations on usable frequencies in FCC 5.3 GHz band Sections 3.1.2, 4.2.6.2.4.2	Updated	SW Version 4.5 August 2007
Correct Run-Time update of Unit Control Parameters Appendix E - Parameters Summary, Section E.1.1	FTP Server IP Address, FTP Gateway IP Address, FTP User Name, FTP Password are updated in run-time (reset not required)	SW Version 5.0 November 2007

Topic	Description	Version/Date Issued
Correct Run-Time update of Air Interface Parameters Appendix E - Parameters Summary, Section E.1.3	Preferred AU MAC Address, Arbitration Inter-Frame Spacing, Wireless Trap Threshold are not updated in run-time (reset is required). Sub-Band Select, Frequency, DFS Required by Regulations, Frequency Subset Definition, Channel Check Time, Channel Avoidance Period, SU Waiting Option, Minimum Pulses to Detect, Channel Reuse Option, Radar Activity Assessment Period, Maximum Number of Detections in Assessment Period, are updated in run-time (reset is not required). Spectrum Analysis parameters are applicable in run-time (configured per test)	SW Version 5.0 November 2007
Correct Run-Time update of Service Parameters Appendix E - Parameters Summary, Section E.1.7	MIR: Downlink, MIR: Uplink, CIR: Downlink, CIR: Uplink, Maximum Burst Duration, MIR Threshold Percent, are updated in run-time (reset is not required).	SW Version 5.0 November 2007
Send Traps Section 4.2.6.3.7	Traps are generated and sent only by AU (including traps on behalf of associated SUs)	SW Version 5.0 November 2007
Unit Control Menu Section 4.2.3	Re-apply Country Codes Values option has been removed (available in Basic and Advanced Configuration, Country Code Parameters).	SW Version 5.0 November 2007
Wi2 IP Address Section 4.2.6.3.8	Updated name (was previously AP Client IP Address)	SW Version 5.0 November 2007
Basic Configuration Menu Section 4.2.4	Added Country Code Parameters	SW Version 5.0 November 2007
Country Code Parameters Sections 4.2.6.8, 3.1.2, Table 3-1	New	SW Version 5.0 November 2007
SU-3 and SU-6 units Section 1.3.1	Starting on SW Version 5.0, all units will support a full LAN	SW Version 5.0 November 2007
AUS Sections 1.2.1, 1.2.2	An optional license enables support of SU-54 units	SW Version 5.0 November 2007
SU "aging" mechanism (removal from Association Database) Sections 4.2.2.1, 4.2.5.4.1, 4.2.6.2.12	Updated	SW Version 5.0 November 2007

Topic	Description	Version/Date Issued
Maximum Number of Associations with Data Encryption enabled Sections 4.2.6.2.12, 4.2.6.7.2	Maximum Number of Associations must be set to 124 or lower to enable Data Encryption	SW Version 5.0 November 2007
MIR and CIR Parameters Section 4.2.6.6.2	Updated description of Burst Duration algorithm	SW Version 5.0 November 2007
RTS Threshold Section 4.2.6.5.1	For HW Rev C and higher, the maximum is 4092 bytes. This is also the default for RTS Threshold in AU.	SW Version 5.0 November 2007
MAC Address Database in AU Section 4.2.5.4.1	Updated the information displayed in the various options	SW Version 5.0 November 2007
MAC Address Database in SU Section 4.2.5.4.2	Updated the displayed information	SW Version 5.0 November 2007
Menu header Section 4.1.1	Updated details of Menu header	SW Version 5.0 November 2007
Country Code Learning by SU Section 4.2.6.2.4.5	The SU will learn a new Country Code only if it is running from the Main version. The default has been changed to Disable.	SW Version 5.0 November 2007
Show Unit Status Section 4.2.2.1	New read-only indications: <ul style="list-style-type: none"> <li>■ SU-54 Support (AUS)</li> <li>■ Wireless Link Prioritization Support (AU)</li> </ul>	SW Version 5.0 November 2007
Management Solutions Section 1.6.1	BreezeCONFIG has been replaced by AlvariCRAFT	SW Version 5.0 November 2007
Set Complete/Partial Defaults Table 4-2, Table 4-3	Selected Country Code does not change after Set Complete/Partial Defaults	SW Version 5.0 November 2007
Feature License Section 4.2.3.10	Added note on potential copy/paste problems	SW Version 5.0 November 2007
AIFS Section 4.2.6.2.11	Range has been increased from 1-2 to 1-50 time slots.	SW Version 5.0 November 2007
Data Encryption Option Section 4.2.6.7.2	AU with Data Encryption Option enabled can accept non-encrypted data frames (previously it was stated that this is applicable only for SU)	SW Version 5.0 December 2007

<b>Topic</b>	<b>Description</b>	<b>Version/Date Issued</b>
Low Priority AIFS Section 4.2.6.6.3.5.2	The range has been changed from 3-254 to 3-50.	SW Version 5.0 December 2007
MIR Defaults Table 4-14	Default value for SU-54 have been updated (53,888)	SW Version 5.0 December 2007
Regulation Max EIRP Table 3-2	Updated (New Country Codes, updated values for UK 5.8 GHz)	SW Version 5.0 December 2007
Scanning Mode Section 4.2.6.2.7	Updated description (set to passive if DFS supported by Country Code)	SW Version 5.0 December 2007
Pulse Detection Sensitivity Section 4.2.6.2.17.5	Updated description.	SW Version 5.0 December 2007
Noise Immunity Control Section 4.2.6.2.17	Updated: Available only in units with HW Revision C and higher, except to Pulse Detection Sensitivity that is available also in units with HW Revision B.	SW Version 5.0 December 2007
Antenna Gain Section 4.2.6.2.9	Range updated.	SW Version 5.0 December 2007
900 MHz Band Sections 1.2.1, 1.2.2, 1.3.1, 2.1.1.1, 2.1.1.4, 2.3.2, 2.3.5.3, 3.2, Table 1-1, Table 1-7, Table 1-11, Table 1-12, Table 1-16, Table 1-19, Table 3-2	New Radio Band and relevant products	SW Version 5.1 April 2008
Protecting ODU Connections Section 2.3.3	New	SW Version 5.1 April 2008
MAC Address Database in AU, Section 4.2.5.4.1	In Display Association Info, RSSI info has been added (per SU)	SW Version 5.1 April 2008
Continuous Noise Floor Display, Sections 4.2.5.3.2 (SU), 4.2.5.5 (AU)	New feature	SW Version 5.1 April 2008
Continuous Average SNR/RSSI Display in SU, Section 4.2.5.3.1	Average RSSI has been added to the display. Added formula used for calculations.	SW Version 5.1 April 2008
Spectrum Analysis Information Display, Section 4.2.6.2.14.6	Added new parameters (OFDM SNR, OFDM Max SNR, Noise Floor Avg, Noise Floor Max)	SW Version 5.1 April 2008

Topic	Description	Version/Date Issued
Show Spectrum Analysis Parameters & Data, Section 4.2.6.2.14.8	Updated manual	SW Version 5.1 April 2008
Show Best AU Parameters and Data, Section 4.2.6.2.6.4	RSSI of the received signal has been added	SW Version 5.1 April 2008
ATPC Delta from Minimum SNR Level, Section 4.2.6.2.8.3.3	Added default value for 0.9 GHz band	SW Version 5.1 April 2008
MIR/CIR ranges and defaults, Table 4-14, Table 4-15	Added values for SU-8	SW Version 5.1 April 2008
SU-54 Support, SU-8 Support, Section 4.2.2.1	Updated description of SU-54 Support by AUS. AUS can support also SU-8 (new product).	SW Version 5.1 April 2008
RTS Threshold Section 4.2.6.5.1	Default value for AU in the 900 MHz band is 60	SW Version 5.1 April 2008
New SU-A-ODU Figure 2-3	Updated	SW Version 5.1 April 2008
AU types Sections 1.2, 1.7.1, 1.7.5.3, 1.7.5.4, 2.1.1.2.2, 2.1.1.3	AU-D models (supplied with a detached antenna) are no longer available. Only AU-E models are available (antennas are sold separately)	SW Version 5.1 April 2008
Noise Floor Calculation Section 4.2.6.2.18, Table 4-3	New feature	SW Version 5.1 April 2008
Appendix E - Parameters Summary	Updated to reflect relevant changes	SW Version 5.1 April 2008
AU-ODU types Table 1-2, Table 2-2, Table 2-3	New tables reflecting the new 0.9 MHz AU ODU.	SW Version 5.1 June 2008
SU-ODU types Table 1-4, Table 2-1	Updated (more details)	SW Version 5.1 June 2008
AU-E-ODU mechanical specifications Table 1-16, Table 1-19	Updated to reflect new 0.9 GHz AU-ODU	SW Version 5.1 June 2008

Topic	Description	Version/Date Issued
Packing Lists Sections 2.1.1.2.2, 2.1.1.3, 2.1.1.4	Updated to reflect new 0.9 GHz AU-ODU	SW Version 5.1 June 2008
ODU Installation Section 2.3	Updated to reflect new 0.9 GHz AU-ODU	SW Version 5.1 June 2008
Maximum Output Power Table 1-7	Updated (27 dBm for 0.9 GHz units)	SW Version 5.1 June 2008
RESET Button Functionality Section 2.4.1	Updated	SW Version 5.1 June 2008
Association Database in AU Sections 4.2.2.1, 4.2.5.4.1, 4.2.6.2.12	Updated: Association SNAP from another AU is not used for removal of SU from the database.	SW Version 5.1 June 2008
SU Unit Status Section 4.2.2.1	Updated (added AUTHENTICATING status)	SW Version 5.1 June 2008
MAC Address List Section 4.2.6.4.7	Corrected (supplier's OUI is 00-10-E7)	SW Version 5.1 June 2008
File Loading Appendix B	Updated: A known parameter with a value that is invalid or out of range will be ignored	SW Version 5.1 June 2008
Ethernet Port Connection Problems Section F.1	Updated	SW Version 5.1 June 2008

## Legal Rights

© Copyright 2008 Alvarion Ltd. All rights reserved.

The material contained herein is proprietary, privileged, and confidential and owned by Alvarion or its third party licensors. No disclosure thereof shall be made to third parties without the express written permission of Alvarion Ltd.

Alvarion Ltd. reserves the right to alter the equipment specifications and descriptions in this publication without prior notice. No part of this publication shall be deemed to be part of any contract or warranty unless specifically incorporated by reference into such contract or warranty.

## Trade Names

Alvarion®, BreezeCOM®, WALKair®, WALKnet®, BreezeNET®, BreezeACCESS®, BreezeMANAGE™, BreezeLINK®, BreezeCONFIG™, BreezeMAX™, AlvariSTAR™, BreezeLITE™, AlvariCRAFT™, MGW™, eMGW™ and/or other products and/or services referenced here in are either registered trademarks, trademarks or service marks of Alvarion Ltd.

All other names are or may be the trademarks of their respective owners.

## Statement of Conditions

The information contained in this manual is subject to change without notice. Alvarion Ltd. shall not be liable for errors contained herein or for incidental or consequential damages in connection with the furnishing, performance, or use of this manual or equipment supplied with it.

## Warranties and Disclaimers

All Alvarion Ltd. ("Alvarion") products purchased from Alvarion or through any of Alvarion's authorized resellers are subject to the following warranty and product liability terms and conditions.

### Exclusive Warranty

(a) Alvarion warrants that the Product hardware it supplies and the tangible media on which any software is installed, under normal use and conditions, will be free from significant defects in materials and workmanship for a period of fourteen (14) months from the date of shipment of a given Product to Purchaser (the "Warranty Period"). Alvarion will, at its sole option and as Purchaser's sole remedy, repair or replace any defective Product in accordance with Alvarion's standard R&R procedure.

(b) With respect to the Firmware, Alvarion warrants the correct functionality according to the attached documentation, for a period of fourteen (14) month from invoice date (the "Warranty Period)". During the Warranty Period, Alvarion may release to its Customers firmware updates, which include additional performance improvements and/or bug fixes, upon availability (the "Warranty").

Bug fixes, temporary patches and/or workarounds may be supplied as Firmware updates.

Additional hardware, if required, to install or use Firmware updates must be purchased by the Customer. Alvarion will be obligated to support solely the two (2) most recent Software major releases.

ALVARION SHALL NOT BE LIABLE UNDER THIS WARRANTY IF ITS TESTING AND EXAMINATION DISCLOSE THAT THE ALLEGED DEFECT IN THE PRODUCT DOES NOT EXIST OR WAS CAUSED BY PURCHASER'S OR ANY THIRD PERSON'S MISUSE, NEGLIGENCE, IMPROPER INSTALLATION OR IMPROPER TESTING, UNAUTHORIZED ATTEMPTS TO REPAIR, OR ANY OTHER CAUSE BEYOND THE RANGE OF THE INTENDED USE, OR BY ACCIDENT, FIRE, LIGHTNING OR OTHER HAZARD.

## Disclaimer

(a) The Product is sold on an "AS IS" basis. Alvarion, its affiliates or its licensors MAKE NO WARRANTIES, WHATSOEVER, WHETHER EXPRESS OR IMPLIED, WITH RESPECT TO THE SOFTWARE AND THE ACCOMPANYING DOCUMENTATION. ALVARION SPECIFICALLY DISCLAIMS ALL IMPLIED WARRANTIES OF MERCHANTABILITY AND FITNESS FOR A PARTICULAR PURPOSE AND NON-INFRINGEMENT WITH RESPECT TO THE SOFTWARE. UNITS OF PRODUCT (INCLUDING ALL THE SOFTWARE) DELIVERED TO PURCHASER HEREUNDER ARE NOT FAULT-TOLERANT AND ARE NOT DESIGNED, MANUFACTURED OR INTENDED FOR USE OR RESALE IN APPLICATIONS WHERE THE FAILURE, MALFUNCTION OR INACCURACY OF PRODUCTS CARRIES A RISK OF DEATH OR BODILY INJURY OR SEVERE PHYSICAL OR ENVIRONMENTAL DAMAGE ("HIGH RISK ACTIVITIES"). HIGH RISK ACTIVITIES MAY INCLUDE, BUT ARE NOT LIMITED TO, USE AS PART OF ON-LINE CONTROL SYSTEMS IN HAZARDOUS ENVIRONMENTS REQUIRING FAIL-SAFE PERFORMANCE, SUCH AS IN THE OPERATION OF NUCLEAR FACILITIES, AIRCRAFT NAVIGATION OR COMMUNICATION SYSTEMS, AIR TRAFFIC CONTROL, LIFE SUPPORT MACHINES, WEAPONS SYSTEMS OR OTHER APPLICATIONS REPRESENTING A SIMILAR DEGREE OF POTENTIAL HAZARD. ALVARION SPECIFICALLY DISCLAIMS ANY EXPRESS OR IMPLIED WARRANTY OF FITNESS FOR HIGH RISK ACTIVITIES.

(b) PURCHASER'S SOLE REMEDY FOR BREACH OF THE EXPRESS WARRANTIES ABOVE SHALL BE REPLACEMENT OR REFUND OF THE PURCHASE PRICE AS SPECIFIED ABOVE, AT ALVARION'S OPTION. TO THE FULLEST EXTENT ALLOWED BY LAW, THE WARRANTIES AND REMEDIES SET FORTH IN THIS AGREEMENT ARE EXCLUSIVE AND IN LIEU OF ALL OTHER WARRANTIES OR CONDITIONS, EXPRESS OR IMPLIED, EITHER IN FACT OR BY OPERATION OF LAW, STATUTORY OR OTHERWISE, INCLUDING BUT NOT LIMITED TO WARRANTIES, TERMS OR CONDITIONS OF MERCHANTABILITY, FITNESS FOR A PARTICULAR PURPOSE, SATISFACTORY QUALITY, CORRESPONDENCE WITH DESCRIPTION, NON-INFRINGEMENT, AND ACCURACY OF INFORMATION

GENERATED. ALL OF WHICH ARE EXPRESSLY DISCLAIMED. ALVARION' WARRANTIES HEREIN RUN ONLY TO PURCHASER, AND ARE NOT EXTENDED TO ANY THIRD PARTIES. ALVARION NEITHER ASSUMES NOR AUTHORIZES ANY OTHER PERSON TO ASSUME FOR IT ANY OTHER LIABILITY IN CONNECTION WITH THE SALE, INSTALLATION, MAINTENANCE OR USE OF ITS PRODUCTS.

## Limitation of Liability

(a) ALVARION SHALL NOT BE LIABLE TO THE PURCHASER OR TO ANY THIRD PARTY, FOR ANY LOSS OF PROFITS, LOSS OF USE, INTERRUPTION OF BUSINESS OR FOR ANY INDIRECT, SPECIAL, INCIDENTAL, PUNITIVE OR CONSEQUENTIAL DAMAGES OF ANY KIND, WHETHER ARISING UNDER BREACH OF CONTRACT, TORT (INCLUDING NEGLIGENCE), STRICT LIABILITY OR OTHERWISE AND WHETHER BASED ON THIS AGREEMENT OR OTHERWISE, EVEN IF ADVISED OF THE POSSIBILITY OF SUCH DAMAGES.

(b) TO THE EXTENT PERMITTED BY APPLICABLE LAW, IN NO EVENT SHALL THE LIABILITY FOR DAMAGES HEREUNDER OF ALVARION OR ITS EMPLOYEES OR AGENTS EXCEED THE PURCHASE PRICE PAID FOR THE PRODUCT BY PURCHASER, NOR SHALL THE AGGREGATE LIABILITY FOR DAMAGES TO ALL PARTIES REGARDING ANY PRODUCT EXCEED THE PURCHASE PRICE PAID FOR THAT PRODUCT BY THAT PARTY (EXCEPT IN THE CASE OF A BREACH OF A PARTY'S CONFIDENTIALITY OBLIGATIONS).

## Electronic Emission Notices

This device complies with Part 15 of the FCC rules.

Operation is subject to the following two conditions:

- 1 This device may not cause harmful interference.
- 2 This device must accept any interference received, including interference that may cause undesired operation.

## FCC Radio Frequency Interference Statement

The Subscriber Unit equipment has been tested and found to comply with the limits for a class B digital device, pursuant to part 15 of the FCC rules and to ETSI EN 301 489-1 rules. These limits are designed to provide reasonable protection against harmful interference when the equipment is operated in a residential environment notwithstanding use in commercial, business and industrial environments. This equipment generates, uses, and can radiate radio frequency energy and, if not installed and used in accordance with the instruction manual, may cause harmful interference to radio communications.

The Base Station equipment has been tested and found to comply with the limits for a class A digital device, pursuant to part 15 of the FCC rules and to EN 301 489-1 rules. These limits are designed to provide reasonable protection against harmful interference when the equipment is operated in commercial, business

and industrial environments. This equipment generates, uses, and can radiate radio frequency energy and, if not installed and used in accordance with the instruction manual, may cause harmful interference to radio communications. Operation of this equipment in a residential area is likely to cause harmful interference in which case the user will be required to correct the interference at the user's own expense.

## FCC Radiation Hazard Warning

To comply with FCC RF exposure requirement, the antenna used for this transmitter must be fixed-mounted on outdoor permanent structures with a separation distance of at least 2 meter from al persons for antennas with a gain up to 28 dBi.

## Antenna Compliance Statement

This device has been designed to operate with the antennas listed in Table 1-3, and having a maximum gain of 28dbi. Antennas not included in this list or having a gain greater than 28dBi are strictly prohibited for use with this device. The required antenna impedance is 50 ohms.

To reduce potential radio interference to other users, the antenna type and its gain should be so chosen that the Equivalent Isotropically Radiated Power (EIRP) is not more than that permitted for successful communication.

## R&TTE Compliance Statement

This equipment complies with the appropriate essential requirements of Article 3 of the R&TTE Directive 1999/5/EC.

## Safety Considerations

For the following safety considerations, "Instrument" means the BreezeACCESS VL units' components and their cables.

## Caution

To avoid electrical shock, do not perform any servicing unless you are qualified to do so.

## Line Voltage

Before connecting this instrument to the power line, make sure that the voltage of the power source matches the requirements of the instrument.

## Radio

The instrument transmits radio energy during normal operation. To avoid possible harmful exposure to this energy, do not stand or work for extended periods of time in front of its antenna. The long-term characteristics or the possible physiological effects of Radio Frequency Electromagnetic fields have not been yet fully investigated.

## Outdoor Unit and Antenna Installation and Grounding

Ensure that outdoor units, antennas and supporting structures are properly installed to eliminate any physical hazard to either people or property. Make sure that the installation of the outdoor unit, antenna and cables is performed in accordance with all relevant national and local building and safety codes. Even where grounding is not mandatory according to applicable regulation and national codes, it is highly recommended to ensure that the outdoor unit and the antenna mast (when using external antenna) are grounded and suitable lightning protection devices are used so as to provide protection against voltage surges and static charges. In any event, Alvarion is not liable for any injury, damage or regulation violations associated with or caused by installation, grounding or lightning protection.

## Disposal of Electronic and Electrical Waste



### Disposal of Electronic and Electrical Waste

Pursuant to the WEEE EU Directive electronic and electrical waste must not be disposed of with unsorted waste. Please contact your local recycling authority for disposal of this product.



## Important Notice

This user manual is delivered subject to the following conditions and restrictions:

- This manual contains proprietary information belonging to Alvarion Ltd. Such information is supplied solely for the purpose of assisting properly authorized users of the respective Alvarion products.
- No part of its contents may be used for any other purpose, disclosed to any person or firm or reproduced by any means, electronic and mechanical, without the express prior written permission of Alvarion Ltd.
- The text and graphics are for the purpose of illustration and reference only. The specifications on which they are based are subject to change without notice.
- The software described in this document is furnished under a license. The software may be used or copied only in accordance with the terms of that license.
- Information in this document is subject to change without notice.
- Corporate and individual names and data used in examples herein are fictitious unless otherwise noted.
- Alvarion Ltd. reserves the right to alter the equipment specifications and descriptions in this publication without prior notice. No part of this publication shall be deemed to be part of any contract or warranty unless specifically incorporated by reference into such contract or warranty.
- The information contained herein is merely descriptive in nature, and does not constitute an offer for the sale of the product described herein.
- Any changes or modifications of equipment, including opening of the equipment not expressly approved by Alvarion Ltd. will void equipment warranty and any repair thereafter shall be charged for. It could also void the user's authority to operate the equipment.

Some of the equipment provided by Alvarion and specified in this manual, is manufactured and warranted by third parties. All such equipment must be installed and handled in full compliance with the instructions provided by such manufacturers as attached to this manual or provided thereafter by Alvarion or the manufacturers. Noncompliance with such instructions may result in serious damage and/or bodily harm and/or void the user's authority to operate the equipment and/or revoke the warranty provided by such manufacturer.





# About This Manual

This manual describes the BreezeACCESS VL Broadband Wireless Access System Release 5.1 and how to install, operate and manage the system components.

This manual is intended for technicians responsible for installing, setting up and operating the BreezeACCESS VL system, and for system administrators responsible for managing the system.

This manual contains the following chapters and appendices:

- **Chapter 1** – System description: Describes the BreezeAccess VL system and its components.
- **Chapter 2** – Installation: Describes how to install the system components.
- **Chapter 3** – Commissioning: Describes how to configure basic parameters, align the Subscriber Unit antenna and validate unit operation.
- **Chapter 4** – Operation and Administration: Describes how to use the BreezeACCESS VL Monitor application for configuring parameters, checking system status and monitoring performance.
- **Appendix A** – Software Version Loading Using TFTP: Describes how to load a new software version using TFTP.
- **Appendix B** – File Download and Upload Using TFTP: Describes how to download and upload configuration files using TFTP. This procedure is also applicable for uploading country code and feature license files.
- **Appendix C** – Using the Set Factory Defaults Utility: Describes how to use the Set Factory Defaults utility to enable management access to units where wrong or unknown configuration disables regular access to the unit for management purposes.
- **Appendix D** – Preparing the indoor to outdoor SU cable: Provides details on preparation of the indoor to outdoor Ethernet cable.
- **Appendix E** – Parameters Summary: Provides an at a glance summary of the configuration parameters, value ranges and default values.

■ **Appendix F** – Troubleshooting.



# Contents

Legal Rights.....	xiii
Important Notice .....	xix
Chapter 1 - System Description .....	1
<b>1.1 Introducing BreezeACCESS VL.....</b>	<b>2</b>
<b>1.2 Base Station Equipment.....</b>	<b>4</b>
1.2.1 Modular Base Station Equipment .....	4
1.2.2 Standalone “Micro-cell” Access Unit.....	6
<b>1.3 Subscriber Unit .....</b>	<b>8</b>
1.3.1 SU-A/E Subscriber Units .....	8
1.3.2 SU-I Subscriber Units .....	11
1.3.3 The SU-E-BS.....	11
<b>1.4 BreezeACCESS B&amp;B (4.9 GHz only) .....</b>	<b>12</b>
<b>1.5 Networking Equipment.....</b>	<b>13</b>
<b>1.6 Management Systems .....</b>	<b>14</b>
1.6.1 AlvariCRAFT™ .....	14
1.6.2 AlvariSTAR™ .....	14
<b>1.7 Specifications .....</b>	<b>17</b>
1.7.1 Radio .....	17
1.7.2 Data Communication .....	20
1.7.3 Configuration and Management .....	21
1.7.4 Standards Compliance, General.....	22

1.7.5	Physical and Electrical .....	23
1.7.6	Environmental .....	31
<b>Chapter 2 - Installation .....</b>		<b>33</b>
<b>2.1</b>	<b>Installation Requirements .....</b>	<b>34</b>
2.1.1	Packing List.....	34
2.1.2	Indoor-to-Outdoor Cables .....	38
<b>2.2</b>	<b>Equipment Positioning Guidelines.....</b>	<b>39</b>
<b>2.3</b>	<b>Installing the Outdoor Unit.....</b>	<b>41</b>
2.3.1	Pole Mounting the Outdoor Unit.....	41
2.3.2	Pole Mounting the New SU-A/E-ODU.....	43
2.3.3	Protecting ODU Connections .....	47
2.3.4	Connecting the Grounding and Antenna Cables .....	47
2.3.5	Connecting the Indoor-to-Outdoor Cable.....	49
<b>2.4</b>	<b>Installing the Universal IDU Indoor Unit .....</b>	<b>52</b>
2.4.1	RESET Button Functionality .....	53
<b>2.5</b>	<b>Installing the SU-I.....</b>	<b>54</b>
2.5.1	Installation Requirements .....	54
2.5.2	SU-I Connectors and LEDs.....	55
2.5.3	Installation Guidelines.....	56
2.5.4	Installing the SU-I.....	56
2.5.5	Installing the Detached Antenna .....	57
<b>2.6</b>	<b>Installing the Modular Base Station Equipment.....</b>	<b>63</b>
2.6.1	BS-SH Slot Assignment .....	63
2.6.2	BS-PS-AC Power Supply Module .....	64
2.6.3	BS-PS-DC Power Supply Module.....	65
2.6.4	BS-AU Network Interface Module .....	66
2.6.5	Installing the BS-SH Chassis and Modules.....	67

---

Chapter 3 - Commissioning .....	69
<b>3.1 Configuring Basic Parameters .....</b>	<b>70</b>
3.1.1 Initial Configuration .....	70
3.1.2 Country Code Selection .....	72
3.1.3 Transmit Power Compliance With Regulations .....	73
<b>3.2 Using the Optional Y-cable (New SU-A/E-ODU) .....</b>	<b>75</b>
<b>3.3 Aligning the Subscriber Unit Antenna .....</b>	<b>76</b>
<b>3.4 Configuring the Subscriber Unit's Maximum Modulation Level .....</b>	<b>78</b>
<b>3.5 Operation Verification .....</b>	<b>80</b>
3.5.1 Outdoor Unit Verification .....	80
3.5.2 Indoor Unit Verification .....	83
3.5.3 SU-I Unit Verification .....	84
3.5.4 Verifying the Ethernet Connection (Modular Base station) .....	86
3.5.5 Verifying the Indoor-to-Outdoor Connection (Modular Base Station) .....	86
3.5.6 Verifying Data Connectivity .....	86
Chapter 4 - Operation and Administration .....	87
<b>4.1 Working with the Monitor Program .....</b>	<b>88</b>
4.1.1 Accessing the Monitor Program Using Telnet .....	88
4.1.2 Common Operations .....	89
<b>4.2 Menus and Parameters .....</b>	<b>91</b>
4.2.1 Main Menu .....	91
4.2.2 Info Screens Menu .....	91
4.2.3 Unit Control Menu .....	96
4.2.4 Basic Configuration Menu .....	111
4.2.5 Site Survey Menu .....	113
4.2.6 Advanced Configuration Menu .....	128

Appendix A - Software Version Loading Using TFTP ..... 211

Appendix B - File Download and Upload Using TFTP ..... 215

Appendix C - Using the Set Factory Defaults Utility ..... 219

Appendix D - Preparing the Indoor to Outdoor SU Cable ..... 221

Appendix E - Parameters Summary ..... 225

**E.1 Parameters Summary ..... 226**

        E.1.1 Unit Control Parameters ..... 226

        E.1.2 IP Parameters ..... 227

        E.1.3 Air Interface Parameters ..... 227

        E.1.4 Network Management Parameters ..... 230

        E.1.5 Bridge Parameters ..... 230

        E.1.6 Performance Parameters ..... 232

        E.1.7 Service Parameters ..... 233

        E.1.8 Security Parameters ..... 234

Appendix F - Troubleshooting ..... 237

**F.1 Ethernet Port Connection Problems ..... 238**

**F.2 SU Association Problems ..... 239**

**F.3 Low Throughput Problems ..... 240**



# Figures

Figure 2-1: Threaded Holes/Grooves .....	42
Figure 2-2: 3" Pole Installation Using Special Clamps.....	42
Figure 2-3: Back View of the new SU-A-ODU .....	43
Figure 2-4: New SU-A-ODU Pole Installation Using the Special Clamp, Vertical Polarization .....	44
Figure 2-5: New SU-A-ODU Pole Installation Using the Special Clamp, Horizontal Polarization .....	45
Figure 2-6: New SU-A-ODU Pole Installation Using the Tilt Accessory, Vertical Polarization .....	46
Figure 2-7: Bottom Panel of the ODU (all ODUs except to new SU-A/E-ODU, shown without the sealing assembly).....	48
Figure 2-8: Bottom Panel of the New SU-A-ODU (without IDU COM Sealing Cap).....	48
Figure 2-9: Bottom Panel of the New SU-E-ODU-0.9 GHz (without the IDU COM Sealing Cap).....	48
Figure 2-10: The Waterproof Seal .....	49
Figure 2-11: Inserting the IDU COM Cable into the Sealing Cap .....	50
Figure 2-12: Connecting the IDU COM connector and inserting the Sealing Cap .....	50
Figure 2-13: IDU PS 1073 Front Panel.....	52
Figure 2-14: SU-I Panel .....	55
Figure 2-15: Wall Mounting the Antenna .....	59
Figure 2-16: Wall Mount with Rotation Capability.....	60
Figure 2-17: Window Mounting the Antenna .....	61
Figure 2-18: Window Mounting with Rotation Capability .....	62
Figure 2-19: BS-SH Chassis Slot Assignment.....	63
Figure 2-20: BS-PS-AC Front Panel.....	64
Figure 2-21: BS-PS-DC Front Panel.....	65
Figure 2-22: BS-AU Front Panel.....	66
Figure 3-1: Connecting the Y-cable .....	75

Figures

---

Figure 4-1: Main Menu (Administrator Level) .....89

Figure 4-2: Ethernet Connector Pin Assignments .....222



# Tables

Table 1-1: Frequency Bands.....	3
Table 1-2: Access Unit ODU Types .....	5
Table 1-3: AU Antennas.....	6
Table 1-4: Subscriber Unit ODU Types .....	9
Table 1-4: SU-A/E Subscriber Unit Types .....	10
Table 1-5: SU-I Subscriber Units .....	11
Table 1-7: Radio Specifications .....	17
Table 1-7: Data Communication .....	20
Table 1-8: Configuration and Management .....	21
Table 1-9: Standards Compliance, General.....	22
Table 1-11: Mechanical Specifications, SU-A/E Subscriber Unit.....	23
Table 1-12: Connectors, SU-A/E Subscriber Unit.....	24
Table 1-12: Electrical Specifications, SU-A/E Subscriber Unit.....	24
Table 1-13: Mechanical and Electrical Specifications, SU-I Subscriber Unit.....	25
Table 1-14: Connectors, SU-I Subscriber Unit .....	25
Table 1-16: Mechanical Specifications, Modular Base Station Equipment .....	26
Table 1-16: Connectors, Modular Base Station Equipment.....	27
Table 1-17: Electrical Specifications, Modular Base Station Equipment.....	27
Table 1-19: Mechanical Specifications, Stand Alone Access Unit .....	28
Table 1-19: Connectors, Stand Alone Access Unit.....	29
Table 1-20: Electrical Specifications, Stand Alone Access Unit .....	29
Table 1-21: 25dBi Antenna Specifications .....	30
Table 1-22: SU-I-D Wall/Window Detached Antenna Specifications.....	30
Table 1-23: Environmental Specifications.....	31

Table 2-1: Subscriber Unit ODU Types.....	34
Table 1-2: Access Unit ODU Types.....	36
Table 1-2: Access Unit ODU Types.....	37
Table 2-2: Approved Category 5E Ethernet Cables.....	38
Table 2-3: SU-I Panel Components.....	55
Table 2-4: BS-PS LED Functionality .....	64
Table 3-1: Basic Parameters .....	70
Table 3-2: Regulation Maximum EIRP .....	73
Table 3-3: Recommended Maximum Modulation Level*.....	79
Table 3-4: AU-ODU LEDs .....	80
Table 3-5: SU-ODU LEDs .....	81
Table 3-6: SU-ODU SNR Bar LED Functionality.....	82
Table 3-7: BS-AU LEDs.....	83
Table 3-8: PS1073 SU IDU / AU-SA IDU LEDs .....	84
Table 3-9: SU-I LEDs .....	85
Table 3-10: SU-I SNR Bar LED Functionality.....	86
Table 4-1: Default Passwords .....	88
Table 4-2: Parameters not changed after Set Complete Factory/Operator Defaults .....	99
Table 4-3: Parameters that are not changed after Set Partial Factory/Operator Defaults .....	99
Table 4-4: Authentication and Association Process .....	122
Table 4-5: VLAN Management Port Functionality .....	169
Table 4-6: VLAN Data Port Functionality - Access Link .....	170
Table 4-7: VLAN Data Port Functionality - Trunk Link .....	171
Table 4-8: VLAN Data Port Functionality - Hybrid Link .....	171
Table 4-9: VLAN Data Port Functionality for SU - Service Provider Link.....	172
Table 4-10: VLAN Data Port Functionality for AU - Service Provider Link.....	173
Table 4-11: Recommended Maximum Modulation Level* .....	186
Table 4-12: MIR Ranges and Defaults .....	195
Table 4-13: CIR Ranges and Defaults.....	196





---

# Chapter 1 - System Description

## In This Chapter:

- [Introducing BreezeACCESS VL](#), page 2
- [Base Station Equipment](#), page 4
- [Subscriber Unit](#), page 8
- [BreezeACCESS B&B \(4.9 GHz only\)](#), page 12
- [Networking Equipment](#), page 13
- [Management Systems](#), page 14
- [Specifications](#), page 17

## 1.1 Introducing BreezeACCESS VL

BreezeACCESS VL is a high capacity, IP services oriented Broadband Wireless Access system. The system employs wireless packet switched data technology to support high-speed IP services including fast Internet and Virtual Private Networks. BreezeACCESS VL users are provided with a network connection that is always on, supporting immediate access to the Internet and other IP services at high data rates. The system is designed for cellular-like deployment, enabling the system architecture to vary in size and structure. A system can include any number of cells, each containing several Access Units for better coverage of densely populated areas.

BreezeACCESS VL can support sensitive applications through authentication and/or data encryption utilizing WEP or AES algorithm with 128-bit keys. FIPS (Federal Information Processing Standards) 197 certified encryption algorithm is optionally available for Access Units with HW revision C and higher (except to AUS units). The system supports Virtual LANs based on IEEE 802.1Q, enabling secure operation and Virtual Private Network (VPN) services and enabling teleworkers or remote offices to conveniently access their enterprise network. The system supports layer-2 traffic prioritization based on IEEE 802.1p and layer-3 traffic prioritization based on either IP ToS Precedence (RFC791) or DSCP (RFC2474). It also supports traffic prioritization based on UDP and/or TCP port ranges. In addition, it may use the optional Wireless Link Prioritization (WLP) feature to fully support delay sensitive applications, enabling Multimedia Application Prioritization (MAP) for high performance voice and video. The implementation of MAP through the unique WLP protocol revolutionizes the business model by increasing, for example, the number of simultaneous VoIP calls per sector by as much as 500%.

BreezeACCESS VL products operate in unlicensed frequency bands in Time Division Duplex (TDD) mode, using Orthogonal Frequency Division Multiplexing (OFDM) modulation with Forward Error Correction (FEC) coding. Using the enhanced multi-path resistance capabilities of OFDM modem technology, BreezeACCESS VL enables operation in near and non-line-of-sight (NLOS) environments. These qualities enable service providers to reach a previously inaccessible and broader segment of the subscriber population.

BreezeACCESS VL is designed to enable construction of “mixed” cells, where it can be used together with other BreezeACCESS products using GFSK modulation, including BreezeACCESS II, BreezeACCESS MMDS, BreezeACCESS XL and BreezeACCESS V.

BreezeACCESS VL products are currently available in the following frequency bands:

<b>Band</b>	<b>Frequencies (MHz)</b>
4.9	4900 – 5100
5.2	5150 – 5350
5.3	5250 – 5350
5.4	5470 – 5725
5.8	5725 – 5875
0.9	902 - 925

The available frequencies, as well as other parameters, depend on applicable local regulations. The actual operating frequencies used by the system can be configured according to applicable radio regulations and specific deployment considerations.

A BreezeACCESS VL system comprises the following:

- **Customer Premise Equipment (CPE):** BreezeACCESS VL Subscriber Units (SUs).
- **Base Station Equipment (BS):** BreezeACCESS VL Access Units and supporting equipment.
- **Networking Equipment:** Standard Switches/Routers supporting connections to the backbone and/or Internet.
- **Management Systems:** SNMP-based Management, Billing and Customer Care, and other Operation Support Systems.

## 1.2 Base Station Equipment

The Access Units, installed at the Base Station site, provide all the functionality necessary to communicate with the Subscriber Units and to connect to the backbone of the Service Provider.

There are 2 lines of Access Units with different architectures:

- Modular Base Station Equipment
- Standalone “Micro-Cell” Access Unit

### 1.2.1 Modular Base Station Equipment

The Base Station Equipment is based on the BS-SH 3U chassis, which is suitable for installation in 19-inch racks. The chassis contains one or two Power Supply modules and has 8 slots that can accommodate BS-AU Network Interface modules. These slots can also

accommodate various combinations of other modules, including Network Interface (BS-AU) modules for Access Units operating in any of the bands supported by BreezeACCESS equipment



using GFSK modulation, including BreezeACCESS II, BreezeACCESS MMDS, BreezeACCESS XL and BreezeACCESS V. It can also accommodate a BS-GU GPS and Alarms module to support GPS-based synchronization of BreezeACCESS systems using Frequency Hopping radios.

Two different types of power supply modules are available for the BreezeACCESS VL modules: The BS-PS-DC that is powered from a -48 VDC power source, and the BS-PS-AC, powered from the 110/220 VAC mains. The optional use of two power supply modules ensures fail-safe operation through power supply redundancy. When the same chassis is used also for Access Unit modules belonging to other BreezeACCESS families using GFSK modulation, then one BS-PS power supply (AC or DC) should be used to provide power to the BreezeACCESS VL Access Units, and a different power supply module, suitable for GFSK equipment, is required for powering the BreezeACCESS GFSK Access Units.

Each BS-AU module and its outdoor radio unit (AU-ODU) comprise an AU-E-BS Access Unit that together with an external antenna serves a single sector. There are two types of Access Units, differing in the maximum number of Subscriber Units that they can serve:

- The AU-BS Access Unit can serve up to 512 Subscriber Units (124 when Data Encryption is used).
- The AUS-BS Access Unit can serve up to 8 SUs except SU-54 (refer to section 1.3 for details on availability of SU types in different bands). Optionally, it may be licensed to support also SU-54 units (in bands where SU-54 unit type is available. SU-54 is not available in the 0.9 GHz band).

**NOTE**

For convenience, all references to AU-BS are applicable also for AUS-BS, unless explicitly stated otherwise.

The AU-ODU outdoor unit contains the processing and radio modules and connects to an external antenna using a short RF cable.

There are two types of AU-ODUs:



**Table 1-2: Access Unit ODU Types**

AU ODU Type	Description
AU-E-ODU (all bands except 0.9 GHz)	A rectangular enclosure (30.5 x 11.7 x 5.7 cm) with a connection to an external antenna (not included). Not available in the 0.9 GHz band (HW revision D or lower).
New AU-E-ODU (0.9 GHz units only)	A diamond shaped enclosure (22 x 22 x 7 cm) with a connection to an external antenna (not included). The smaller size new AU-E-ODU (HW revision F) is currently available only in the 0.9 GHz band.

E model units are supplied without an antenna.

The available antennas are listed in Table 1-3:

<b>Antenna</b>	<b>Band (MHz)</b>	<b>Horizontal Beam Width</b>	<b>Gain (dBi)</b>
AU-Ant-5G-16-60	5150-5875	60°	16
AU-Ant-5G-17-90	5150-5875	90°	17
AU-Ant-5G-15-120	5150-5875	120°	15
AU-Ant-4.9G-15-120	4900-5100	120°	15
AU-Ant-4.9G-9-Omni	4900-5100	360°	9
AU-Ant-5.8G-8-Omni	5725-5875	360°	8
AU-Ant 5.8G-14-120-UK (The antenna pattern complies with Ofcom's IR 2007 EIRP profiles)	5725-5850	120°	14
AU-Ant-0.9G-V/H-10-90	902-928	90°	2x10
AU-Ant-0.9G-7-Omni	902-928	360°	7

The BS-AU indoor module connects to the network through a standard IEEE 802.3 Ethernet 10/100BaseT (RJ 45) interface. The indoor module is connected to the outdoor unit via a Category 5E Ethernet cable. This cable carries Ethernet traffic between the indoor module and the outdoor unit, and also transfers power (54 VDC) and control from the indoor module to the outdoor unit.

## 1.2.2 Standalone “Micro-cell” Access Unit

The standalone AU-E-SA Access Unit is very similar to the AU-E-BS unit. The difference is in the structure of the indoor part; in the AU-E-SA Access Unit the indoor unit is a standalone desktop or wall-mountable unit (the same Universal IDU that is also used in the SU) rather than a 19” module.

There are two types of Standalone Access Units, differing in the maximum number of Subscriber Units that they can serve:

- The AU-SA Access Unit can serve up to 512 Subscriber Units (124 when Data Encryption is used).
- The AUS-SA Access Unit can serve up to 8 SUs except SU-54 (refer to section 1.3 for details on availability of SU types in different bands). Optionally, it



may be licensed to support also SU-54 units (in bands where SU-54 unit type is available. SU-54 is not available in the 0.9 GHz band).

**NOTE**

For convenience, all references to AU-SA are applicable also for AUS-SA, unless explicitly stated otherwise.

The IDU connects to the network through a standard IEEE 802.3 Ethernet 10/100BaseT (RJ 45) interfaces and is powered from the 110/220 VAC mains. The indoor unit is connected to the outdoor unit via a Category 5 Ethernet cable. This cable carries Ethernet traffic between the indoor and the outdoor units, and also transfers power (54 VDC) and control from the indoor unit to the outdoor unit.

## 1.3 Subscriber Unit

The Subscriber Unit (SU) installed at the customer premises enables the customer data connection to the Access Unit. The Subscriber Unit provides an efficient platform for high speed Internet and Intranet services. The use of packet switching technology provides the user with a connection to the network that is always on, enabling immediate access to services.

There are two types of Subscriber Units:

- The SU-A/E series, where each unit comprises an Indoor Unit and an Outdoor Unit (with or without an integrated antenna). These products are intended for installation by a professional installer, enabling long-range connectivity.
- The SU-I series of all-indoor Subscriber Unit, intended for installation by non-professional end users in locations that are close to the Base Station.

In addition, there is a special variant of a Subscriber Unit, the SU-E-BS, where the indoor unit is designed for installation in the Base Station chassis. The SU-E-BS is intended primarily for backhauling or similar applications.

The following sections provide additional details on the various types of Subscriber Units.

### 1.3.1 SU-A/E Subscriber Units

The SU-A/E Subscriber Unit comprises a desktop or wall-mountable Indoor Unit (IDU) and an outdoor unit that contains the processing and radio modules. Several ODU types are available to support a wide range of requirements, as detailed in Table 1-4:

<b>SU ODU Type</b>	<b>Description</b>
SU-A-ODU	A rectangular enclosure plus a diamond shaped vertically polarized high-gain flat antenna integrated on the front panel (41.5 x 36.9 x 6.3 cm). Not available in the 0.9 GHz band. HW revision D or lower.
New SU-A-ODU	A diamond shaped enclosure (22 x 22 x 7 cm) with a vertically/horizontally polarized high-gain flat antenna integrated on the front panel.  The smaller size new SU-A-ODU (HW revision E) is currently available only in the 5.4 GHz and 5.8 GHz bands.
SU-E-ODU	A rectangular enclosure (30.5 x 11.7 x 5.7 cm) with a connection to an external antenna (not included). Not available in the 0.9 GHz band. HW revision D or lower.
New SU-E-ODU	A diamond shaped enclosure (22 x 22 x 7 cm) with a connection to an external antenna (not included).  The smaller size new AU-E-ODU (HW revision F) is currently available only in the 0.9 GHz band.

**SU-A-ODU and IDU****New SU-A-ODU**

For each ODU type, several models are available to support various end-users needs and applications, as detailed in Table 1-5:

<b>SU Type</b>	<b>Description</b>
SU-54-BD (SU-54)	A high-rate CPE that supports a full LAN. Not available in the 900 MHz band.
SU-6-BD (SU-6)	A medium rate CPE that supports a full LAN*. Not available in the 900 MHz band.
SU-3-BD (SU-3)	An entry level CPE that supports a full LAN**
SU-8-BD (SU-8)	A medium rate CPE that supports a full LAN. Available only in the 900 MHz band. The SU-8 functionality is available by loading the relevant feature license to an SU-3 unit.

\* In the past, SU-6-1D units were also available. After being upgraded to version 5.0, SU-6-1D units will automatically be changed to SU-6-BD units.

\*\* In the past, only SU-3-1D and SU-3-4D were available. After being upgraded to version 5.0, SU-3-1D/4D units will automatically be changed to SU-3-BD units. (In SNMP, these units will be reported as SU-3-4D. However, all SU-3 units running SW version 5.0 or higher will behave as SU-3-BD units, supporting a full LAN).

The IDU provides the interface to the user's equipment and is powered from the 110/220 VAC mains. The customer's data equipment is connected via a standard IEEE 802.3 Ethernet 10/100BaseT (RJ 45) interface. The indoor unit is connected to the outdoor unit via a Category 5 Ethernet cable. This cable carries Ethernet traffic between the indoor and the outdoor units, and also transfers power (54 VDC) and control from the indoor unit to the outdoor unit.

## 1.3.2 SU-I Subscriber Units

The SU-I is a compact Subscriber Unit intended for indoor installations by a non-professional user. The SU-I connects to a detached wall/window mountable antenna, and is available in the following configurations:



<b>SU-I Configuration</b>	<b>Description</b>
SU-I-D	All-indoor medium rate CPE supporting a full LAN, and a wall/window antenna kit
SU-I-E	All-indoor medium rate CPE supporting a full LAN (antenna not included)

The SU-I is currently available in the 5.4 GHz and 5.8 GHz bands.

### **NOTE**

It is recommended to pre-configure the units prior to shipment to end-users.



## 1.3.3 The SU-E-BS

The SU-E-BS is a special variant of a Subscriber Unit, where the indoor unit is designed for installation in the Base Station chassis. The outdoor unit is an SU-E-ODU, with a connection to an external antenna.

The SU-E-BS is intended primarily for backhauling or similar applications, including applications where it is used in conjunction with a GFSK-based system. The functionality of the LEDs of the module is the same as the LEDs of a regular AU-IDU module (with one minor exception-the W-LNK LED indicates whether the SU is associated with an AU).

## 1.4 BreezeACCESS B&B (4.9 GHz only)

BreezeACCESS B&B is available in the 4.9 GHz band to support point-to-point applications. A B&B point-to-point link includes:

- AU-D-SA-4.9-6-VL: A standalone AU with a 25 dBi, 6° high gain directional antenna.
- SU-D-4.9-54-BD-VL: SU-54-BD with a 25 dBi, 6° high gain directional antenna.

## 1.5 Networking Equipment

The Base Station equipment is connected to the backbone through standard data communication and telecommunication equipment. The 10/100BaseT ports of the AU modules can be connected directly to a multi-port router or to an Ethernet switch connected to a router.

The point-to-point link from the Base Station to the backbone can be either wired or wireless. Data to the Internet is routed to the backbone through standard routers.

## 1.6 Management Systems

The end-to-end IP-based architecture of the system enables full management of all components, from any point in the system. BreezeACCESS VL components can be managed using standard management tools through SNMP agents that implement standard and proprietary MIBs for remote setting of operational modes and parameters. The same SNMP management tools can also be used to manage other system components including switches, routers and transmission equipment. Security features incorporated in BreezeACCESS VL units restrict access for management purposes to specific IP addresses and/or directions, that is, from the Ethernet and/or wireless link.

In addition, the Ethernet WAN can be used to connect to other Operation Support Systems including servers, Customer Care systems and AAA (Authentication, Authorization and Admission) tools.

### 1.6.1 AlvariCRAFT™

AlvariCRAFT is an SNMP (Simple Network Management Protocol) application designed for on-line management of system components. This utility simplifies the installation and maintenance of small size installations by easily enabling the change of settings or firmware upgrade for one unit or an entire sector at a time.

AlvariCRAFT allows accessing a wide array of monitoring and configuration options, including:

- Device Manager for the selected Unit
- Selected unit or a complete sector configuration modification
- Firmware upgrade for a single unit or an entire sector
- On-line performance data monitoring
- Export of configuration details to a CSV file
- Support for Telnet cut-through to the managed devices and http cut-through to Gateways or Wi<sup>2</sup> APs behind connected SUs.

### 1.6.2 AlvariSTAR™

AlvariSTAR is a comprehensive Carrier-Class network management system for Alvarion's Broadband Wireless Access products-based Networks. AlvariSTAR is designed for today's most advanced Service Provider network Operation Centers

(NOCs), providing the network Operation, Administration and Maintenance (OA&M) staff and managers with all the network surveillance, monitoring and configuration capabilities that they require in order to effectively manage the BWA network while keeping the resources and expenses at a minimum.

AlvariSTAR is designed to offer the network's OA&M staff with a unified, scalable and distributable network management system. The AlvariSTAR system uses a distributed client-server architecture, which provides the service provider with a robust, scalable and fully redundant network management system in which all single points of failure can be avoided.

AlvariSTAR provides the following BWA network management functionality:

- Device Discovery
- Device Inventory
- Topology
- Fault Management
- Configuration Management
- Data Collection
- Performance Monitoring
- Device embedded Software Upgrade
- Security Management
- Northbound interface to other Network Management Systems.

Embedded with the entire knowledge base of BWA network operations, AlvariSTAR is a unique state-of-the-art power multiplier in the hands of the service provider that enables the provisioning of satisfied customers. AlvariSTAR dramatically extends the abilities of the service provider to provide a rich portfolio of services and to support rapid customer base expansion.

## 1.7 Specifications

### 1.7.1 Radio

<b>Item</b>	<b>Description</b>
Frequency <sup>1</sup>	<ul style="list-style-type: none"> <li>■ 0.9 GHz Family: 902 – 925 MHz</li> <li>■ 4.9 GHz Family: 4.900 – 5.100 GHz</li> <li>■ 5.2 GHz Family: 5.150 – 5.350 GHz</li> <li>■ 5.3 GHz Family: 5.250 – 5.350 GHz</li> <li>■ 5.4 GHz Family: 5.470 – 5.725 GHz</li> <li>■ 5.8 GHz Family: 5.725 – 5.875 GHz</li> </ul>
Operation Mode	Time Division Duplex (TDD)
Channel Bandwidth <sup>1</sup>	<ul style="list-style-type: none"> <li>■ 20 MHz</li> <li>■ 10 MHz (HW Revision C and higher)</li> <li>■ 10 MHz (0.9 GHz units only, HW Revision G AUs and HW Revision F SUs)</li> </ul>
Central Frequency Resolution	<ul style="list-style-type: none"> <li>■ 10 MHz for HW Revision A and B</li> <li>■ 5 MHz for HW Revision C and higher</li> <li>■ 1 MHz for 0.9 GHz units</li> </ul>
Antenna Port	<ul style="list-style-type: none"> <li>■ AU-ODU, SU-E-ODU: N-Type jack, 50 ohm</li> <li>■ SU-I: SMA jack, 50 ohm</li> </ul>
Max. Input Power (at antenna port)	<ul style="list-style-type: none"> <li>■ HW Revision A: -48 dBm typical</li> <li>■ HW Revision B and higher: -30 dBm typical</li> </ul>
Maximum Output Power <sup>2</sup>	All units except 0.9 GHz units: 21 dBm 0.9 GHz units: 27 dBm
SU-A-ODU Integral Antenna	21 dBi typical in the 5.150-5.875 GHz band, 20 dBi in the 4.9-5.1 GHz band. 10.5° AZ x 10.5° EL, vertical polarization, compliant with ETSI EN 302 326-3 V1.2.1 (2007-01)
New SU-A-ODU Integral Antenna (5.4/5.8 GHz)	20 +/- 1 dBi typical in the 5.250-5.875 GHz band, 14° AZ x 14° EL, vertical/horizontal polarization, compliant with ETSI EN 302 326-3 V1.2.1 (2007-01), RoHS

<b>Table 1-7: Radio Specifications</b>	
<b>Item</b>	<b>Description</b>
SU-I-D Detached Antenna	15 dBi typical net (excluding cable loss) in the 5.150-5.875 GHz band, 45°~55° horizontal x 10°~12° vertical, vertical polarization, RoHS compliant.
External Subscriber Antenna for SU-E 0.9 GHz	10.5 dBi minimum in the 902-928 MHz band. 55° AZ x 60° EL, vertical/horizontal polarization, RoHS compliant
AU Antennas (optional)	<ul style="list-style-type: none"> <li>■ AU-Ant-5G-16-60: 16 dBi typical, 5.150-5.875 GHz, 60° AZ x 10° EL sector antenna, vertical polarization, compliant with ETSI EN 302 326-3 V1.2.1 (2007-01)</li> <li>■ AU-Ant-5G-17-90: 17 dBi typical, 5.150-5.875 GHz, 90° AZ x 6° EL sector antenna, vertical polarization, compliant with ETSI EN 302 326-3 V1.2.1 (2007-01)</li> <li>■ AU-Ant-5G-15-120: 15 dBi typical, 5.150-5.875 GHz, 120° AZ x 6° EL sector antenna, vertical polarization, compliant with ETSI EN 302 326-3 V1.2.1 (2007-01)</li> <li>■ AU-Ant-4.9G-15-120: 15 dBi typical, 4.900-5.100 GHz, 124° AZ x 6.5° EL sector antenna, vertical polarization, compliant with ETSI EN 302 326-3 V1.2.1 (2007-01)</li> <li>■ AU-Ant-4.9G-9-Omni: 9 dB typical i, 4.900-5.100 GHz, 360° AZ x 8° EL, vertical polarization.</li> <li>■ AU-Ant-5.4G-8-Omni: 8 dBi typical, 5.150-5.725 GHz, 360° AZ x 4.5° EL, vertical polarization.</li> <li>■ AU-Ant-5.8G-8-Omni: 8 dBi typical, 5.725-5.875 GHz, 360° AZ x 9° EL, vertical polarization.</li> <li>■ AU-Ant-5.8G-14-120-UK: 14dBi typical, 5.725-5.850 GHz, 120° AZ x 6.5° EL sector antenna, vertical polarization. The antenna pattern complies with Ofcom's IR 2007 EIRP profiles.</li> <li>■ Ant-0.9G-V/H-10-90: 2x10dBi typical, 902-928 MHz, dual vertical/horizontal polarization, 90° AZ x 16° EL for Vpol, 90° AZ x 19° EL for Hpol.</li> <li>■ AU-Ant-0.9G-7-Omni: 7dBi typical, 902-928 MHz, 360° AZ x 17° EL, vertical polarization.</li> </ul>

<b>Item</b>	<b>Description</b>			
Sensitivity, Minimum (dBm at antenna port, PER<10%, 20 MHz bandwidth <sup>3</sup> )	Modulation Level <sup>4</sup>	Sensitivity (HW Rev. A)	Sensitivity (HW Rev. B and higher)	Minimum SNR
	1	-87 dBm	-89 dBm	6 dB
	2	-86 dBm	-88 dBm	7 dB
	3	-85 dBm	-86 dBm	9 dB
	4	-83 dBm	-84 dBm	11 dB
	5	-80 dBm	-81 dBm	14 dB
	6	-76 dBm	-77 dBm	18 dB
	7	-71 dBm	-73 dBm	22 dB
	8 <sup>5</sup>	-69 dBm	-71 dBm	23 dB
Modulation	OFDM modulation, 64 FFT points; BPSK, QPSK, QAM16, QAM64			

<sup>1</sup> The actual available frequency channels and bandwidth are defined by the selected Sub-Band, which reflects the applicable regulatory constraints. For more details refer to section [4.2.2.4](#).

<sup>2</sup> The actual maximum available output power for each modulation level is defined by the selected Sub-Band, which reflects the applicable regulatory constraints. For some countries the power may also be limited by limitations on the maximum EIRP (also included in the Sub-Band parameters) and the Antenna Gain parameter. For more details refer to section [4.2.2.4](#) and to section [4.2.6.2.8.1](#). For information on specific HW and Country Code limitations, see the Country Codes document.

<sup>3</sup> The sensitivity values are for a bandwidth of 20 MHz. When using a 10 MHz bandwidth, the sensitivity for each modulation level is 3 dB lower. For a 5 MHz bandwidth (900 MHz band) the sensitivity for each modulation level is 6 dB lower.

<sup>4</sup> Modulation Level indicates the radio transmission rate and the modulation scheme. Modulation Level 1 is for the lowest radio rate and modulation scheme.

<sup>5</sup> Modulation Level 8 is supported only in units with HW Revision B and above.

## 1.7.2 Data Communication

<b>Item</b>	<b>Description</b>
Standard compliance	IEEE 802.3 CSMA/CD
VLAN Support	Based on IEEE 802.1Q
Layer-2 Traffic Prioritization	Based on IEEE 802.1p
Layer-3 Traffic Prioritization	<ul style="list-style-type: none"><li>■ IP Precedence ToS (RFC791)</li><li>■ DSCP (RFC2474)</li></ul>
Layer 4 Traffic Prioritization	UDP/TCP destination ports

### 1.7.3 Configuration and Management

<b>Table 1-9: Configuration and Management</b>	
<b>Item</b>	<b>Description</b>
Management	<ul style="list-style-type: none"> <li>■ Monitor program via Telnet</li> <li>■ SNMP</li> <li>■ Configuration upload/download</li> </ul>
Management Access	From Wired LAN, Wireless Link
Management access protection	<ul style="list-style-type: none"> <li>■ Multilevel password</li> <li>■ Configuration of remote access direction (from Ethernet only, from wireless link only or from both)</li> <li>■ Configuration of IP addresses of authorized stations</li> </ul>
Security	<ul style="list-style-type: none"> <li>■ Authentication messages encryption option</li> <li>■ Data encryption option</li> <li>■ WEP and AES OCB 128-bit encryption algorithms</li> <li>■ FIPS 197 certified encryption (optional for Access Units with HW revision C or higher (excluding AUS units), under license)</li> <li>■ ESSID</li> </ul>
SNMP Agents	SNMP ver 1 client MIB II, Bridge MIB, Private BreezeACCESS VL MIB
Allocation of IP parameters	Configurable or automatic (DHCP client)
Software upgrade	<ul style="list-style-type: none"> <li>■ FTP</li> <li>■ TFTP</li> </ul>
Configuration upload/download	<ul style="list-style-type: none"> <li>■ FTP</li> <li>■ TFTP</li> </ul>

## 1.7.4 Standards Compliance, General

Table 1-10: Standards Compliance, General		
Type	Standard	
EMC	<ul style="list-style-type: none"> <li>■ FCC Part 15 class B</li> <li>■ ETSI EN 300 489-1</li> </ul>	
Safety	<ul style="list-style-type: none"> <li>■ UL 1950</li> <li>■ EN 60950</li> </ul>	
Environmental	Operation	<ul style="list-style-type: none"> <li>■ ETS 300 019 part 2-3 class 3.2E for indoor</li> <li>■ ETS 300 019 part 2-4 class 4.1E for outdoor</li> </ul>
	Storage	ETS 300 019-2-1 class 1.2E
	Transportation	ETS 300 019-2-2 class 2.3
Lightning protection (AU-ODU Antenna connection)	EN 61000-4-5, Class 3 (2kV)	
Radio	<ul style="list-style-type: none"> <li>■ FCC Part 15.247</li> <li>■ ETSI EN 300 328</li> <li>■ ETSI EN 301 893 (2003-04)</li> </ul>	

## 1.7.5 Physical and Electrical

### 1.7.5.1 SU-A/E Subscriber Unit

**NOTE**

In the 5.4 and 5.8 GHz band, the equipment may be shipped with a new, smaller size SU-A-ODU that supports both horizontal and vertical polarization.

#### 1.7.5.1.1 Mechanical

<b>Table 1-11: Mechanical Specifications, SU-A/E Subscriber Unit</b>			
<b>Unit</b>	<b>Structure</b>	<b>Dimensions (cm)</b>	<b>Weight (kg)</b>
General	An IDU indoor unit and an ODU outdoor unit with an integral antenna or a connection to an external antenna		
IDU PS1073	Plastic box (black), desktop or wall mountable	14 x 6.6 x 3.5	0.3
SU-A-ODU	Metal box plus an integral cut diamond shaped antenna in a plastic enclosure, pole or wall mountable	41.5 x 36.9 x 6.3	2.3
New SU-A-ODU (5.4/5.8 GHz)	Diamond shaped metal box plus an integral antenna in a plastic enclosure, pole or wall mountable	22 x 22 x 7	1.3
SU-E-ODU	Metal box, pole or wall mountable	30.5 x 11.7 x 5.7	1.8
New SU-E-ODU (0.9 GHz)	Diamond shaped metal box plus a plastic enclosure, pole or wall mountable	22 x 22 x 7	1.3
SU-Ant-0.9G-10	Pole mountable, elevation adjustable	30.5 x 30.5 x 2.5	1.3

## 1.7.5.1.2 Connectors

<b>Unit</b>	<b>Connector</b>	<b>Description</b>
IDU	ETHERNET	10/100BaseT Ethernet (RJ-45) Cable connection to a PC: crossed Cable connection to a hub: straight
	RADIO	10/100BaseT Ethernet (RJ-45)
	AC IN	3 pin AC power plug
SU-A-ODU	INDOOR	10/100BaseT Ethernet (RJ-45), protected by a waterproof sealing assembly
New SU-A-ODU (5.4/5.8 GHz)	IDU COM	10/100BaseT Ethernet (RJ-45), protected by a sealing cap
SU-E-ODU	INDOOR	10/100BaseT Ethernet (RJ-45), protected by a waterproof sealing assembly
	ANT	N-Type jack, 50 ohm, lightning protected
New SU-E-ODU (0.9 GHz)	IDU COM	10/100BaseT Ethernet (RJ-45), protected by a sealing cap
	ANT	N-Type jack, 50 ohm, lightning protected

## 1.7.5.1.3 Electrical

<b>Unit</b>	<b>Details</b>
General	Power consumption: 25W
IDU	AC power input: 85-265 VAC, 50-60 Hz
ODU	54 VDC from the IDU over the indoor-outdoor Ethernet cable

## 1.7.5.2 SU-I Subscriber Unit

### 1.7.5.2.1 Mechanical and Electrical

<b>Item</b>	<b>Details</b>
Dimensions (cm)	11.8 (H) x 20 (L) x 3.1 (W)
Weight (g)	600
Power Consumption	15W maximum
DC Power Input (from Power Supply)	48 VDC
Mains Power Input (to Power Supply)	90-265 VAC, 47-63 Hz

### 1.7.5.2.2 Connectors

<b>Connector</b>	<b>Description</b>
ETHERNET	10/100BaseT Ethernet (RJ-45) Cable connection to a PC: straight Cable connection to a hub: crossed
POWER (48 VDC)	DC Power Plug
RF	SMA jack

## 1.7.5.3 Modular Base Station Equipment

### 1.7.5.3.1 Mechanical

<b>Table 1-16: Mechanical Specifications, Modular Base Station Equipment</b>			
<b>Unit</b>	<b>Structure</b>	<b>Dimensions (cm)</b>	<b>Weight (kg)</b>
BS-SH	19" rack (3U) or desktop	13 x 48.2 x 25.6	4.76
BS-PS-DC	DC power supply module	12.9 x 7.0 x 25.3	1.2
BS-PS-AC	AC power supply module	12.9 x 7.0 x 25.3	1.2
BS-AU	Indoor module of the AU-BS access unit	12.9 x 3.5 x 25.5	0.15
AU-E-ODU (except 0.9 GHz units)	pole or wall mountable	30.5 x 11.7 x 5.7	1.8
New AU-E-ODU (0.9 GHz units)	Diamond shaped metal box plus a plastic enclosure, pole or wall mountable	22 x 22 x 7	1.3
AU-Ant-5G-16-60	2"-3.5" pole mountable	43.6 x 25 x 1.0	2.2
AU-Ant-5G-17-90	2"-3.5" pole mountable	55 x 25 x 1.1	1.5
AU-Ant-5G-15-120	2"-3.5" pole mountable	53 x 26 x 1.1	2.5
AU-Ant-5.4G-8-Omni	2.5"-4.5" pole mountable	70cm high, 6cm base diameter	1.5
AU-Ant-5.8G-8-Omni	Surface or pole mountable	40cm high, 3.2cm base diameter	0.23
AU-Ant-4.9G-15-120	2"-4" pole mountable	55 x 25 x 1.7	1.5
AU-Ant-5.8G-14-120-UK	1"-4" pole mountable	55 x 7.5 x 5	1
AU-Ant-0.9G-V/H-10-90	1.75"-4" pole mountable, up to 15° mechanical tilt	122 x 34.3 x 20.3	15.4
AU-Ant-0.9G-7-Omni	Pole mountable	244 cm high, 3.3 cm base diameter	1.8

### 1.7.5.3.2 Connectors

Unit	Connector	Description
BS-AU	10/100 BaseT	10/100BaseT Ethernet (RJ-45) with 2 embedded LEDs. Cable connection to a PC: crossed Cable connection to a hub: straight
	RADIO	10/100BaseT Ethernet (RJ-45) with 2 embedded LEDs
AU-ODU	INDOOR	10/100BaseT Ethernet (RJ-45), protected by a waterproof sealing assembly
	ANT	N-Type jack, 50 ohm, lightning protected
BS-PS-AC	AC-IN	3-PIN AC power plug
BS-PS-DC	-48 VDC	3 pin DC D-Type 3 power pins plug Amphenol 717TWA3W3PHP2V4RRM6
Antenna	RF	N-Type jack (on a 1.5m cable in the Omni-8-5.8)

### 1.7.5.3.3 Electrical

Unit	Details
General	240W max. for a fully equipped chassis (1 PS, 6 AU)
BS-PS-AC	AC power input: 85-265 VAC, 47-65 Hz DC power output: 54 V; 3.3 V
BS-PS-DC	DC power input: -48 VDC nominal (-34 to -72), 10 A max DC power output: 54 V; 3.3 V
BS-AU	3.3 VDC, 54 VDC from the power supply module(s) via the back plane
AU-ODU	54 VDC from the BS-AU over the indoor-outdoor Ethernet cable
AU-E-BS (IDU+ODU)	Power consumption: 30W

## 1.7.5.4 Standalone Access Unit

### 1.7.5.4.1 Mechanical

<b>Unit</b>	<b>Structure</b>	<b>Dimensions (cm)</b>	<b>Weight (kg)</b>
General	An IDU indoor unit and an AU-ODU outdoor unit connected to a detached antenna		
IDU PS1073	Plastic box (black), desktop or wall mountable	14 x 6.6 x 3.5	0.3
AU-E-ODU (except 0.9 GHz units)	pole or wall mountable	30.5 x 11.7 x 5.7	1.8
New AU-E-ODU (0.9 GHz units)	Diamond shaped metal box plus a plastic enclosure, pole or wall mountable	22 x 22 x 7	1.3
AU-Ant-5G-16-60	2"-3.5" pole mountable	43.6 x 25 x 1.0	2.2
AU-Ant-5G-17-90	2"-3.5" pole mountable	55 x 25 x 1.1	1.5
AU-Ant-5G-15-120	2"-3.5" pole mountable	53 x 26 x 1.1	2.5
AU-Ant-5.4G-8-Omni	2.5"-4.5" pole mountable	70 cm high, 6 cm base diameter	1.5
AU-Ant-5.8G-8-Omni	Surface or pole mountable	40 cm high, 3.2 cm base diameter	0.23
AU-Ant-4.9G-15-120	2"-4" pole mountable	55 x 25 x 1.7	1.5
AU-Ant-4.9G-9-Omni	1.5"-3" pole mountable	46 cm high, 5.5 cm base diameter	0.6
AU-Ant-5.8G-14-120-UK	1"-4" pole mountable	55 x 7.5 x 5	1
AU-Ant-0.9G-V/H-10-90	1.75"-4" pole mountable, up to 15° mechanical tilt	122 x 34.3 x 20.3	15.4
AU-Ant-0.9G-7-Omni	Pole mountable	244 cm high, 3.3 cm base diameter	1.8

### 1.7.5.4.2 Connectors

<b>Unit</b>	<b>Connector</b>	<b>Description</b>
IDU	ETHERNET	10/100BaseT Ethernet (RJ-45) Cable connection to a PC: crossed Cable connection to a hub: straight
	RADIO	10/100BaseT Ethernet (RJ-45)
	AC IN	3-PIN AC power plug
AU-ODU	INDOOR	10/100BaseT Ethernet (RJ-45), protected by a waterproof sealing assembly
	ANT	N-Type jack, 50 ohm, lightning protected
Antenna	RF	N-Type jack (on a 1.5m cable in the Omni-8-5.8)

### 1.7.5.4.3 Electrical

<b>Unit</b>	<b>Details</b>
General	Power consumption: 25W
IDU	AC power input: 85-265 VAC, 50-60 Hz
AU-ODU	54 VDC from the IDU over the indoor-outdoor Ethernet cable

### 1.7.5.5 25dBi Antenna (for B&B point-to-point link)

Table 1-22: 25dBi Antenna Specifications	
Item	Description
Regulatory Compliance	ETSI EN 302 085 V1.1.2 (2001-02) Range1
Frequency Range	4.900-5.100 GHz
Gain	25dBi min.
Azimuth Beamwidth	6°
Elevation Beamwidth	6°
Polarization	Linear (Vertical/Horizontal)
Dimensions (cm)	45 x 45 x 3
Weight (kg)	3 (max, excluding mounting kit)
Connector	N-Type, Female
Mounting Kit	2.75"-3.5" pole, 0 to -10° tilt, 2.2kg

### 1.7.5.6 SU-I-D Wall/Window Detached Antenna

Table 1-23: SU-I-D Wall/Window Detached Antenna Specifications	
Item	Description
Frequency Range	5.150-5.875 GHz
Gain	15dBi net (excluding cable loss).
Azimuth Beamwidth	45°~55°
Elevation Beamwidth	10°~12°
Polarization	Linear (Vertical)
Dimensions (cm)	33 x 9.3 x 2.1
Weight (g)	190
Connector	SMA jack
Cable	2 meter, 2 x SMA plug, 3.6 dB max insertion loss

## 1.7.6 Environmental

<b>Type</b>	<b>Unit</b>	<b>Details</b>
Operating temperature	Outdoor units	-40 °C to 55 °C
	Indoor equipment	0 °C to 40 °C
Operating humidity	Outdoor units	5%-95% non condensing, weather protected
	Indoor equipment	5%-95% non condensing



---

## Chapter 2 - Installation

### In This Chapter:

- [Installation Requirements](#), page 34
- [Equipment Positioning Guidelines](#), page 39
- [Installing the Outdoor Unit](#), page 41
- [Installing the Universal IDU Indoor Unit](#), page 52
- [Installing the SU-I](#), page 54

## 2.1 Installation Requirements

This section describes all the supplies required to install the BreezeACCESS VL system components and the items included in each installation package.



### NOTE

Installation requirements for SU-I are provided in section 2.5 on page 54.

### 2.1.1 Packing List

#### 2.1.1.1 SU-A/E Subscriber Unit

The SU-A/E installation kit includes the following components:

- IDU indoor unit with a wall mounting kit
- Mains power cord
- Any of the following Outdoor Units:

<b>SU ODU Type</b>	<b>Description</b>
SU-A-ODU	A rectangular enclosure plus a diamond shaped vertically polarized high-gain flat antenna integrated on the front panel (41.5 x 36.9 x 6.3 cm). Not available in the 0.9 GHz band. HW revision D or lower.
New SU-A-ODU	A diamond shaped enclosure (22 x 22 x 7 cm) with a vertically/horizontally polarized high-gain flat antenna integrated on the front panel.  The smaller size new SU-A-ODU (HW revision E) is currently available only in the 5.4 GHz and 5.8 GHz bands.
SU-E-ODU	A rectangular enclosure (30.5 x 11.7 x 5.7 cm) with a connection to an external antenna (not included). Not available in the 0.9 GHz band (HW revision D or lower).
New SU-E-ODU	A diamond shaped enclosure (22 x 22 x 7 cm) with a connection to an external antenna (not included).  The smaller size new AU-E-ODU (HW revision F) is currently available only in the 0.9 GHz band.

**NOTE**

The SU-A-ODU and SU-E-ODU are supplied without the waterproof sealing assembly for the INDOOR connector. The sealing assembly is supplied with the IDU to ODU cable kit.

- Pole mounting kit for the ODU (the kit for the new, smaller-size ODU is different from the kit for all other ODUs)
- An IDU to ODU cable kit, including 20m Category 5E Ethernet cable with a shielded RJ-45 connector crimped on one end, a waterproof sealing assembly and two shielded RJ-45 connectors (not applicable for the new smaller size SU-A-ODU and SU-E-ODU).

## 2.1.1.2 Modular Base Station Equipment

This section describes the items included in the installation packages for each Modular Base Station system component.

### 2.1.1.2.1 BS-SH Base Station Chassis

The BS-SH installation kit includes the following components:

- BS-SH chassis with blank panels
- Rubber legs for optional desktop installation

### 2.1.1.2.2 AU-E-BS Access Unit

The AU-E-BS and installation kit includes the following components:

- BS-AU Network Interface module
- AU-ODU outdoor unit:

<b>AU ODU Type</b>	<b>Description</b>
AU-E-ODU (all bands except 0.9 GHz)	A rectangular enclosure (30.5 x 11.7 x 5.7 cm) with a connection to an external antenna (not included). Not available in the 0.9 GHz band. HW revision D or lower.
New AU-E-ODU (0.9 GHz units only)	A diamond shaped enclosure (22 x 22 x 7 cm) with a connection to an external antenna (not included). The smaller size new AU-E-ODU (HW revision F) is currently available only in the 0.9 GHz band.

- Pole mounting kit for the AU-ODU (the kit for the new, smaller-size ODU is different from the kit for all other ODUs)
- RF cable

#### 2.1.1.2.3 BS-PS-AC Power Supply

Up to two BS-PS-AC power supply modules can be included in each Base Station chassis. The BS-PS-AC installation kit includes the following components:

- BS-PS-AC power supply module
- Mains power cord

#### 2.1.1.2.4 BS-PS-DC Power Supply

Up to two BS-PS-DC power supply modules can be included in each Base Station chassis. The BS-PS-DC installation kit includes the following components:

- BS-PS-DC power supply module
- DC power cable

### 2.1.1.3 AU-E-SA Standalone Access Unit

The AU-E-SA installation kit includes the following components:

- IDU indoor unit with a wall mounting kit
- Mains power cord
- AU-ODU outdoor unit:

<b>AU ODU Type</b>	<b>Description</b>
AU-E-ODU (all bands except 0.9 GHz)	A rectangular enclosure (30.5 x 11.7 x 5.7 cm) with a connection to an external antenna (not included). Not available in the 0.9 GHz band. HW revision D or lower.
New AU-E-ODU (0.9 GHz units only)	A diamond shaped enclosure (22 x 22 x 7 cm) with a connection to an external antenna (not included). The smaller size new AU-E-ODU (HW revision F) is currently available only in the 0.9 GHz band.

- Pole mounting kit for the AU-ODU (the kit for the new, smaller-size ODU is different from the kit for all other ODUs)
- RF cable

#### **2.1.1.4 Optional Items Available from Alvarion**

- IDU to ODU Category 5 Ethernet cable with a shielded RJ-45 connector crimped on one end and two shielded RJ-45 connectors (available in different lengths. For more details refer to section [2.1.2](#))
- Tilt Pole Mounting kit for the new, smaller size ODU.
- A Y-cable for connecting directly to the IDU COM of ODUs with a new (smaller size) enclosure for configuration/performance monitoring using a portable PC.

#### **2.1.1.5 Additional Installation Requirements**

The following items are also required to install the BreezeACCESS VL system components:

- Ethernet cable (straight for connecting to a hub/switch etc., crossed for connecting directly to a PC's NIC)
- Crimping tool for RJ-45 connectors
- Antenna, for E model units supplied without an antenna
- Ground cables with an appropriate termination

- Mains plug adapter or termination plug (if the power plug on the supplied AC power cord does not fit local power outlets)
- Portable PC with Ethernet card and Telnet software or AlvariCRAFT for BreezeACCESS VL\* application and a crossed Ethernet cable
- Installation tools and materials, including appropriate means (e.g. a pole) for installing the outdoor unit.

## 2.1.2 Indoor-to-Outdoor Cables



### NOTE

The length of the indoor-to-outdoor Ethernet cable should not exceed 90 meters. The length of the Ethernet cable connecting the indoor unit to the user's equipment, together with the length of the Indoor-to-Outdoor cable, should not exceed 100 meters.

Use only Category 5E Ethernet cables from approved manufacturers, listed in Table 2-4. Consult with Alvarion specialists on the suitability of other cables.

<b>Manufacturer</b>	<b>Part Number</b>
Synergy Cables Ltd. www.synergy-cables.com	612098
HES Cabling Systems www.hescs.com	H5E-00481
Teldor www.teldor.com	8393204101
Southbay Holdings Limited 11th Fl., 15, Lane 347, Jong Jeng Rd. Shin Juang City, Taipei County Taiwan, R.O.C Attn: Eva Lin Tel. 886-2-2832 3339 Fax. 886-2-2206 0081 E-mail: eva@south-bay.com.tw	TSM2404A0D

### NOTE



In case of missing information (product specifications, ordering information, etc.) regarding these products on the manufacturer's web site, it is highly recommended to contact the manufacturer's sales representative directly.

## 2.2 Equipment Positioning Guidelines

This section provides key guidelines for selecting the optimal installation locations for the various BreezeACCESS VL system components.



### CAUTION

ONLY experienced installation professionals who are familiar with local building and safety codes and, wherever applicable, are licensed by the appropriate government regulatory authorities should install outdoor units and antennas.

Failure to do so may void the BreezeACCESS VL product warranty and may expose the end user or Service Provider to legal and financial liabilities. Alvarion and its resellers or distributors are not liable for injury, damage or regulation violations associated with the installation of Outdoor Units or antennas.

Select the optimal locations for the equipment using the following guidelines:

- The outdoor unit can be either pole or wall mounted. Its location should enable easy access to the unit for installation and testing.
- The higher the placement of the antenna, the better the achievable link quality.
- AU-ODU units should be installed as close as possible to the antenna.
- The antenna connected to the AU-ODU unit, should be installed so as to provide coverage to all Subscriber Units (SUs) within its service area.



### NOTE

The recommended minimum distance between any two antennas serving adjacent sectors is 2 meters. The recommended minimum distance between two antennas serving opposite cells (installed back-to-back) is 5 meters.

- The antenna of the SU (integrated or external)) should be installed to provide a direct, or near line of sight with the Base Station antenna. The antenna should be aligned to face the Base Station.
- In some cases it might be necessary to up/down-tilt the antenna. An optional Tilt accessory for the ODU providing a tilt range of +/-15° is available from Alvarion. The tilt option might be necessary to either improve the link conditions or, if the SU is too close to the Base Station, to reduce the receive signals strength. As a rule of thumb, if the SU is located at a distance of less than 300 meters from the Base Station, it is recommended to up-tilt the antenna by approximately 10° to 15° (especially in line-of-sight conditions) to avoid saturation of the receivers by too strong signals.

- The indoor equipment should be installed as close as possible to the location where the indoor-to-outdoor cable enters the building. The location of the indoor equipment should take into account its connection to a power outlet and the customer's equipment.

## 2.3 Installing the Outdoor Unit

The following sections describe how to install the outdoor units, including pole mounting the ODU, and connecting the indoor-to-outdoor, grounding and RF cables.



### NOTE

Ensure that outdoor units, antennas and supporting structures are properly installed to eliminate any physical hazard to either people or property. Make sure that the installation of the outdoor unit, antenna and cables is performed in accordance with all relevant national and local building and safety codes. Even where grounding is not mandatory according to applicable regulation and national codes, it is highly recommended to ensure that the outdoor unit and the antenna pole (when using external antenna) are grounded and suitable lightning protection devices are used so as to provide protection against voltage surges and static charges. In any event, Alvarion is not liable for any injury, damage or regulation violations associated with or caused by installation, grounding or lightning protection.

### 2.3.1 Pole Mounting the Outdoor Unit



### NOTE

This section is not applicable for the new, smaller size ODUs. For details on pole mounting the new ODUs refer to section 2.3.2.

The Outdoor Unit can be mounted on a pole using one of the following options:

- Special clamps and threaded rods are supplied with each unit. There are two pairs of threaded holes on the back of the unit, enabling to use the special clamps for mounting the unit on diverse pole diameters.
- Special grooves on the sides of the unit enable the use of metal bands to secure the unit to a pole. The bands must be 9/16 inches wide and at least 12 inches long. The metal bands are not included with the installation package.



### NOTE

Be sure to mount the unit with the bottom panel, which includes the LED indicators, facing downward.

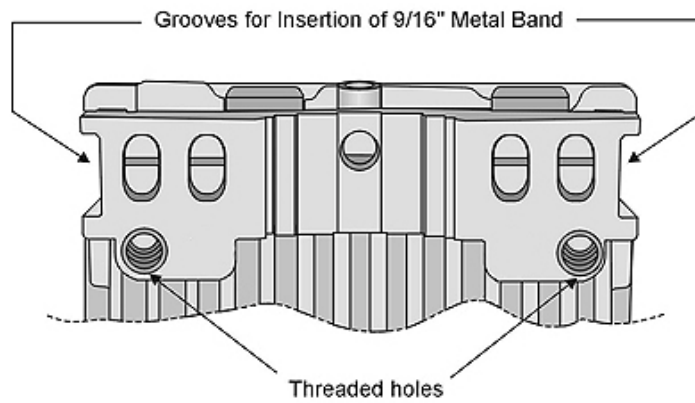

**Figure 2-1: Threaded Holes/Grooves**

Figure 2-2 illustrates the method of mounting an outdoor unit on a pole, using the clamps and threaded rods.

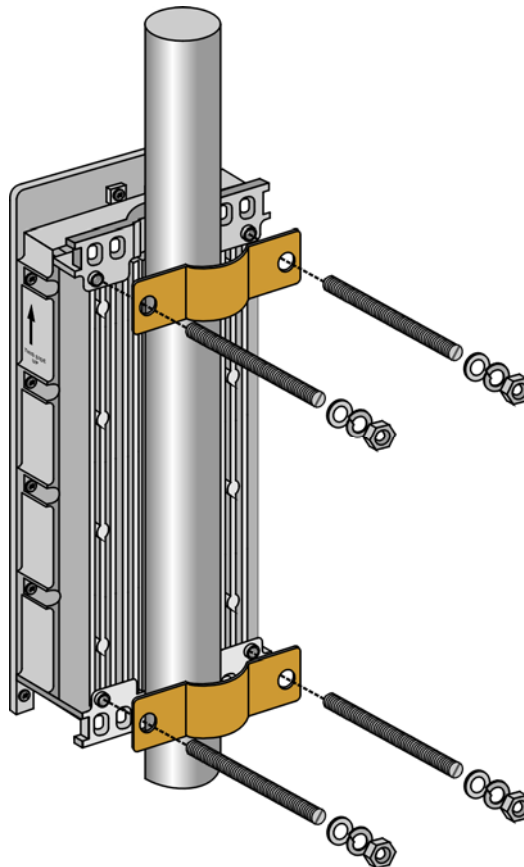

**Figure 2-2: 3" Pole Installation Using Special Clamps**

**NOTE**

There is a groove on one end of the threaded rod. Be sure to insert the threaded rods with the grooves pointing outward, as these grooves enable you to use a screwdriver to fasten the rods to the unit.



## 2.3.2 Pole Mounting the New ODU

The new ODU can be mounted on a 1" to 4" pole using one of the following options:

- A pole mounting kit is supplied with each unit. The kit includes a special clamp and a pair of threaded rods, flat washers, spring washers and nuts. There are two pairs of threaded holes on the back of the unit, enabling to use the mounting kit for installing the unit using either vertical or horizontal polarization. The clamp enables installing the unit on diverse pole diameters from 1" to 4".
- A Tilt Pole Mounting kit, providing a tilt range of  $\pm 15^\circ$  is available from Alvarion. The Tilt kit can be attached to the ODU and be mounted on a 1" to 4" pole using two 9/16" wide metal bands.

The following sections describe the installation of the SU-A-ODU. Installation of the new SU-E-ODU or AU-E-ODU (0.9 GHz) is similar, with the exception that it does not include an integral antenna and the polarization issue is not relevant.

### 2.3.2.1 Polarization

The new SU-A-ODU can be pole mounted to provide either vertical or horizontal polarization.

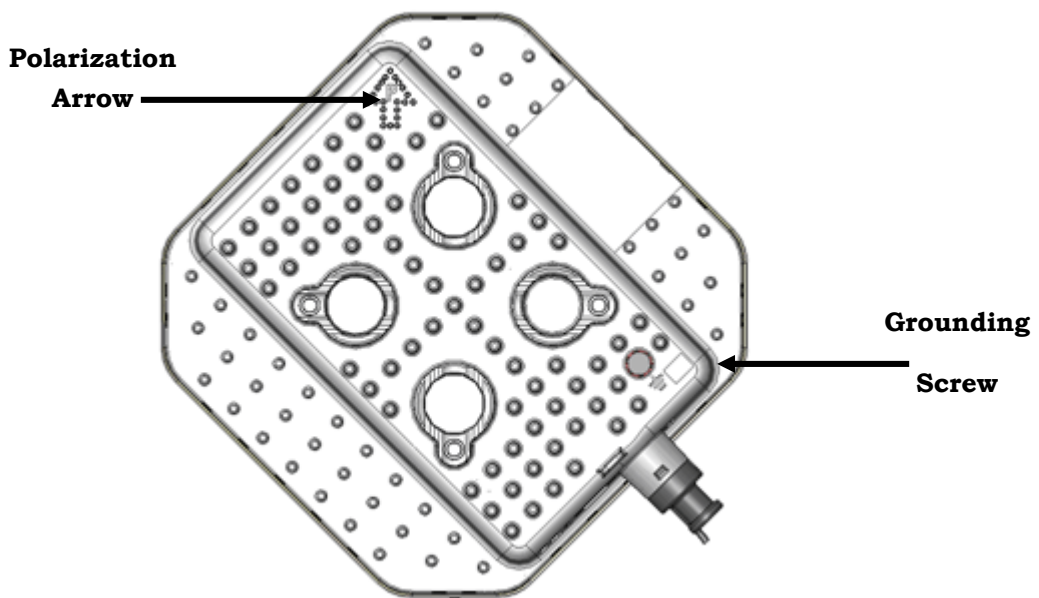

Figure 2-3: Back View of the new SU-A-ODU

The Polarization Arrow on the back of the unit indicates the type of polarization.

- For vertical polarization install the unit with the Polarization Arrow pointing upward (as in the figure above).
- For horizontal polarization install the unit with the Polarization Arrow pointing sideward and the connectors facing downward.

### 2.3.2.2 Pole Mounting the ODU Using the Clamp

Figure 2-4 and Figure 2-5 illustrate how to mount an ODU on a pole, using the clamp and threaded rods.

#### NOTE



There is a groove on one end of the threaded rod. Be sure to insert the threaded rods with the grooves pointing outward, and fasten them to the unit using a screwdriver. Install the unit with the bottom panel, which includes the connectors, facing downward.

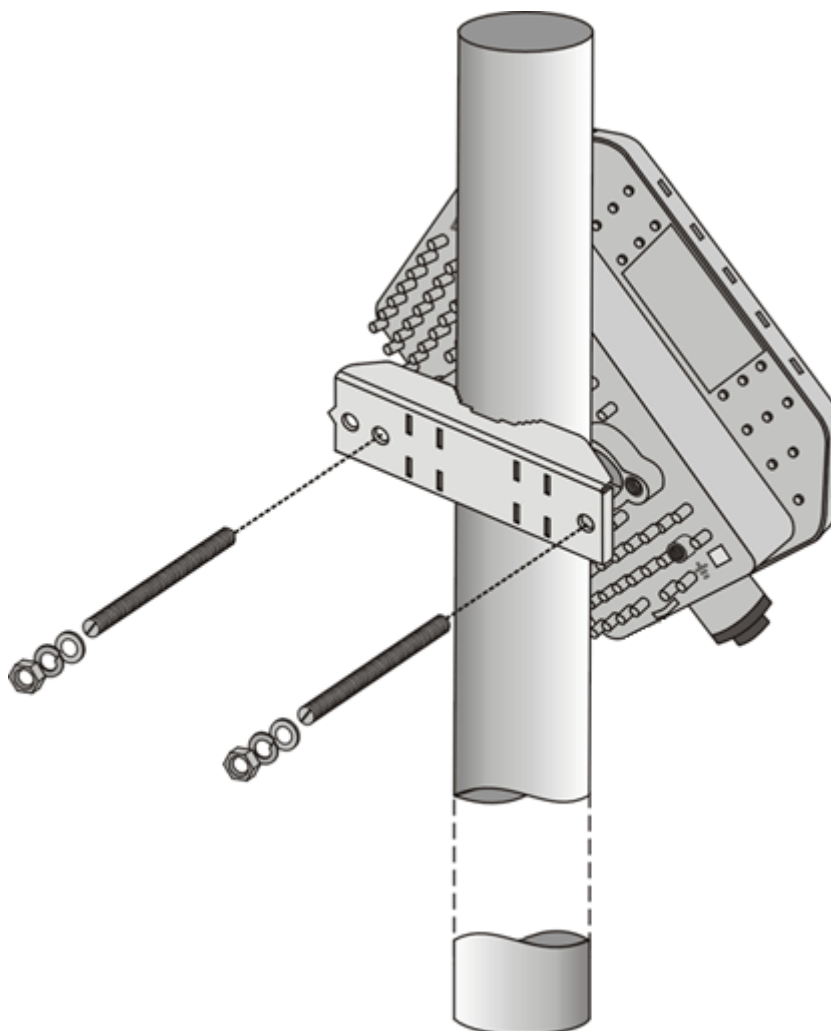
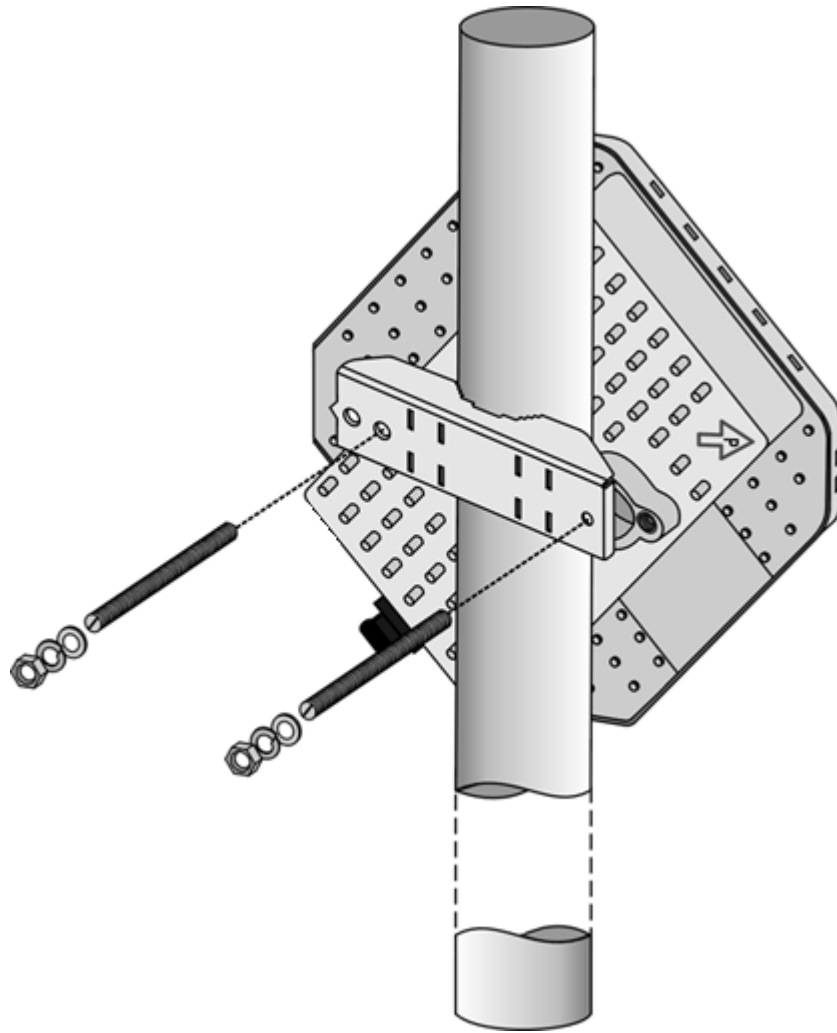
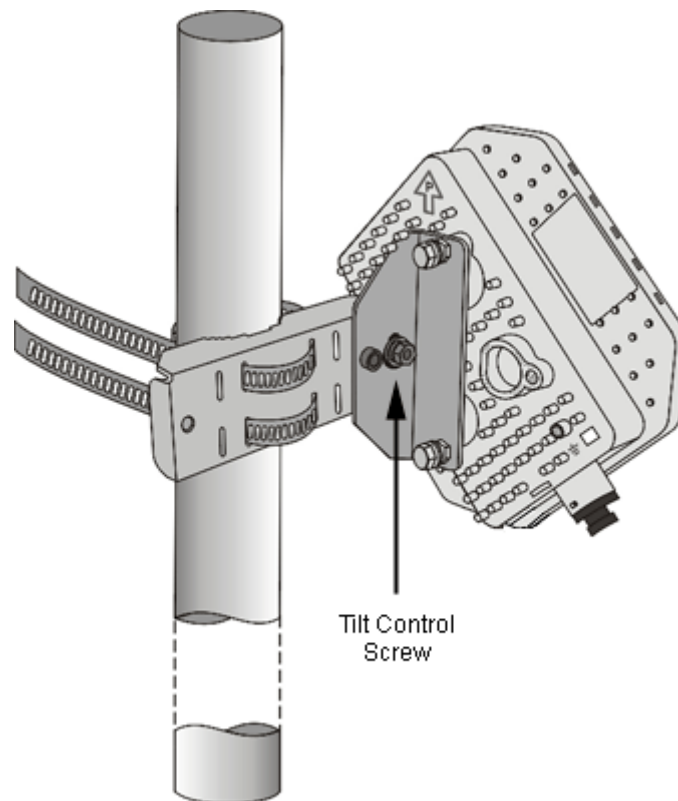

Figure 2-4: New SU-A-ODU Pole Installation Using the Special Clamp, Vertical Polarization



**Figure 2-5: New SU-A-ODU Pole Installation Using the Special Clamp, Horizontal Polarization**

### 2.3.2.3 Pole Mounting the ODU with the Tilt Accessory



**Figure 2-6: New SU-A-ODU Pole Installation Using the Tilt Accessory, Vertical Polarization**



**To mount the ODU on a pole using the Tilt accessory:**

- 1 Attach the Tilt accessory to the ODU using the two pairs of flat washers, spring washers and nuts supplied in the Tilt kit.
- 2 Mount the Tilt accessory on a 1" to 4" pole using two 9/16" metal bands.
- 3 Release slightly the Tilt Control Screw, tilt the ODU downward/upward as required, and re-tighten the screw.

## 2.3.3 Protecting ODU Connections

Use appropriate sealing material to protect the connection against moisture and humidity. Use removable sealing material, such as a tar seal, to enable future access to the connector.



### NOTE

Use high quality sealing material such as Scotch<sup>®</sup> 130C Linerless Rubber Splicing Tape from 3M to ensure IP-67 compliant protection against dust and water.

Loop & tie the cable near the unit for strain relief and for routing water away from the unit: use additional cable strips to route the cable such that water can accumulate on the cable bends, away from the unit.

## 2.3.4 Connecting the Grounding and Antenna Cables

The Grounding screw (marked  $\equiv$ ) is located on the bottom panel of the outdoor unit (in the new ODU it is located on the backside of the unit). The Antenna RF connector (marked  $\nabla$ ) is located on the top panel of the AU-E-ODU/SU-E-ODU (in the new 0.9 GHz AU-E-ODU it is located on the side).



### To connect the grounding cable:

- 1 Connect one end of a grounding cable to the grounding terminal and tighten the grounding screw firmly.
- 2 Connect the other end of the grounding cable to a good ground (earth) connection.



### To connect the RF cable (units with external antenna):

- 1 Connect one end of the coaxial RF cable to the RF connector on the unit.
- 2 Connect the other end of the RF cable to the antenna.
- 3 The RF connectors should be properly sealed to protect against rain and moisture.

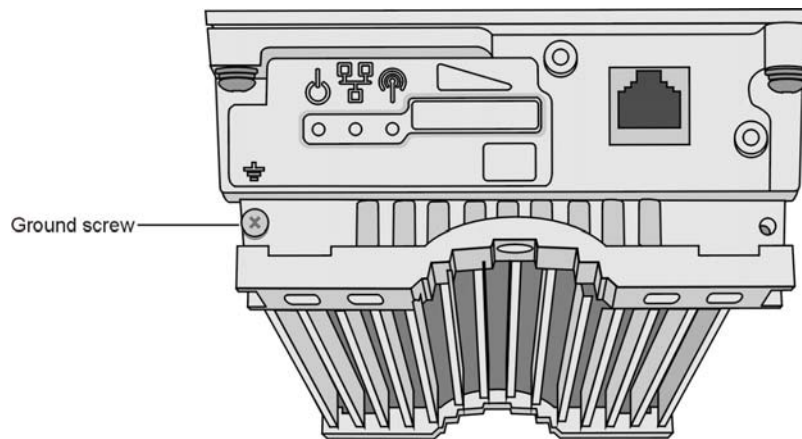

**Figure 2-7: Bottom Panel of the ODU**  
(all ODUs except to new ODU, shown without the sealing assembly)

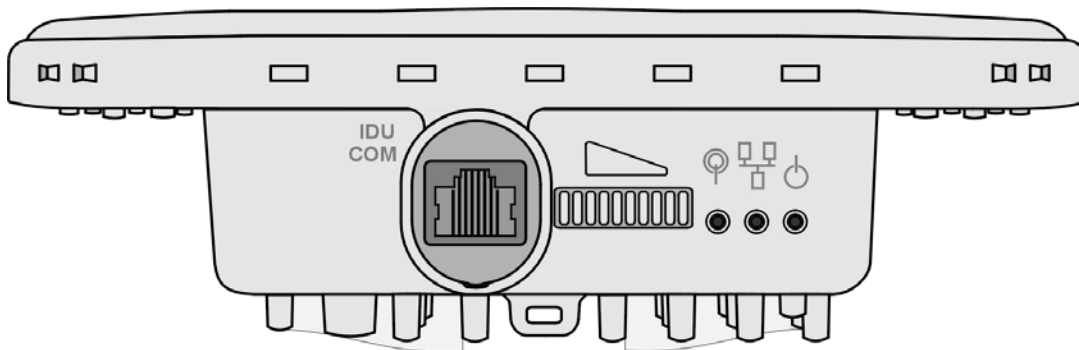

**Figure 2-8: Bottom Panel of the New SU-A-ODU (without IDU COM Sealing Cap)**

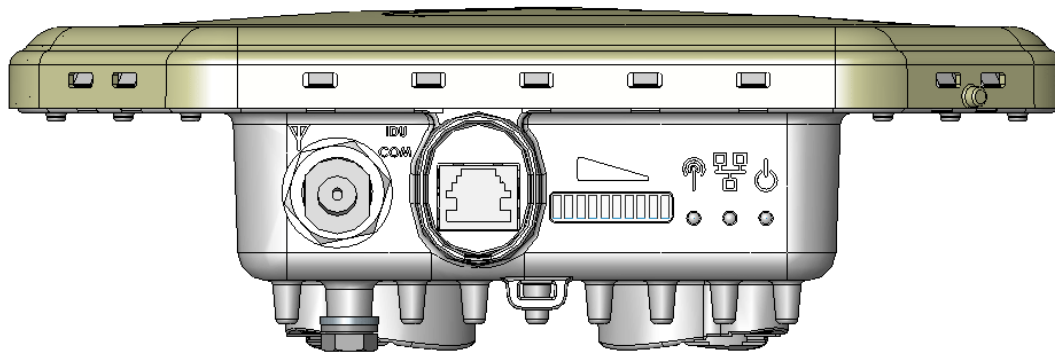

**Figure 2-9: Bottom Panel of the New 0.9 GHz ODU (without the IDU COM Sealing Cap)**

**NOTE**



The MAC Address of the unit is marked on both the ODU and the indoor unit (on the print side of the BS-AU module or on the bottom side of the Universal IDU). If for any reason the ODU is not used with the IDU with which it was shipped, the MAC Address of the system is in accordance with the marking on the ODU.

## 2.3.5 Connecting the Indoor-to-Outdoor Cable

### 2.3.5.1 Units with an Installed Waterproof Seal (not applicable to new ODU)



To connect the indoor-to-outdoor cable:

- 1 Remove the two screws holding the waterproof seal to the outdoor unit and remove the waterproof seal.
- 2 Unscrew the top nut from the waterproof seal.

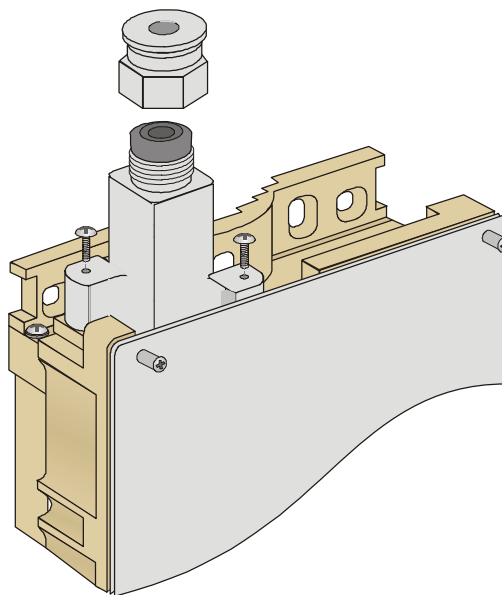

**Figure 2-10: The Waterproof Seal**

- 3 Route a straight Category 5E Ethernet cable (8-wire, 24 AWG) through both the top nut and the waterproof seal.

#### NOTE

Use only Category 5E 4x2x24# FTP outdoor cables from an approved manufacturer. See list of approved cables and length limitations in section [2.1.2](#).

- 4 Insert and crimp the RJ-45 connector. Refer to Appendix D for instructions on preparing the cable.
- 5 Connect the Ethernet cable to the outdoor unit RJ-45 connector.
- 6 Replace the waterproof seal and then the top nut. Make sure that the external jack of the cable is well inside the waterproof seal to guarantee a good seal.
- 7 Route the cable to the location selected for the indoor equipment.
- 8 Assemble an RJ-45 connector with a protective cover on the indoor end of the indoor-to-outdoor cable.

### 2.3.5.2 Units with a Waterproof Seal Supplied with the Ethernet Cable (not applicable to new ODU)



To connect the indoor-to-outdoor cable:

- 1 Verify that the o-ring supplied with the cable kit is in place.
- 2 Connect the RJ-45 connector of the Ethernet cable to the outdoor unit.
- 3 Attach the waterproof seal to the unit. Tighten the top nut.
- 4 Route the cable to the location selected for the indoor equipment.
- 5 Assemble an RJ-45 connector with a protective cover on the indoor end of the indoor-to-outdoor cable.  
See Appendix D for instructions on preparing the cable.

### 2.3.5.3 New ODU

- 1 The sealing cap has a special groove allowing to insert an ethernet cable with an already assembled RJ-45 connector through the cap. To expose the groove, lightly squeeze the cap. Carefully insert the cable with the assembled connector through the groove.

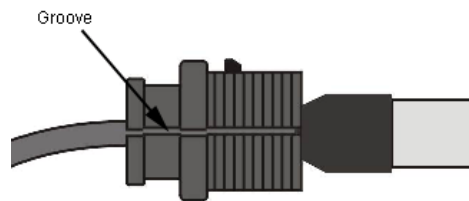

Figure 2-11: Inserting the IDU COM Cable into the Sealing Cap

- 2 Connect the Ethernet cable to the IDU COM RJ-45 connector.
- 3 Put the sealing cap back in its place. Make sure that the small protrusion on the side of the cap fits inside the hole on the connector's protective body.

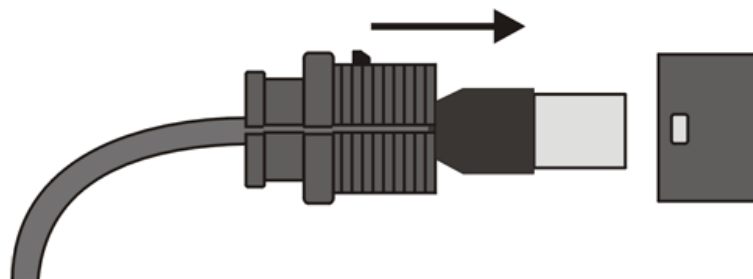

Figure 2-12: Connecting the IDU COM connector and inserting the Sealing Cap

- 4 Route the cable to the location selected for the indoor equipment.

- 5 Assemble a shielded RJ-45 connector with a protective cover on the indoor end of the IDU-ODU cable. See Appendix D for instructions on preparing the cable.

## 2.4 Installing the Universal IDU Indoor Unit

The unit can be placed on a desktop or a shelf. Alternatively, it may be wall-mounted using the kit supplied with the unit.

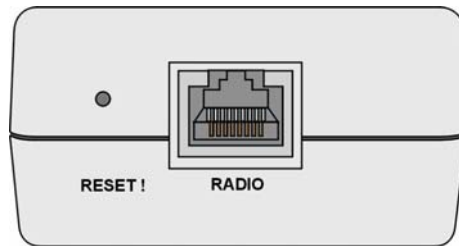

**Figure 2-13: IDU PS 1073 Front Panel**

The RADIO connector and RESET button are located on the front panel, the ETHERNET connector is located on the side panel and LEDs are located on the top panel.

### CAUTION



Do not connect the data equipment to the RADIO port. The RADIO port supplies DC power to the ODU, and this may harm other equipment connected to it.



### To install the IDU:

- 1 Connect the Indoor-to-Outdoor cable to the RADIO connector, located on the front panel of the indoor unit.
- 2 Connect the power cord to the unit's AC socket, located on the rear panel. Connect the other end of the power cord to the AC mains. The unit can operate with AC mains of 100-240 VAC, 50-60 Hz.

### NOTE



The color codes of the power cable are as follows:

Brown	Phase	~
Blue	Neutral	0
Yellow/Green	Ground	⊥

- 3 Verify that the POWER LED is lit, indicating that power is supplied to the unit.
- 4 Configure the basic parameters as described in section [3.1](#).
- 5 Connect the 10/100 BaseT ETHERNET connector to the network. The cable connection should be a straight Ethernet if connecting the indoor unit to a hub/switch and a crossed cable if connecting it directly to a PC Network Interface Card (NIC).

**NOTE**

The length of the Ethernet cable connecting the indoor unit to the user's equipment, together with the length of the Indoor-to-Outdoor cable, should not exceed 100 meters.

## 2.4.1 RESET Button Functionality

Using a sharp object, press the recessed RESET button for a short time to reset the unit and reboot from the Main version.

In units with ODU HW revision C and higher, the RESET button can be used for setting the unit to its factory defaults. Press the button for at least 5 seconds (until the ETH LED of the IDU stops blinking): the unit will reboot with the factory default configuration.

## 2.5 Installing the SU-I

The following sections describe how to install the SU-I CPE.

### 2.5.1 Installation Requirements

#### 2.5.1.1 Packing List

- SU-I CPE
- Power Adapter
- 3 meters Ethernet Cable
- Wall/window mountable detached antenna kit, including wall/window mounting accessories and a 2 meters SMA-SMA (M/M) RF cable (only with SU-I-D).

#### 2.5.1.2 Additional/Optional Items

- Mains plug adapter or termination plug (if the power plug on the power adapter not fit local power outlets. The Power Adapter is supplied with a North American power plug and an EU power connector adapter).
- Portable PC with an Ethernet card and a straight Ethernet cable for configuring parameters using either Telnet or AlvariCRAFT for BreezeACCESS VL application. TFTP server SW is required for downloading SW versions.
- Other installation tools and materials (means for securing cables to walls, etc.).

#### NOTE

Items marked with an asterisk (\*) are available from Alvarion.



## 2.5.2 SU-I Connectors and LEDs

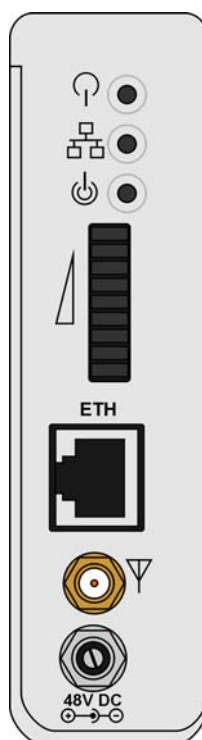





Figure 2-14: SU-I Panel

Table 2-5: SU-I Panel Components

Name		Description	Functionality
	Status	Self-test and power indication	Green: Power is available and self-test passed. Blinking Amber: Testing (not ready for operation) Red: Self-test failed. Fatal error
	Ethernet	Ethernet activity/ connectivity indication	Green: Ethernet link between the SU-I and the data equipment is detected, no activity Blinking Green: Ethernet connectivity is OK, with traffic on the port. Blinking rate proportional to traffic rate. Red: No Ethernet connectivity between the SU-I and the data equipment.
	W-Link	Wireless Link traffic Indication	Green: Unit is associated with an AU, no wireless link activity Blinking Green: Data received or transmitted on the wireless link. Blinking rate is proportional to traffic rate. Off: Wireless link disabled

Name		Description	Functionality
SNR bar		Received signal strength Indication	Red LED: Signal is too low (SNR < 4dB). 8 green LEDs: Quality of the received signal. Orange LED: Signal is too high (SNR > 50dB).
ETH		RJ-45 Connector	Connection to the user's LAN/PC: <ul style="list-style-type: none"> <li>■ Cable connection to a hub/switch/router: Crossed</li> <li>■ Cable connection to a PC: Straight</li> </ul>
	RF	SMA Jack	Connection to detached antenna
48V DC		DC Power Jack	Connection to Power Adapter

\* After power-up, the SIGNAL LEDs illuminates for a few seconds until self-test is finished.

## 2.5.3 Installation Guidelines

The unit can be placed on a desktop or a shelf. Instructions for the available installation options of the detached antenna (included in the SU-I-D package) are provided in the antenna package and in Section [2.5.5](#).

It is recommended to install the antenna on a window or on a wall according to specific conditions of the location. The antenna should be facing the direction of the Base Station. Use only the RF cable supplied with the antenna (if needed, use a longer Ethernet cable).

Avoid metal obstacles such as metal window frames or metal film anti-glare windows in the transmission path.

Position the antenna away from electrical equipment, including the data equipment, monitor etc., metal furniture, and moving metal objects such as metal fans or doors.

## 2.5.4 Installing the SU-I

### 2.5.4.1 Connecting the SU-I



#### To install the SU-I:

- 1 Connect the Power Adapter DC cable to the POWER jack. Connect the Power Adapter to the AC mains.
- 2 Verify that the green Status LED located on the unit's front panel illuminates, indicating that the power supply to the unit is OK and self test passed successfully.

- 3 Connect the RF cable supplied with the antenna to the SMA jack located on the unit's front panel. Install the antenna using the instructions provided in Section [2.5.5](#) on page 57, and connect to it the other end of the RF cable. Do not over-tighten the SMA connectors.
- 4 If parameters are not pre-configured, configure the basic parameters as described in Section 3.1.
- 5 Align the antenna as described in Section 3.3.
- 6 Connect the 10/100 Base-T Ethernet connector to the data equipment. The cable connection should be a crossed Ethernet if connecting to a hub/switch and a straight cable if connecting directly to a PC Network Interface Card (NIC).
- 7 Verify proper operation of the Ethernet link (see Table 2-5 for the Ethernet activity LED indication). To verify data connectivity from the end-user's PC or from a portable PC connected to the unit, ping a known device in the network, or try connecting to the Internet.

## 2.5.5 Installing the Detached Antenna

The detached antenna kit includes the following components:

- ALA04-200160 panel antenna
- 2 meter SMA-SMA (M/M) RF cable
- Simple wall mounting kit, enabling installation on a wall (without any capability for adjusting the direction). For installation instructions see Section [0](#).
- Wall mounting kit with rotation capability, enabling installation on a wall with capability for adjusting the direction. For installation instructions see Section [2.5.5.2](#).
- Simple window mounting accessories, enabling installation on a glass window (without any capability for adjusting the direction). For installation instructions see Section [2.5.5.3](#).
- Window mounting kit with rotation capability, enabling installation on a glass window (with rotation capability for adjusting the direction). For installation instructions see Section [2.5.5.4](#).



**NOTE**

Ensure that the antenna is mounted vertical to the floor, with the connector facing downward, and the front of the antenna facing to the exterior of the building, preferably directed towards the Base Station.



**CAUTION**

In order to avoid damage from lightning strikes, the antenna must be placed below roof level.

### 2.5.5.1 Wall Mount

The installation kit includes 2 plastic anchors and 2 #8 screws.

- 1 If anchors are needed (wall-board, plaster board, etc.), drill two holes for the anchors using a 5 mm drill bit and insert anchors. Use a 9/64" drill bit for screwing directly into a solid surface (stud).
- 2 Fasten the antenna to the wall. Refer to Figure 2-15 for directions. Use the two #8 screws provided with the kit. Do not over tighten.
- 3 Connect the antenna cable to the connector located on the bottom side of the antenna. Hand tighten, do not use a wrench or a similar tightening tool. Do not over tighten.

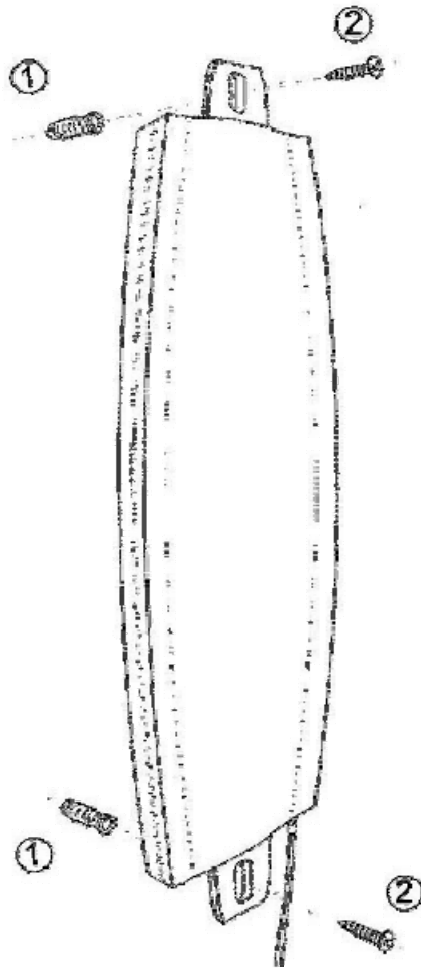

**Figure 2-15: Wall Mounting the Antenna**

### 2.5.5.2 Wall Mount with Rotation Capability

The installation kit includes 4 L-type mounting plates (one top, one bottom, one Wall-V and one Wall-H), 6 M5 screws (with washers and spring washers), 2 plastic anchors and 2 #8 screws.

- 1 If anchors are needed (wall-board, plaster board, etc.), drill two holes (361 mm apart) for the anchors using a 5 mm drill bit and insert anchors. Use a 9/64" drill bit for screwing directly into a solid surface (stud).
- 2 Assemble the top L-type plate with the Wall-V L-type plate. Note, the Wall-V plate is the one with the vertical ellipse on the short side. Make sure the inscriptions are facing upwards. Use two M5 screws to fasten the plates together. Do not over tighten. See Figure 2-16.
- 3 Assemble the bottom L-type plate with the Wall-H L-type plate. Note, the Wall-H plate is the one with the horizontal ellipse on the short side. Make sure the inscriptions are facing upwards. Use two M5 screws to fasten the plates together. Do not over tighten.

- 4 Attach the assembled plates to the flat rear-side of the antenna. Use the two remaining M5 screws to fasten them.
- 5 Fasten the antenna to the wall. Use the two #8 screws provided with the kit. Do not over tighten.
- 6 Connect the antenna cable to the connector located on the bottom side of the antenna. Use only the torque key supplied with the antenna. Do not over tighten. Do not use a wrench or a similar tightening tool.
- 7 Rotate the antenna left or right so the domed surface of the antenna is facing the direction of the Base Station. Check the received Signal LEDs to ensure the antenna is aimed correctly.

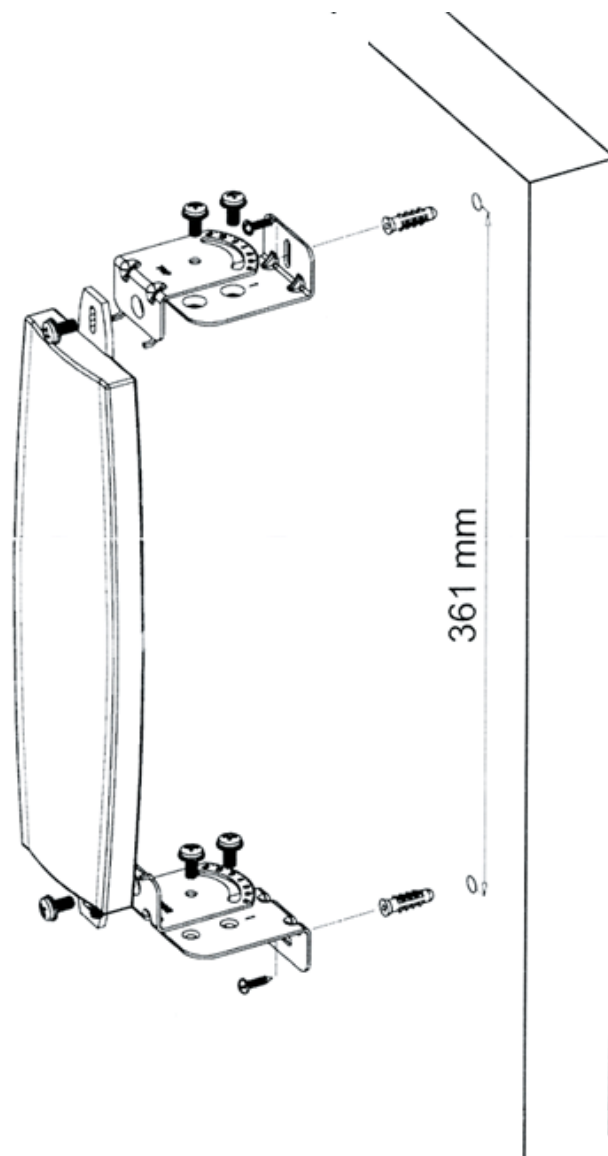

**Figure 2-16: Wall Mount with Rotation Capability**

### 2.5.5.3 Window Mount

The installation kit includes 2 suction cups.

- 1 Attach the suction cups to the antenna. Refer to Figure 2-17 for directions.
- 2 Determine the location of the antenna on the glass. Attach it to the window by pressing the suction cups onto the glass.
- 3 Connect the antenna cable to the connector located on the bottom side of the antenna. Use only the torque key supplied with the antenna. Do not over tighten. Do not use a wrench or a similar tightening tool.



#### CAUTION

The suction cups are sensitive to weather conditions and may not hold in high temperatures or during rain. It is strongly recommended to mount the antenna on the wall using the supplied brackets.

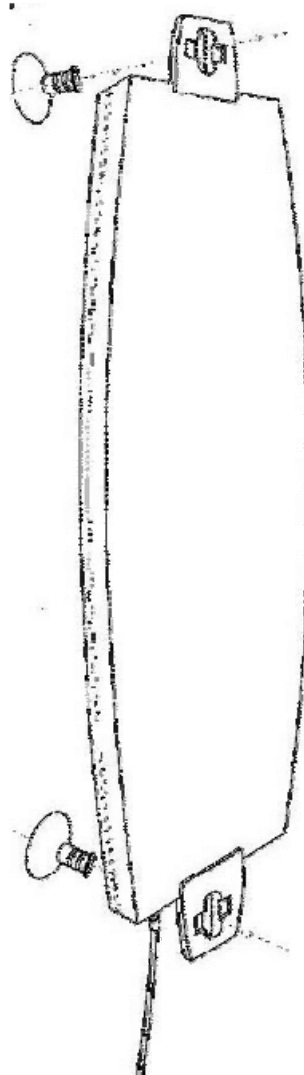

Figure 2-17: Window Mounting the Antenna

### 2.5.5.4 Window Mount with Rotation Capability

The installation kit includes the following: 4 PHK40\*16PT screws (1), 2 M4 washers (2), 2 rotation bars (3) and 2 suction cups (4).

- 1 Attach the rotation bars to the antenna and the suction cups to the rotation bars. Refer to Figure 2-18 for directions.
- 2 Determine the location of the antenna on the glass. Attach it to the window by pressing the suction cups onto the glass.
- 3 Connect the antenna cable to the connector located on the bottom side of the antenna. Use only the torque key supplied with the antenna. Do not over tighten. Do not use a wrench or a similar tightening tool.
- 4 Rotate the antenna left or right so the domed surface of the antenna is facing the direction of the Base Station. Check the received Signal LEDs to ensure the antenna is aimed correctly.

#### CAUTION



The suction cups are sensitive to weather conditions and may not hold in high temperatures or during rain. It is strongly recommended to mount the antenna on the wall using the supplied brackets.

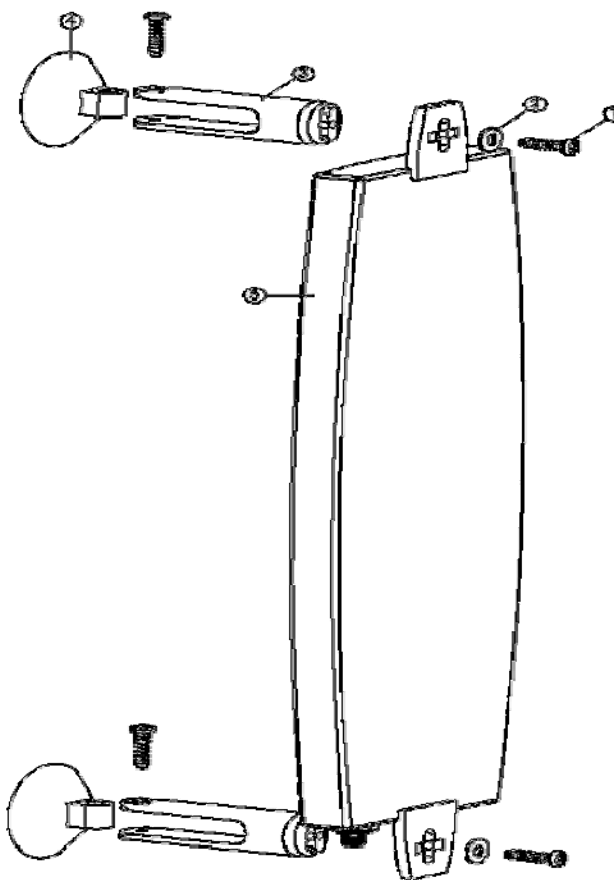

Figure 2-18: Window Mounting with Rotation Capability

## 2.6 Installing the Modular Base Station Equipment

The following sections describe the slot assignment for the Base Station chassis, provide illustrated descriptions of the power supply modules and Access Unit network interface modules, and describe how to install the Base Station equipment.

### 2.6.1 BS-SH Slot Assignment

The Base Station chassis comprises ten slots, as shown in Figure 2-19.

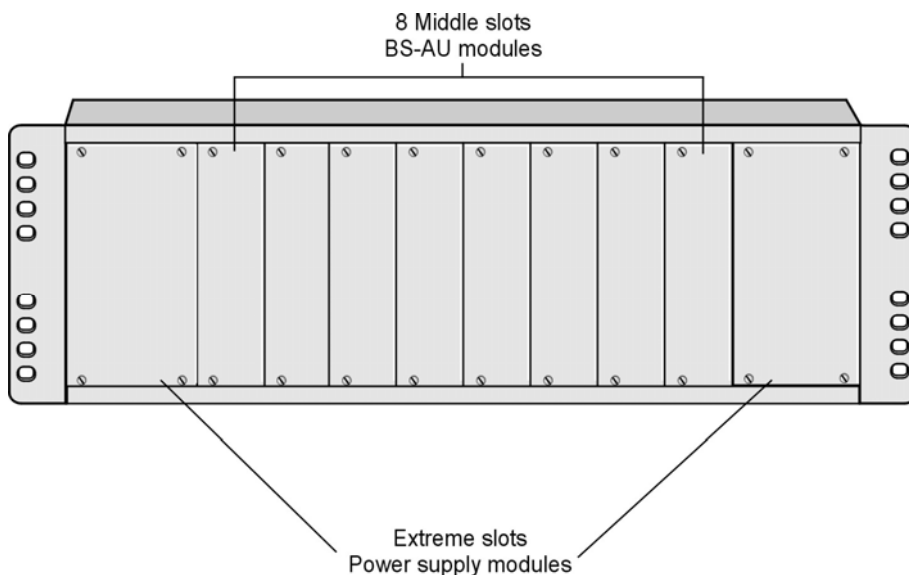

**Figure 2-19: BS-SH Chassis Slot Assignment**

To enable power supply redundancy, two BS-PS power supply modules can be installed in the wider side slots. If a single power supply module is used, it can be inserted into either one of the two available slots.

The remaining eight slots can hold up to six BS-AU modules. Unused slots should remain covered until required.

The design of the BS-SH supports collocation of BreezeACCESS VL Access Units with Access Units belonging to other BreezeACCESS families using GFSK modulation. It supports any mixture of BS-AU modules with BreezeACCESS GFSK BS-AU modules, including an optional BS-GU-GPS module. If Access Units belonging to other BreezeACCESS families are used, then it is necessary to use two power supply modules: one BS-PS (AC or DC) power supply for the BreezeACCESS VL Access Units and one BS-PS GFSK (AC or DC) for the BreezeACCESS GFSK Access Units.

## 2.6.2 BS-PS-AC Power Supply Module

The BS-PS-AC is an AC to DC converter that provides power to all the BS-AU modules installed in the BS-SH chassis. Figure 2-20 shows the BS-PS-AC front panel.

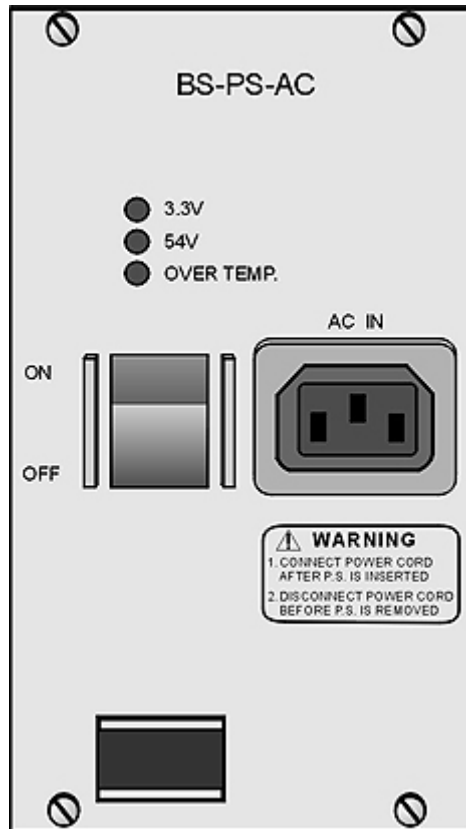

**Figure 2-20: BS-PS-AC Front Panel**

The BS-PS-AC includes a power input connector, marked AC IN, for connecting the AC power cord to the mains.

The ON/OFF Power Switch controls the flow of mains power to the power supply module.

<b>Name</b>	<b>Description</b>
54V	Green LED. Indicates that the 54V power supply module is OK
3.3V	Green LED. Indicates that the 3.3V power supply module is OK
OVER TEMP	Red LED. Indicates an over temperature condition in the power supply module

### 2.6.3 BS-PS-DC Power Supply Module

The BS-PS-DC is a DC-to-DC converter that provides power to all the BS-AU modules installed in the BS-SH chassis. Figure 2-21 shows the BS-PS-DC front panel.

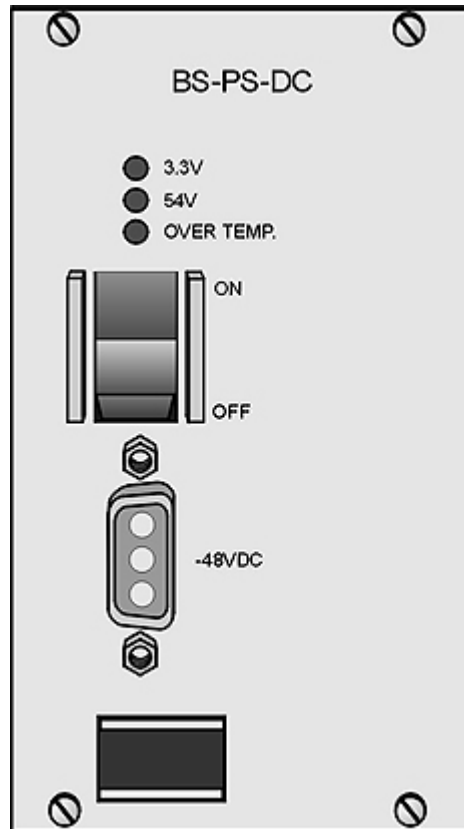

**Figure 2-21: BS-PS-DC Front Panel**

The BS-PS-DC provides a power input connector, marked -48VDC, for connecting the -48 VDC power source to the module.

The color codes of the cable wires are as follows:

- Black (pin 2): 48 VDC
- White (pin 1): + (Return)
- Shield (pin 3)

The ON/OFF Power Switch controls the flow of mains power to the power supply module.

The functionality of the LEDs is described in Table 2-6.

## 2.6.4 BS-AU Network Interface Module

Figure 2-22 shows the front panel of the BS-AU Access Unit Network Interface module.

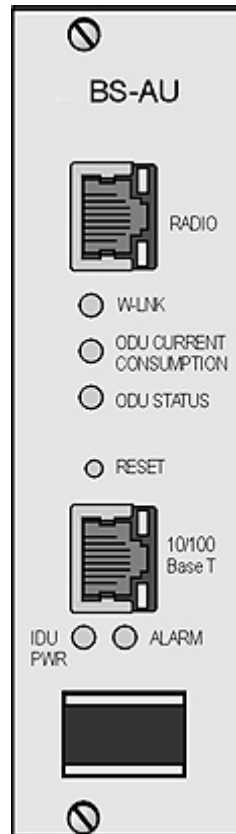

**Figure 2-22: BS-AU Front Panel**

The BS-AU provides the following interfaces:

- **10/100 BaseT:** A 10/100BaseT Ethernet connector for connecting the BS-AU to the network. A straight Ethernet cable should be used to connect the module to a hub, router or switch.
- **RADIO:** A 10/100BaseT Ethernet connector for connecting the BS-AU to an AU-ODU outdoor unit.

### CAUTION



Do not connect the data equipment to the RADIO port. The RADIO port supplies DC power to the ODU, and this may harm other equipment connected to it.

The recessed **RESET** switch on the front panel is for resetting the outdoor unit.

## 2.6.5 Installing the BS-SH Chassis and Modules

This section describes how to install the power supply and Access Unit network interface modules in the Base Station chassis.



### To install the BS SH chassis and modules:

- 1 Install the BS-SH chassis in a 19" cabinet. To prevent over-heating, leave a free space of at least 1U between the upper/lower covers of the BS-SH chassis and other units in the cabinet.

OR

Place the BS-SH chassis on an appropriate shelf or table. When mounting the BS-SH on a shelf or table, attach the rubber legs supplied with the unit.

- 2 Connect one end of a grounding cable to the ground terminal located on the rear panel of the BS-SH chassis and firmly tighten the grounding screw.
- 3 Connect the opposite end of the grounding cable to a ground connection or to the cabinet, if applicable.
- 4 Carefully insert the BS-PS power supply and the BS-AU modules into the relevant slots and push firmly until they are securely locked. Before insertion, verify that the switches of all BS-PS modules are in the OFF position. Refer to section [2.6.1](#) for a description of the slot assignment.
- 5 Close the captive screws attached to each module.
- 6 Place blank covers over all of the unused slots.
- 7 Connect the indoor-to outdoor cable(s) to the RADIO connector(s) of the BS-AU module(s).
- 8 If a BS-PS-DC power supply is used, connect the DC power cord to the -48 VDC IN jack of the BS-PS-DC power supply. If a redundant power supply module is installed, connect a DC power cord also to the second DC power module. Connect the power cord(s) to the -48 VDC power source, as follows:
  - a Connect the black wire to the -48 VDC contact of the power source.
  - b Connect the white wire to the + (Return) contact.
  - c Connect the shield to the ground.
- 9 If a BS-PS-AC power supply is used, connect the AC power cord to the AC IN jack of the BS-PS-AC power supply. If a redundant power supply module is installed, connect an AC power cord also to the second AC power module. Connect the power cord(s) to the mains outlet.
- 10 Switch the BS-PS-AC/DC power supplies to ON. Verify that all power indicator LEDs on the BS-PS-AC/DC front panel are ON and that the

OVERTEMP alarm indicator is off. Refer to Table 2-6 for a description of these LEDs.

- 11 Configure the basic parameters in all BS-AU modules as described in section [3.1](#).
- 12 Connect the 10/100 BaseT LAN connector(s) to the network. The cable connection should be straight Ethernet if connecting the indoor unit to a hub/switch and a crossed cable if connecting it directly to a PC Network Interface Card (NIC).



**NOTE**

- The length of each of the Ethernet cables (the cable connecting the indoor unit to the user's equipment and the Indoor-to-Outdoor cable) should not exceed 100 meters.
- Reset the unit using the RESET button after connecting or reconnecting the indoor and outdoor units with the indoor-to-outdoor cable.

---

## Chapter 3 - Commissioning

### About This Chapter:

- [Configuring Basic Parameters](#), page 70
- [Using the Optional Y-cable \(New SU-A/E-ODU\)](#), page 75
- [Aligning the Subscriber Unit Antenna](#), page 76
- [Configuring the Subscriber Unit's Maximum Modulation Level](#), page 78
- [Operation Verification](#), page 80

## 3.1 Configuring Basic Parameters

### 3.1.1 Initial Configuration

After completing the installation process, as described in the preceding chapter, the basic parameters must be configured to ensure that the unit operates correctly. After the basic parameters have been configured, additional parameters can be remotely configured via the Ethernet port or the wireless link using Telnet or SNMP management, or by loading a configuration file.

Refer to section [4.1](#) for information on how to access the Monitor program using Telnet and how to use it.

The *Basic Configuration* menu includes all the parameters necessary for the initial installation and operation of Subscriber and Access Units. In many installations, most of these parameters should not be changed from their default values. The basic parameters and their default values are listed in Table 3-1.

Refer to [Chapter 4](#) for detailed information on the applicable parameters.

<b>Parameter</b>	<b>Default Value</b>	<b>Comment</b>
Ethernet Port Negotiation Mode (in Unit Control Parameters)	Auto Negotiation	
IP Address	10.0.0.1	
Subnet Mask	255.0.0.0	
Default Gateway Address	0.0.0.0	
DHCP Options	Disable	
Access to DHCP	AU: From Ethernet Only SU: From Wireless Only	
ESSID	ESSID1	
Country Code Select	Depends on factory configuration	Applicable only for 5.4 and 5.8 GHz units. See 3.1.2 below.
Sub-Band Select (AU)	1	Applicable only if more than one Sub-Band is available
Frequency (AU)	The lowest frequency in the selected Sub-Band	

Table 3-1: Basic Parameters		
Parameter	Default Value	Comment
User Defined Frequency Subsets (SU)	All frequencies	
Transmit Power	Dependent on HW revision, unit type and Sub-Band	Transmit Power in SU cannot be higher than the Maximum Tx Power parameter.
Maximum Tx Power (SU)	Dependent on HW revision and Sub-Band	Maximum Tx Power cannot be higher than the upper limit according to the Sub-Band in use.
Tx Power (AU)	On	
Antenna Gain (units with external antenna)	According to the antenna supplied with the unit and the Sub-Band.	If set to "Not Set Yet", must be configured according to actual value, taking into account cable's attenuation.
ATPC Option	Enable	
Best AU Support (SU)	Disable	
Preferred AU MAC Address (SU)	00-00-00-00-00-00 (none)	Applicable only when Best AU Support is enabled.
Cell Distance Mode (AU)	Automatic	
Maximum Cell Distance (AU)	0 (No Compensation)	
Fairness Factor (AU)	100 (%)	
Per SU Distance Learning (AU)	Disable	
Maximum Modulation Level (SU)	8 (or the highest value supported according to the country code). Not higher than 7 for units with HW revision A.	Refer to section <a href="#">3.4</a> .
Wi2 IP Address (SU)	0.0.0.0 (none)	

<b>Parameter</b>	<b>Default Value</b>	<b>Comment</b>
VLAN ID-Management	65535	
Authentication Algorithm	Open System	Availability of security parameters depends on support according to the country code.
Data Encryption Option	Disable	
Security Mode	WEP	
Default Multicast Key (AU)	Key 1	
Promiscuous Authentication (AU)	Disable	
Default Key (SU)	Key 1	
Key 1 to Key 4	00.....0 (32 zeros, meaning no key)	

**NOTE**

Some parameters are changed to their new values only after reset (refer to Appendix E for more details). After the basic parameters are configured, the unit should be reset in order to activate the new configuration.

### 3.1.2 Country Code Selection

**CAUTION**

The selected Country Code must comply with applicable local radio regulations.

### 3.1.3 Transmit Power Compliance With Regulations



#### CAUTION

In regions where local radio regulations limit the maximum transmit power of the unit the installer is responsible to properly set the Antenna Gain parameter (if configurable) according to the actual antenna being used. This will limit the upper limits of the Tx Power parameter in the AU and the Maximum Tx Power in the SU (where applicable) to the value of "Permitted EIRP-Antenna Gain".

The Tx Power parameter in the AU and the Maximum Tx Power in the SU (where applicable) should not exceed the Permitted EIRP-Antenna Gain, according to the following table:

Country Code	Maximum EIRP (dBm)		
	20 MHz Bandwidth	10 MHz Bandwidth	5 MHz Bandwidth
Japan 4.9 GHz	34	34 (NOTE 1)	NA
FCC 5.3 GHz	30 (NOTE 3)	27 (NOTE 2)	NA
FCC 5.4 GHz	30	27	NA
ETSI 5.4 GHz	30	27	NA
ETSI-F 5.4 GHz	30	27	NA
Australia 5.4 GHz	30	27	NA
Universal 5.4 GHz	AU: 38 SU: 49	AU: 38 SU: 49	NA
FCC 5.8 GHz	AU: 36 SU: No Limit (PtMP)	AU: 36 SU: No Limit (PtMP)	NA
UK 5.8 GHz	36	33	NA
Australia 5.8 GHz	36	36	NA
India 5.8 GHz	36	33	NA
Germany 5.8 GHz	36	33	NA
Universal 5.8 GHz	AU: 36 SU: No Limit (PtMP)	AU: 36 SU: No Limit (PtMP)	NA
FCC 900 MHz	NA	NA	36

**NOTE 1** (Japan 4.9 GHz, 10 MHz Bandwidth):

In BreezeACCESS units operating in the 4.9 GHz Japan band (not B&B point-to-point) with a 10 MHz bandwidth, the following rules must be met for full compliance with regulations:

1. When operating at 4945 MHz, the Transmit Power parameter in the AU should not be set to a value above 11 dBm. The Maximum Transmit Power of the SU should not be set to a value above 10 dBm.
2. When operating at 5055 MHz, the Transmit Power parameter in the AU should not be set to a value above 13 dBm. The Maximum Transmit power of the SU should not be set to a value above 10 dBm.

This requirement, although not indicated in the certification document, is needed following the tests performed in the certification lab.

**NOTE 2** (FCC 5.3 GHZ, 10 MHz Bandwidth)

For full compliance with FCC regulation of units with HW rev C using a 10 MHz bandwidth, if you wish to include frequency channel 5265 MHz in the set of frequencies to be used, then the Transmit Power parameter in the AU, and the Maximum Tx Power parameter in the SUs, should not be set to a value above “25-Antenna Gain”. If there is a need to use a higher value for these parameters, this frequency should not be used.

**NOTE 3** (FCC 5.3 GHZ, 20 MHz Bandwidth)

For full compliance with FCC regulations, the following requirements should be followed in units using a 20 MHz bandwidth:

1. In units HW Revision B, if you wish to include frequency channel 5270 MHz in the set of frequencies to be used, then the Transmit Power parameter in the AU, and the Maximum Tx Power parameter in the SUs, should not be set to a value above “17-Antenna Gain”. If there is a need to use a higher value for these parameters, this frequency should not be used.
2. In units with HW Revision C, if you wish to include one or more of frequency channels 5270, 5275 and 5330 MHz in the set of frequencies to be used, then the Transmit Power parameter in the AU, and the Maximum Tx Power parameter in the SUs, should not be set to a value above “20-Antenna Gain”. If there is a need to use a higher value for these parameters, this frequency should not be used.

## 3.2 Using the Optional Y-cable (New SU-A/E-ODU)

A special Y-cable, available from Alvarion, enables to connect a portable PC directly to the IDU COM port of the SU-A/E-ODU. This enables the installer to perform the entire process of configuring basic parameters, aligning the antenna and verifying proper operation of the unit right after completing the installation, minimizing the number of times the installer must climb to the roof. It also enables simpler configuration/performance monitoring during various maintenance/testing actions.

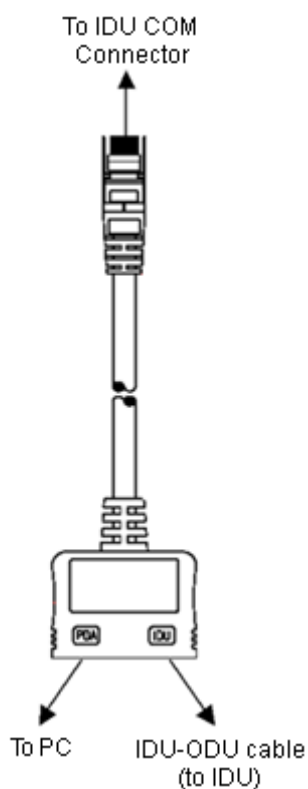

**Figure 3-1: Connecting the Y-cable**

### 3.3 Aligning the Subscriber Unit Antenna



#### NOTE

This antenna alignment process described in this section is applicable to both the SU-A-ODU and the SU-I antenna, unless stated otherwise.

The SNR bar display is located on the bottom panel of the SU-A-ODU/front panel of the SU-I indoor unit. The ten LEDs indicate the quality of the received signal. The higher the number of green LEDs indicating On, the higher the quality of the received signal. This section describes how to align the Subscriber Unit antenna using the SNR bar display.







#### NOTE

Antenna alignment using the SNR bar display is possible only after the Subscriber Unit is associated with an Access Unit. The associated Access Unit must be operational and the basic Subscriber Unit parameters must be correctly configured. Otherwise, the unit will not be able to synchronize with the Access Unit. As the SNR measurement is performed on received frames, its results are meaningless unless the Subscriber Unit is associated with an Access Unit.



#### To align the Subscriber Unit antenna:

- 1 Align the antenna by pointing it in the general direction of the Base Station.
- 2 Verify that the power indication of the unit (/) is **On**.
- 3 Verify that the W-LINK LED (/) of the ODU is **On**, indicating that the unit is associated with an Access Unit. If the W-LINK LED is **Off**, check that the **ESSID** and **Frequency** parameters are correctly configured. If the SU is still not associated with the AU, increase the transmit power level to its maximum value. If the unit is still not associated with the AU, improve the quality of the link by changing the direction of the antenna or by placing the antenna at a higher or alternate location.
- 4 Rotate the antenna until the maximum SNR reading is achieved, where at least 1 green LED is on. If you encounter prolonged difficulty in illuminating the minimum required number of green LEDs, try to improve the reception quality by placing the antenna at a higher point or in an alternate location.
- 5 Ensure that the front of the antenna is always facing the Base Station. However, in certain conditions, such as when the line of site to the Base Station is hampered, better reception may be achieved using a reflected signal. In this case, the antenna is not always directed toward the Base Station.
- 6 Secure the unit firmly to the pole (SU-A-ODU)/fasten the rotation screws (SU-I antenna).

**NOTE**

In some cases, the antenna may need to be tilted to ensure that the level at which the SU receives transmissions from the AU (and vice versa) is not too high. As a rule of thumb, if the SU is located at a distance of less than 300 meters from the AU, it is recommended to up-tilt the antenna by approximately 10° to 15°. To guarantee a safety margin from the saturation level, the SNR should not be higher than 50 dB. The orange LED of the SNR bar indicates that the SNR is higher than 50 dB.

## 3.4 Configuring the Subscriber Unit's Maximum Modulation Level

This section describes how to configure the maximum modulation level for Subscriber Units.



### NOTE

If the unit is associated with the AU, then the final configuration of the Maximum Modulation Level parameter may be performed remotely, for example, from the site of the AU or from another site.



### To configure the Maximum Modulation Level:

- 1 If the SNR of the SU at the AU is too low, it is recommended that you configure the *Maximum Modulation Level* parameter to a value that is lower than the maximum supported by the unit. This can decrease the number of retransmissions due to attempts to transmit at modulation levels that are too high for the actual quality of the link.
- 2 Check the SNR of the SU at the AU. You can use Telnet to view the SNR values in the *MAC Address Database*, which can be accessed from the *Site Survey* menu. If the ATPC algorithm is not enabled in both AU and SU, the test should be done with the *Initial Power Level* at the SU configured to its maximum value. If the SNR is lower than the values required for the maximum modulation level according to Table 3-3, it is recommended that you decrease the value of the Maximum Modulation Level.



### NOTE

The SNR measurement at the AU is accurate only when receiving transmissions from the applicable SU. If necessary, use the Ping Test utility in the Site Survey menu to verify data transmission.

- 3 Configure the *Maximum Modulation Level* according to Table 3-3, using the typical SNR values. It is recommended that a 2 dB margin be added to compensate for possible measurement inaccuracy or variance in the quality of the link.

<b>Table 3-3: Recommended Maximum Modulation Level*</b>	
<b>SNR</b>	<b>Maximum Modulation Level</b>
SNR > 23 dB	8
21 dB < SNR < 23 dB	7
16 dB < SNR < 21 dB	6
13 dB < SNR < 16 dB	5
10 dB < SNR < 13 dB	4
8 dB < SNR < 10 dB	3
7 dB < SNR < 8 dB	2
6 dB < SNR < 7 dB	1

\* The maximum supported value depends on the unit's HW revision and on the Max Modulation Level according to the Sub-Band.

## 3.5 Operation Verification

The following sections describe how to verify the correct functioning of the Outdoor Unit, Indoor Unit, Ethernet connection and data connectivity.

### 3.5.1 Outdoor Unit Verification

To verify the correct operation of the Outdoor Unit, examine the LED indicators located on the bottom panel of the outdoor unit.

The following tables list the provided LEDs and their associated indications.

#### NOTE



Verifying the correct operation of the Outdoor Unit using the LEDs, as described below, is only possible after the configuration and alignment processes are completed.







Name	Description	Functionality
W-LINK	 Wireless Link Indicator	<ul style="list-style-type: none"> <li>■ Green – Unit is associated with one or more SUs</li> <li>■ Blinking red – No associations</li> <li>■ Off – Wireless link is disabled</li> </ul>
Status	 Self-test and power indication	<ul style="list-style-type: none"> <li>■ Green – Power is available and self-test passed.</li> <li>■ Blinking Amber – Testing (not ready for operation)</li> <li>■ Red – Self-test failed – fatal error</li> </ul>
ETH	 Ethernet activity/ connectivity indication	<ul style="list-style-type: none"> <li>■ Green –Ethernet link detected.</li> <li>■ Amber – No Ethernet connectivity between the indoor and outdoor units.</li> </ul>

Table 3-5: SU-ODU LEDs		
Name	Description	Functionality
W-LINK	 Wireless Link Indicator	<ul style="list-style-type: none"> <li>■ Green – Unit is associated with an AU, no wireless link activity</li> <li>■ Blinking Green – Data received or transmitted on the wireless link. Blinking rate is proportional to wireless traffic rate</li> <li>■ Off – Wireless link is disabled</li> </ul>
Status	 Self-test and power indication	<ul style="list-style-type: none"> <li>■ Green – Power is available and self-test passed.</li> <li>■ Blinking Amber – Testing (not ready for operation)</li> <li>■ Red – Self-test failed – fatal error</li> </ul>
ETH	 Ethernet activity/ connectivity indication	<ul style="list-style-type: none"> <li>■ Green – Ethernet link between the indoor and outdoor units is detected, no activity</li> <li>■ Blinking Green – Ethernet connectivity is OK, with traffic on the port. Blinking rate proportional to traffic rate.</li> <li>■ Red – No Ethernet connectivity between the indoor and outdoor units.</li> </ul>
SNR BAR (SU-RA)	Received signal strength Indication	<ul style="list-style-type: none"> <li>■ Red LED: Signal is too low (SNR &lt; 4 dB)</li> <li>■ 8 green LEDs: Quality of the received signal</li> <li>■ Orange LED: Signal is too high (SNR &gt; 50 dB)</li> </ul>

<b>SNR Bar LEDs</b>	<b>SNR (typical)</b>
LED 1 (red) is On	Signal is too low (SNR < 4 dB)
LED 2 (green) is On	SNR > 4 dB
LEDs 2 to 3 (green) are On	SNR > 8 dB
LEDs 2 to 4 (green) are On	SNR > 13 dB
LEDs 2 to 5 (green) are On	SNR > 19 dB
LEDs 2 to 6 (green) are On	SNR > 26 dB
LEDs 2 to 7 (green) are On	SNR > 31 dB
LEDs 2 to 8 (green) are On	SNR > 38 dB
LEDs 2 to 9 (green) are On	SNR > 44 dB
LEDs 2 to 9 (green) and 10 (orange) are On	Signal is too high (SNR > 50 dB)

## 3.5.2 Indoor Unit Verification

To verify the correct operation of the indoor equipment, examine the LED indicators located on the top panel of the SU IDU and AU IDU units, or on the front panel of the BS-AU module.

Table 3-7 provides information for the BS-AU IDU LEDs. Table 3-8 lists the LEDs of the PS1073 IDU.



<b>Name</b>	<b>Description</b>	<b>Functionality</b>
W-LINK	Wireless link activity	<ul style="list-style-type: none"> <li>■ Green - At least one SU is associated.</li> <li>■ Blinking Red - No SU is associated.</li> <li>■ Off - Wireless link is disabled.</li> </ul>
ODU CURRENT CONSUMPTION	Current Consumption of the Outdoor Unit	<ul style="list-style-type: none"> <li>■ Red - over current.</li> <li>■ Blinking Red - open circuit or below anticipated current consumption.</li> <li>■ Green - within tolerance.</li> </ul>
ODU STATUS	Outdoor Unit Self-test	<ul style="list-style-type: none"> <li>■ Green - Self test passed and ODU ready for operation.</li> <li>■ Blinking Amber - Testing (not ready for operation)</li> <li>■ Red - fatal failure.</li> </ul>
IDU PWR	Power indication for the Indoor Unit	<ul style="list-style-type: none"> <li>■ Green - IDU power is OK.</li> <li>■ Off - no power is supplied to the IDU.</li> </ul>
ALARM	Indoor Unit Alarm Indication	<ul style="list-style-type: none"> <li>■ Red - a fatal failure indication.</li> <li>■ Off - IDU is functioning properly.</li> </ul>

<b>Name</b>	<b>Description</b>	<b>Functionality</b>
POWER	Power Indication	<ul style="list-style-type: none"> <li>■ Green – IDU power is OK</li> <li>■ Off – No power or power failure</li> </ul>
ETH	Self test and end-to-end Ethernet connectivity	<ul style="list-style-type: none"> <li>■ Off – No Ethernet connectivity has been detected between the outdoor unit and the device connected to the indoor unit.</li> <li>■ Green – Self-test passed and Ethernet connection confirmed by the outdoor unit (Ethernet integrity check passed).</li> </ul>

### 3.5.3 SU-I Unit Verification

To verify the correct operation of the SU-I unit, examine the LED indicators located on the front panel of the SU-I unit.

The following tables list the provided LEDs and their associated indications.

<b>Name</b>		<b>Description</b>	<b>Functionality</b>
	Status	Self-test and power indication	Green: Power is available and self-test passed. Blinking Amber: Testing (not ready for operation) Red: Self-test failed. Fatal error
	Ethernet	Ethernet activity/ connectivity indication	Green: Ethernet link between the SU-I and the data equipment is detected, no activity Blinking Green: Ethernet connectivity is OK, with traffic on the port. Blinking rate proportional to traffic rate. Red: No Ethernet connectivity between the SU-I and the data equipment.
	W-Link	Wireless Link traffic Indication	Green: Unit is associated with an AU, no wireless link activity Blinking Green: Data received or transmitted on the wireless link. Blinking rate is proportional to traffic rate. Off: Wireless link disabled

SNR Bar LEDs	SNR (typical)
LED 1 (red) is On	Signal is too low (SNR < 4 dB)
LED 2 (green) is On	SNR > 4 dB
LEDs 2 to 3 (green) are On	SNR > 8 dB
LEDs 2 to 4 (green) are On	SNR > 13 dB
LEDs 2 to 5 (green) are On	SNR > 19 dB
LEDs 2 to 6 (green) are On	SNR > 26 dB
LEDs 2 to 7 (green) are On	SNR > 31 dB
LEDs 2 to 8 (green) are On	SNR > 38 dB
LEDs 2 to 9 (green) are On	SNR > 44 dB
LEDs 2 to 9 (green) and 10 (orange) are On	Signal is too high (SNR > 50 dB)

### 3.5.4 Verifying the Ethernet Connection (Modular Base station)

After connecting the unit to an Ethernet outlet, verify that the Ethernet Integrity Indicator, which is the yellow LED embedded in the 10/100 BaseT connector, is on. This indicates that the unit is connected to an Ethernet segment. The Ethernet Activity Indicator, which is the green embedded LED, should blink whenever the unit receives or transmits traffic on the 10/100 BaseT port.

### 3.5.5 Verifying the Indoor-to-Outdoor Connection (Modular Base Station)

After connecting the unit to an Ethernet outlet, verify that the Ethernet Integrity Indicator, which is the yellow LED embedded in the **RADIO** connector, is on. This indicates that the unit has detected an Ethernet link connection. The Ethernet Activity Indicator, which is the green embedded LED, should blink whenever the unit receives or transmits traffic on the **RADIO** port.

### 3.5.6 Verifying Data Connectivity

To verify data connectivity, from the end-user's PC or from a portable PC connected to the unit, ping the Access Unit, or try to connect to the Internet.



# 4

---

## Chapter 4 - Operation and Administration

### In This Chapter:

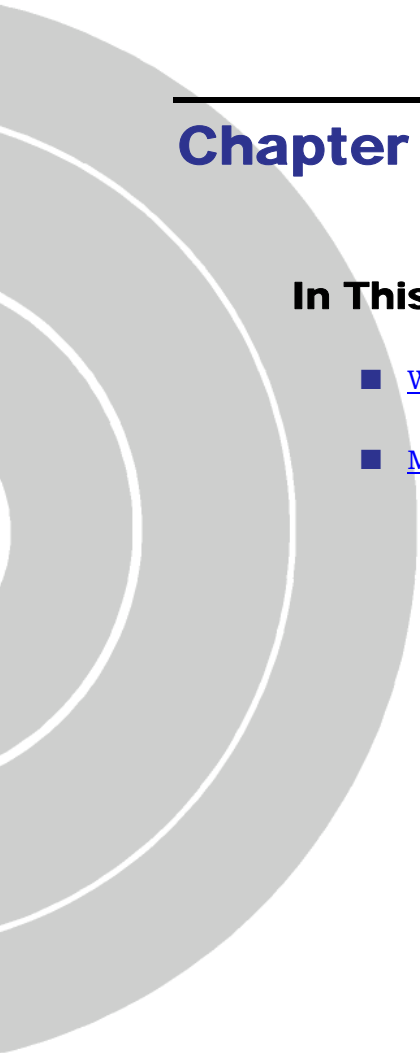
- [Working with the Monitor Program](#), page 88
  - [Menus and Parameters](#), page 91
- 

## 4.1 Working with the Monitor Program

### 4.1.1 Accessing the Monitor Program Using Telnet

- 1 Connect a PC to the Ethernet port, using a crossed cable.
- 2 Configure the PC's IP parameters to enable connectivity with the unit. The default IP address is 10.0.0.1.
- 3 Run the Telnet program. The *Select Access Level* menu is displayed.
- 4 Select the required access level, depending on your specific access rights. A password entry request is displayed. Table 4-1 lists the default passwords for each of the access levels.

Access Rights	Password
Read-Only	public
Installer	user
Administrator	private

#### NOTE



Following three unsuccessful login attempts (using incorrect passwords), the monitor program is blocked for several minutes. To enable access to the monitor program during that time, the unit must be reset via SNMP or by disconnecting/reconnecting power.

If you forgot the password, type "h" at the Access Level selection prompt. Type "Recover" at the prompt to get a challenge string consisting of 8 characters. Contact Alvarion's Customer Service and give them the challenge string (after user identification) to receive a one-time password. After entering this password at the prompt, the unit will reboot with the default Administrator password (private). Three consecutive errors in entering the one-time password will invalidate it and block the monitor program. A new challenge string should be used to receive a new one-time password.

- 5 Enter your password and press **Enter**. The *Main Menu* is displayed as shown in Figure 4-1. The unit type and location (if configured), SW version number and SW release date displayed in the **Main Menu** vary according to the selected unit and SW version.

```

BreezeACCESS VL/<Unit Type>/<Unit Location>
Official Release Version - <Version Number>
Release Date: <Date and Time>
Main Menu
=====
1 - Info Screens
2 - Unit Control
3 - Basic Configuration
4 - Site Survey
5 - Advanced Configuration
x - Exit
>>>

```

**Figure 4-1: Main Menu (Administrator Level)**



#### NOTE

If the Telnet session is not terminated properly; for example, if you simply close the window, the monitor program is blocked for several minutes. To enable access to the monitor program during that time, the unit must be reset via SNMP or by disconnecting/reconnecting power.

The display of the *Main Menu* varies depending on the user's access level, as follows.

- For users with read only access rights, only the *Info Screens* option is displayed. Users with this access level are not able to access the *Unit Control*, *Basic Configuration*, *Site Survey* and *Advanced Configuration* menus.
- For users with Installer access rights, the first four menu items, *Info Screens*, *Unit Control*, *Basic Configuration* and *Site Survey*, are displayed. Users with this access level are not able to access the *Advanced Configuration* menu.
- For users with Administrator access rights, the full *Main Menu* is displayed. These users can access all menu items.

## 4.1.2 Common Operations

The following describes the standard operations used when working with the Monitor program.

- Type an option number to open or activate the option. In certain cases you may need to click **Enter**.
- Click Esc to exit a menu or option.



**NOTE**

The program is automatically terminated following a determined period of inactivity. The default time out is 5 minutes and is configured with the Log Out Timer parameter.

In some cases, to activate any configuration changes, you must reset the unit. Certain settings are automatically activated without having to reset the unit. Refer to Appendix E for *information* on which parameters are run time configurable, which means that the unit need not be reset for the parameter to take effect, and which parameters do require that the unit be reset.

## 4.2 Menus and Parameters

The following sections describe the menus and parameters provided by the Monitor program.

### 4.2.1 Main Menu

The *Main Menu* enables to access the following menus, depending on your access level, as described in section [4.1](#).

- **Info Screens:** Provides a read only display of current parameter values. Available at all access levels.
- **Unit Control:** Enables to access general operations, such as resetting the unit, reverting to factory default parameters, changing passwords and switching between software versions. Available at the Installer and Administrator access levels.
- **Basic Configuration:** Enables to access the set of parameters that are configured during the installation process. These parameters are also available in the *Advanced Configuration* menu. Available at the Installer and Administrator access levels.
- **Site Survey:** Enables to activate certain tests and view various system counters. Available at the Installer and Administrator access levels.
- **Advanced Configuration:** Enables to access all system parameters, including the *Basic Configuration* parameters. Available only at the Administrator access level.

### 4.2.2 Info Screens Menu

The Info Screens menu enables you to view the current values of various parameter sets. The parameter sets are identical to the main parameter groups in the configuration menus. You can view a specific parameter set or choose to view all parameters at once. While this menu is available at all access levels, some security related parameters including the encryption Keys, ESSID and Operator ESSID are only displayed to users with Administrator access rights.

The Info Screens menu includes the following options:

- Show Unit Status
- Show Basic Configuration

- Show Advanced Configuration
- Show Country Dependent Parameters
- Show All Parameters

### 4.2.2.1 Show Unit Status

The Show Unit Status menu is a read only menu that displays the current values of the following parameters:

- **Unit Name:** As defined in the Unit Control menu.
- **Unit Type:** Identifies the unit's function.
- **Unit MAC Address:** The unit's unique IEEE MAC address.
- **Current Number of Associations (AU only):** The total number of SUs associated with this AU. This number may include units that are not currently active or associated.



#### NOTE

An SU is only removed from the list of associated SUs under the following conditions:

- The SU failed to respond to 100 consecutive data frames transmitted by the AU and is considered to have "aged out".
  - During the last 6 minutes (or more) the SU did not transmit any data frame, and failed to respond to certain frames that typically are transmitted by the AU every 10 seconds. Since the sampling interval for this state is about 10 minutes, it means that the decision to remove the SU from the Associations Database will take place between 6 to 16 minutes from the time the SU ceased sending data or responding to these "keep-alive" frames (for AUS the sampling interval is 1 minute, meaning decision time of 6 to 7 minutes).
- 
- **Number of Associations Since Last Reset:** For SUs - displays the total number of associations with any AU since the last reset, including duplicate associations with the same AU. For AUs - displays the number of SUs that have associated with the AU since the last reset, including duplicate associations with the same SU.
  - **Unit Status (SU only):** The current status of the SU. There are three status options:
    - ◇ **SCANNING:** The SU is searching for an AU with which to associate. If DFS is enabled and the SU is currently looking for its previous AU, the AU's MAC Address will be displayed.

- ◇ **ASSOCIATED:** The SU is associated with an AU.
- ◇ **AUTHENTICATING:** This is typically a temporary status. For example, when an SU hears the beacons of an AU, tries to associate and the AU does not respond because it does not hear the SU's packets.
- **AU MAC Address (SU only):** The MAC address of the AU with which the unit is currently associated. If the unit is not associated with any AU, the address defaults to the IEEE broadcast address, which is FF-FF-FF-FF-FF-FF.
- **Unit Hardware Version:** The version of the outdoor unit hardware.
- **Unit BOOT Version:** The version of the BOOT SW.
- **Time Since Last Reset**
- **Flash Versions:**
  - ◇ **Running from:** Shows whether the unit is running from the Main or from the Shadow Version.
  - ◇ **Main Version File Name:** The name of the compressed file (with a “.bz” extension) of the version currently defined as the main version.
  - ◇ **Main Version Number:** The software version currently defined as the main version.
  - ◇ **Shadow Version File Name:** The name of the compressed file (with a “.bz” extension) of the version currently defined as the shadow (backup) version.
  - ◇ **Shadow Version Number:** The software version currently defined as the shadow (backup) version.
- **Radio Band:** The radio band of the unit.
- **Log Out Timer:** The value of the Log Out Timer as defined in the Unit Control menu.
- **Country Code:** The 3 or 4 digits Country Code used by the unit and its general description.
- **Ethernet Port Negotiation Mode:** The Ethernet port negotiation mode as defined in the Unit Control menu.
- **Ethernet Port State:** The actual state of the Ethernet port.

- **FTP Parameters:** General FTP parameters (common to SW Version Download, Configuration File Upload/Download and Event File Upload using FTP):
  - ◇ FTP Server IP Address
  - ◇ FTP Gateway IP Address
  - ◇ FTP User Name
  - ◇ FTP Password
  
- **FTP Software Download Parameters:** The parameters for SW download using FTP, as defined in Unit Control menu.
  - ◇ FTP SW Version File Name
  - ◇ FTP Source Directory
  
- **Configuration File Download/Upload Parameters:** The parameters for Configuration file upload/download using FTP, as defined in the Unit Control menu.
  - ◇ Configuration File Name
  - ◇ Configuration File Source Directory
  - ◇ Operator Defaults File Name
  
- **FTP Log File Upload Parameters:** The parameters for Event Log file upload using FTP, as defined in the Unit Control menu.
  - ◇ FTP Log File Name
  - ◇ FTP Log File Destination Directory
  
- **Event Log Minimum Severity**
  
- **ATE Test Status:** Indicates the result of the unit's final testing in production. In units supplied with SW version 4.5 and higher should always be PASS. In units upgraded from a version below 4.5 this parameter will be NONE.
  
- **Serial Number:** The Serial Number of the unit. Applicable only to units supplied with SW version 4.5 and higher. In units upgraded from a version below 4.5 this parameter will be none (empty).

- **SU-54 Support (AUS only):** Supported or Not Supported. Indicates whether the AUS can support SU-54 units (support of SU-54 units by AUS is a licensed feature available for all AUS units except AUS operating in the 0.9 GHz band).
- **Wireless Link Prioritization Support (AU only):** Supported or Not Supported. Indicates whether the unit supports the Wireless Link Prioritization feature (Wireless Link Prioritization is a licensed feature).

#### 4.2.2.2 Show Basic Configuration

The Show Basic Configuration menu is a read only menu that displays the current values of the parameters included in the Basic Configuration menu.

#### 4.2.2.3 Show Advanced Configuration

The Show Advanced Configuration menu enables to access the read only sub menus that display the current values of the parameters included in the applicable sub menus of the Advanced Configuration menu.

#### 4.2.2.4 Show Country Dependent Parameters

Each country has its radio regulation regarding transmissions in the applicable bands that affect parameters such as available frequencies, bandwidth, transmit power, etc. Some other parameters and options may also vary among countries. For each country, one or more sets of parameters are pre-configured in the factory. If more than one set is available, the set to be used can be selected. The Show Country Dependent Parameters displays the available set(s) of these parameters, and includes the following:

- **Country Code:** The up to 3 digits country code according to ISO 3166 and the country name. Some regulatory requirements apply to more than one country. In these cases the Country Code includes a 4 digits proprietary group code and the Country Group name (for example FCC).
- **Data Encryption Support:** Indicates whether data encryption is supported for the applicable country.
- **AES Encryption Support:** Indicates whether encryption using AES is supported for the applicable country.
- **Authentication Encryption Support:** Indicates whether authentication encryption is supported for the applicable country.

For each of the available sets (Sub-Bands), the following information is provided:

- **Sub-Band ID and Frequencies**

- **Allowed Bandwidth:** If more than one bandwidth is allowed, then each bandwidth is associated with a different sub-band, as the bandwidth may affect the available frequencies.
- **Regulation Max Tx Power at Antenna Port:** The maximum transmit power allowed at the antenna port of the unit.
- **Regulation Max EIRP:** The maximum allowed EIRP (Effective Isotropic Radiated Power) in dBm, or No Limit.
- **Min Modulation Level:** The lowest allowed modulation level.
- **Max Modulation Level:** The highest allowed modulation level.
- **Burst Mode:** Indicates whether Burst Mode operation is allowed.
- **Maximum Burst Duration:** If Burst Mode is allowed, this parameter displays the upper limit for the Maximum Burst Duration.
- **DFS Option:** Indicates whether the DFS (Dynamic Frequency Selection) mechanism for identification and avoidance of channels with radar activity is supported.
- **Minimum HW Revision Support:** The minimum HW revision required to support the Sub-Band.

New Country Code files can be uploaded remotely using TFTP (see [Appendix B](#)).

### 4.2.2.5 Show All Parameters

The Show All Parameters menu is a read only menu that displays the current values of all status and configuration parameters.



#### NOTE

The values of some security related parameters, including the encryption Keys, ESSID and Operator ESSID, are available only with Administrator access rights.

### 4.2.3 Unit Control Menu

The Unit Control menu enables configuring control parameters for the unit. The Unit Control menu includes the following options:

- Reset Unit
- Default Settings

- Change Unit Name
- Change Password
- Flash Memory Control
- Log Out Timer
- Ethernet Negotiation Mode
- Change System Location
- Event Log Menu
- Feature Upgrade
- SW Version Download
- Configuration File Upload/Download

#### 4.2.3.1 **Reset Unit**

The Reset Unit option enables resetting the unit. After reset, any modifications made to the system parameters are applied.

#### 4.2.3.2 **Default Settings**

The Set defaults submenu enables resetting the system parameters to a predefined set of defaults or saving the current configuration as the set of Operator Defaults.

The Default Setting options are available only to users with Administrator access rights.

The available options are:

- Set Defaults
- Save Current Configuration As Operator Defaults

##### 4.2.3.2.1 **Set Defaults**

The Set Defaults submenu enables reverting the system parameters to a predefined set of defaults. There are two sets of default configurations:

- A** Factory Defaults: This is the standard default configuration.

- B** Operator Defaults: Operator Defaults configuration can be defined by the Administrator using the Save Current Configuration As Operator Defaults option in this menu. It may also be defined at the factory according to specific operator's definition. The default Operator Defaults configuration is the Factory Defaults configuration.

The current configuration file and the Operator Defaults configuration file can be uploaded/downloaded by the unit using FTP. For more information, see section [4.2.3.12](#) option. These files can also be uploaded/downloaded remotely using TFTP (see [Appendix B](#)).

The available options in the Set Defaults submenu are:

- Set Complete Factory Defaults
- Set Partial Factory Defaults
- Set Complete Operator Defaults
- Set Partial Operator Defaults
- Cancel Current Pending Request

#### 4.2.3.2.1.1 Set Complete Factory Defaults

Select this option to reset the unit to the standard Factory Defaults configuration, excluding several parameters that are listed in Table 4-2.

<b>Parameters Group</b>	<b>Parameter</b>
Unit Control Parameters	All Passwords
	FTP Server IP address* (see note below)
	FTP Gateway IP address* (see note below)
	FTP User Name* (see note below)
	FTP Password* (see note below)
	Ethernet Port Negotiation Mode
Air Interface Parameters	Selected Sub-Band (AU)
	Frequency (AU)
	DFS Required by Regulations (AU)
	Frequency Subset (AU)
	Antenna Gain (AU)
Country Code Parameters	Selected Country Code

**NOTE**

The FTP parameters are not set to their default values after Set Complete Operator Defaults. However, they are set to their default value after Set Complete Factory Defaults. Note that in this case they are set to the default values immediately upon selecting the Set Complete Factory Default option (even before the next reset).

#### 4.2.3.2.1.2 Set Partial Factory Defaults

Select this option to reset the unit to the standard Factory Default configuration, excluding the parameters that are required to maintain connectivity and management access. The parameters that do not change after Set Partial Factory Defaults are listed in Table 4-3.

<b>Parameters Group</b>	<b>Parameter</b>
Unit Control parameters	Passwords
	Ethernet Port Negotiation Mode
	FTP Server IP address

<b>Parameters Group</b>	<b>Parameter</b>
	FTP Gateway IP Address
	FTP User Name
	FTP Password
IP Parameters	IP Address
	Subnet Mask
	Default Gateway Address
	DHCP Option
	Access to DHCP
Security Parameters	Authentication Algorithm
	Default Key (SU)
	Data Encryption Mode
	Default Multicast Key (AU)
	Security Mode
	Key # 1 to Key # 4

<b>Table 4-3: Parameters that are not changed after Set Partial Factory/Operator Defaults</b>	
<b>Parameters Group</b>	<b>Parameter</b>
Air Interface Parameters	ESSID
	Operator ESSID Option (AU)
	Operator ESSID (AU)
	Cell Distance Mode (AU)
	Maximum Cell Distance (AU)
	Per SU Distance Learning Option (AU)
	Selected Sub-Band (AU)
	Frequency (AU)
	DFS Required by Regulations (AU)
	SU Waiting Option (AU)
	Channel Reuse Option (AU)
	Radar Activity Assessment Period (AU)
	Maximum Number of Detections in Assessment Period (AU)
	Frequency Subset (AU)
	ATPC Option (AU)
	Transmit Power
	Maximum Tx Power (SU)
	Tx Control (AU)
	Best AU Support (SU)
	Preferred AU MAC Address (SU)
All Noise Immunity Control parameters	
All Noise Floor Calculation parameters	

<b>Table 4-3: Parameters that are not changed after Set Partial Factory/Operator Defaults</b>	
<b>Parameters Group</b>	<b>Parameter</b>
Network Management Parameters	Wi2 IP Address (SU)
Performance Parameters	Adaptive Modulation Decision Thresholds
Bridge Parameters	VLAN ID – Management
	Service Provider VLAN ID (SU)
	VLAN QinQ Protocol Ethertype
	MAC Address List (AU)
	MAC Address List Action (AU)
Service Parameters	DRAP Option (AU)
	UDP Port (AU)
	Max Number of Voice Calls (AU)
	DRAP TTL (AU)
	Wireless Link Prioritization Option (AU)
	Low Priority AIFS (AU)
	Number of HW Retries for High Priority Traffic (AU)
	Number of HW Retries for Low Priority Traffic (AU)
	AU Burst Duration for High Priority Traffic (AU)
	AU Burst Duration for Low Priority Traffic (AU)
	SU Burst Duration for High Priority Traffic (AU)
	SU Burst Duration for Low Priority Traffic (AU)
	Low Priority Traffic Minimum Percent
Country Code Parameters	Selected Country Code

#### 4.2.3.2.1.3 Set Complete Operators Defaults

Select this option to reset the unit to the Operator Defaults configuration, excluding several parameters that are listed in Table 4-2.

#### 4.2.3.2.1.4 Set Partial Operator Defaults

Select this option to reset the unit to the Operator Defaults configuration, excluding the parameters that are required to maintain connectivity and management access. The parameters that do not change after Set Partial Operator Defaults are listed in Table 4-3.

#### 4.2.3.2.1.5 Cancel Current Pending Request

After selecting one of the Set defaults options, it will be executed after the next reset. This option enables to cancel the pending request before execution (provided the unit has not been reset yet).

#### 4.2.3.2.2 Save Current Configuration As Operator Defaults

The Save Current Configuration As Operator Defaults enables defining the current configuration of the unit as the Operator Defaults configuration.

### 4.2.3.3 Change Unit Name

The Change Unit Name option enables changing the name of the unit, which is also the system's name in the MIB2. The name of the unit is also used as the prompt at the bottom of each Monitor window.

Valid values: A string of up to 32 printable ASCII characters.

The default unit name is an empty string.

### 4.2.3.4 Change Password

The Change Password submenu enables changing the access password(s). The Change Password submenu is available only to users with Administrator access rights.

Valid values: A string of up to 8 printable ASCII characters.

Refer to section [4.1](#) for a list of the default passwords for each of the access levels.

### 4.2.3.5 Flash Memory Control

The Flash Memory Control submenu enables selecting the active software version for the unit.

The flash memory can store two software versions. One version is called Main and the other is called Shadow. New software versions are loaded as the shadow version. You can select the shadow version as the new active version by selecting **Reset and Boot from Shadow Version**. However, after the next reset, the main version is re-activated. To continue using the currently active version after the next reset, select **Use Running Version After Reset**: The previous shadow version will be the new main version, and vice versa.

The parameters configured in the unit are not changed as a result of loading new software versions unless the new version includes additional parameters or additional changes in the list of parameters. New parameters are loaded with their default values.

Select from the following options:

- **Reset and Boot from Shadow Version:** Activates the shadow (backup) software version. The unit is reset automatically. Following the next reset the unit will switch to the main version.
- **Use Running Version After Reset:** Defines the current running version as the new main version. This version will also be used following the next reset.

### 4.2.3.6 Log Out Timer

The Log Out Timer parameter determines the amount of inactive time following which the unit automatically exits the Monitor program.

The time out duration can range from 1 to 999 minutes.

The default value is 5 minutes.

### 4.2.3.7 Ethernet Negotiation Mode

The Ethernet Port Negotiation Mode submenu displays the current Ethernet port state and enables defining the negotiation mode of the Ethernet port. The available options are:

- Force 10 Mbps and Half-Duplex
- Force 10 Mbps and Full-Duplex
- Force 100 Mbps and Half-Duplex
- Force 100 Mbps and Full-Duplex
- Auto Negotiation (10/100 Mbps and Half/Full Duplex)

The default is Auto Negotiation (10/100 Mbps and Half/Full Duplex)

### 4.2.3.8 Change System Location

The Change System Location option enables changing the system location of the unit, which is also the sys location in MIB2. The System Location is also displayed as a part of the Monitor menu's header.

Valid values: A string of up to 35 printable ASCII characters.

The default system location is an empty string.

### 4.2.3.9 Event Log Menu

The Event Log Menu enables controlling the event log feature. The event log is an important debugging tool and a flash memory sector is dedicated for storing it. Events are classified according to their severity level: Message (lowest severity), Warning, Error or Fatal (highest severity).

The severity level of events that should be saved in the Event Log is configurable. Events from the configured severity and higher are saved and may be displayed upon request. Log history can be displayed up to the full number of current active events. In the log, an event is defined as active as long as it has not been erased (a maximum of 1000 events may be stored). The Event Log may be read using TFTP, with remote file name <SNMP Read Community>.log (the default SNMP Read Community is “public”). The Event Log may also be uploaded to a remote FTP server.

The Event Log Menu includes the following options:

- Event Log Policy
- Display Event Log
- Erase Event Log
- Event Load Upload

#### 4.2.3.9.1 Event Log Policy

The Event Log Policy determines the minimal severity level. All events whose severity is equal to or higher than the defined severity are logged.

Valid values are: Message (MSG) Level, Warning (WRN) Level, Error (ERR) Level, Fatal (FTL) Level, Log None.

The default selection is Warning Level severity.

#### 4.2.3.9.2 Display Event Log

The Display Event Log option enables viewing how many events are logged and selecting the number of events to be displayed (up to 1000). The display of each event includes the event time (elapsed time since last reset), the severity level and a message string. The events are displayed according to the time at which they were generated, with the most recent event displayed last (first in – first out).

#### 4.2.3.9.3 Erase Event Log

The Erase Event Log option enables clearing the event log.

#### 4.2.3.9.4 Event Log Upload

The Event Log Upload submenu enables the optional uploading of the event log file to a remote FTP server. The Event Log Upload submenu includes the following options:

- **FTP Event Log Upload Execute:** The FTP event Log Upload Execute executes the upload of the Event Log file according to the parameters defined below.

- **Event Log Destination Directory:** The Event Log Destination Directory enables defining the destination directory for the Event Log File.

Valid values: A string of up to 80 printable ASCII characters. To clear the field press "."

The default is an empty string.

- **Event Log File Name:** The Event Log File Name option enables defining the name of the event log file to be uploaded.

Valid values: A string of up to 20 printable ASCII characters.

The default is logfile.log.

- **FTP Server IP Address:** The FTP Host IP Address option enables defining the IP address of the FTP server that is hosting the file.

The default is: 10.0.0.253

- **FTP Gateway IP Address:** The FTP Gateway IP Address option enables defining the FTP default gateway address.

The default is: 0.0.0.0.

- **FTP User Name:** The FTP User Name option enables defining the user name to be used for accessing the FTP server that is hosting the file.

Valid values: A string of up to 18 printable ASCII characters.

The default is: vx

- **FTP Password:** The FTP Password option enables defining the password to be used for accessing the FTP server that is hosting the file.

Valid values: A string of up to 18 printable ASCII characters.

The default is: vx

- **Show FTP Event Log File Upload Parameters:** Displays the current values of the Event Log Upload parameters.

**NOTE**

There is one set of general FTP parameters (FTP Server IP Address, FTP Gateway IP Address, FTP User Name and FTP Password). This set (or relevant parts of the set) serves the SW Download procedure, the Configuration File Upload/Download procedure and the Event Log File Upload procedure. Changing any of these parameters in the menu for either procedure will automatically change its value in the menu for the other procedures.

### 4.2.3.10 Feature Upgrade

The Feature Upgrade option enables to enter a license string for upgrading the unit to support new features and/or options. Upon selecting the Manual Feature Upgrade option the user will be requested to enter the license string. Each license string is associated with a unique MAC Address and one feature/option. If the encrypted MAC Address in the license string does not match the unit's MAC Address, the string will be rejected. If there is a match, a message notifying of the new feature/option will be displayed. The unit must be reset for the change to take effect.

The license string comprises 32 to 64 hexadecimal digits.

**NOTE**

If you are entering the license string using copy and paste operation, check carefully that the string is copied properly. You may have to enter it manually due to potential problems in performing copy and paste in Telnet.

New Feature License files can be uploaded remotely using TFTP (see [Appendix B](#)).

### 4.2.3.11 SW Version Download

The SW Version Download submenu enables the optional downloading of a SW Version file from a remote FTP server. The SW Version Download submenu includes the following options:

- **Execute FTP GET SW Version:** The Execute FTP GET SW Version option executes the SW Version FTP download according to the parameters defined below.
- **FTP SW Source Dir:** The FTP SW Source Dir option enables defining the source directory of the SW version file.

Valid values: A string of up to 80 printable ASCII characters. To clear the field press "."

The default is an empty string.

- **FTP SW Version File Name:** The FTP SW Version File Name option enables defining the name of the SW version file in the FTP server.

Valid values: A string of up to 20 printable ASCII characters. An empty string is not allowed.

The default is VxWorks.bz.

- **FTP Server IP Address:** The FTP Server IP Address option enables defining the IP address of the FTP server that is hosting the SW Version file.

The default is: 10.0.0.253.

- **FTP Gateway IP Address:** The FTP Gateway IP Address option enables defining the FTP default gateway address.

The default is: 0.0.0.0.

- **FTP User Name:** The FTP User Name option enables defining the user name to be used for accessing the FTP server that is hosting the SW Version file.

Valid values: A string of up to 18 printable ASCII characters.

The default is: vx

- **FTP Password:** The FTP Password option enables defining the password to be used for accessing the FTP server that is hosting the SW Version file.

Valid values: A string of up to 18 printable ASCII characters.

The default is: vx

- **Show SW Version Download Parameters and Status:** Displays the current values of the SW Version Download parameters, the current SW version and the SW versions stored in the Flash memory.

#### NOTE



There is one set of general FTP parameters (FTP Server IP Address, FTP Gateway IP Address, FTP User Name and FTP Password). This set (or relevant parts of the set) serves the SW Download Procedure, the Configuration File Upload/Download procedure and the Event Log File Upload procedure. Changing any of these parameters in the menu for any procedure will automatically change its value in the menu for the other procedures.

### 4.2.3.12 Configuration File Upload/Download

The Configuration File Upload/Download submenu enables the optional uploading or downloading of a configuration or an Operator Defaults file from a

remote FTP server. The Configuration File Upload/Download submenu includes the following options:

- **Execute FTP GET/PUT Configuration File:** The Execute FTP GET/PUT Configuration File executes the upload/download of a Configuration file or an Operator Defaults file according to the parameters defined below. The following options are available:

- ◇ Execute FTP Get Configuration File (cfg)
- ◇ Execute FTP Put Configuration File (cfg)
- ◇ Execute FTP Get Operator Defaults File (cmr)
- ◇ Execute FTP Put Operator Defaults File (cmr)

- **FTP Configuration File Source Dir:** The FTP Configuration File Source Dir option enables defining the source directory of the configuration/Operator Defaults file.

Valid values: A string of up to 80 printable ASCII characters. To clear the field press "."

The default is an empty string.

- **Configuration File FTP File Name:** The Configuration File FTP File Name option enables defining the name of the configuration file to be uploaded/downloaded.

Valid values: A string of up to 20 printable ASCII characters. An empty string is not allowed.

The default is config.cfg.

- **Operator Defaults FTP File Name:** The Operator Defaults File Name option enables defining the name of the Operator Defaults file to be uploaded/downloaded.

Valid values: A string of up to 20 printable ASCII characters. An empty string is not allowed.

The default is operator.cmr.

- **FTP Server IP Address:** The FTP Host IP Address option enables defining the IP address of the FTP server that is hosting the file.

The default is: 10.0.0.253

- **FTP Gateway IP Address:** The FTP Gateway IP Address option enables defining the FTP default gateway address.

The default is: 0.0.0.0.

- **FTP User Name:** The FTP User Name option enables defining the user name to be used for accessing the FTP server that is hosting the file.

Valid values: A string of up to 18 printable ASCII characters.

The default is: vx

- **FTP Password:** The FTP Password option enables defining the password to be used for accessing the FTP server that is hosting the file.

Valid values: A string of up to 18 printable ASCII characters.

The default is: vx

- **Show Configuration File Upload/Download Parameters:** Displays the current values of the Configuration File Upload/Download parameters.

#### NOTE



There is one set of general FTP parameters (FTP Server IP Address, FTP Gateway IP Address, FTP User Name and FTP Password). This set (or relevant parts of the set) serves the SW Download procedure, the Configuration File Upload/Download procedure and the Event Log File Upload procedure. Changing any of these parameters in the menu for either procedure will automatically change its value in the menu for the other procedures.

## 4.2.4 Basic Configuration Menu

The Basic Configuration menu includes all parameters required for the initial installation and operation of the unit. After the unit is properly installed and operational, additional parameters can be configured either locally or remotely using Telnet or SNMP management.



### NOTE

All parameters in the Basic Configuration menu are also available in the relevant sub menus of the Advanced Configuration menu.

The Basic Configuration menu enables to access the following parameter sets:

### 4.2.4.1.1 IP Parameters

- IP Address
- Subnet Mask
- Default Gateway Address
- DHCP Client
  - ◇ DHCP Option
  - ◇ Access to DHCP

Refer to section [4.2.6.1](#) for a description of these parameters.

### 4.2.4.1.2 Performance Parameters

- Maximum Modulation Level (SU)

Refer to section [4.2.6.5](#) for a description of these parameters.

### 4.2.4.1.3 Network Management Parameters

- Wi2 IP Address (SU)

Refer to section [4.2.6.3.8](#) for a description of this parameter.

### 4.2.4.1.4 Air Interface Parameters

- ESSID
- Operator ESSID Parameters (AU)

- ◇ Operator ESSID Option
- ◇ Operator ESSID
- Frequency Definition
  - ◇ Select Sub-Band (AU, if more than one is available)
  - ◇ Frequency (AU)
  - ◇ User Defined Frequency Subsets (SU)
- Best AU Parameters (SU)
  - ◇ Best AU Support
  - ◇ Preferred AU MAC Address
- Cell Distance Parameters (AU)
  - ◇ Cell Distance Mode
  - ◇ Maximum Cell Distance
  - ◇ Fairness Factor
  - ◇ Per SU Distance Learning
- ATPC Parameters
  - ◇ ATPC Option
- Transmit Power
- Maximum Tx Power (SU)
- Tx Control (AU)
- Antenna Gain

Refer to section [4.2.6.2](#) for a description of these parameters.

#### 4.2.4.1.5 Country Code Parameters

- Country Code Select

- Re-apply Country Code Values

Refer to section 4.2.6.8 for a description of these parameters.

#### 4.2.4.1.6 Bridge Parameters

- VLAN Support
  - ◇ VLAN ID – Management

Refer to section [4.2.6.4](#) for a description of these parameters.

#### 4.2.4.1.7 Security Parameters

- Authentication Algorithm
- Data Encryption Option
- Security Mode
- Default Multicast Key (AU)
- Default Key (SU)
- Key 1 to Key 4
- Promiscuous Authentication (AU)

Some or all of the security parameters may not be available in units that do not support the applicable features. Refer to section [4.2.6.7](#) for a description of these parameters.

### 4.2.5 Site Survey Menu

The Site Survey menu displays the results of various tests and counters for verifying the quality of the wireless link. These tests can be used to help determine where to position the units for optimal coverage, antenna alignment and troubleshooting. The counters can serve for evaluating performance and identifying potential problems. In the AU, there is also an extensive database for all SUs served by it.

The Site Survey menu includes the following options:

- Traffic Statistics
- Ping Test

- Continuous Link Quality display (SU only)
- MAC Address Database
- Continuous Noise Floor Display (AU only)
- Per Modulation Level Counters
- Link Capability

## 4.2.5.1 Traffic Statistics

The traffic statistics are used to monitor, interpret and analyze the performance of the wired and wireless links. The counters display statistics relating to wireless link and Ethernet frames. The Traffic Statistics menu includes the following options:

- **Display Counters:** Select this option to display the current value of the Ethernet and wireless link (WLAN) counters.
- **Reset Counters:** Select this option to reset the counters.

### 4.2.5.1.1 Ethernet Counters

The unit receives Ethernet frames from its Ethernet port and forwards the frames to its internal bridge, which determines whether each frame should be transmitted to the wireless medium. Frames discarded by the unit's hardware filter are not counted by the Ethernet counters. For units with HW revision B and lower, the maximum length of a regular IEEE 802.1 Ethernet packet that can be accepted from or transmitted to the Ethernet port is 1514 bytes, excluding CRC and VLAN(s). For units with HW revision C and higher, the maximum length of an Ethernet packet that can be accepted from or transmitted to the Ethernet port (excluding CRC) is 1600 bytes, including VLAN(s) for single or double-tagged packets.

The unit transmits valid data frames received from the wireless medium to the Ethernet port, as well as internally generated frames, such as responses to management queries and pings received via the Ethernet port.

The Ethernet Counters include the following statistics:

- **Total received frames via Ethernet:** The total number of frames received from the Ethernet port. This counter includes both invalid frames (with errors) and valid frames (without errors).

- **Transmitted wireless to Ethernet:** The number of frames transmitted by the unit to the Ethernet port. These are generally frames received from the wireless side, but also include frames generated by the unit itself.

#### 4.2.5.1.2 WLAN Counters

The unit submits data frames received from the Ethernet port to the internal bridge, as well as self generated control and wireless management frames. After a unicast data frame is transmitted, the unit waits for an acknowledgement (ACK) message from the receiving unit. Some control and wireless management frames, as well as broadcast and multicast frames sent to more than one unit, are not acknowledged. If an ACK is not received after a predefined time, which is determined by the **Maximum Cell distance** parameter, the unit retransmits the frame until an ACK is received. If an ACK is not received before the number of retransmissions has reached a maximum predefined number, which is determined by the **Number of HW Retries** parameter, the frame is dropped.

Each packet to be transmitted to the wireless link is transferred to one of three queues: Low, Medium and High. Packets in the High queue have the highest priority for transmission, and those in the Low queue have the lowest priority. The packets in the High queue will be transmitted first. When this queue is emptied, the packets in the Medium queue will be sent. Finally, when both the High and Medium queues are empty, the packets in the Low queue will be sent.

Data packets are routed to either the High or Low queue, according to the queue selected for them before the MIR/CIR mechanism (for more information see section [4.2.6.6.3](#)).

Broadcasts/multicasts are routed to the Medium queue (applicable only for AU).

Control and wireless management frames generated in the unit are routed to the High queue.

Any frame coming from the Ethernet port, which is meant to reach another BreezeACCESS VL unit via the wireless port (as opposed to messages intended for stations behind other BreezeACCESS VL units), is sent to the High queue, regardless of the priority configuration.

The Wireless Link Counters include the following statistics:

- **Total transmitted frames to wireless:** The number of frames transmitted to the wireless medium. The total includes one count for each successfully transmitted unicast frame (excluding retransmissions), and the number of transmitted multicast and broadcast frames, including control and wireless management frames. In the AU, there are also separate counters for the following:

- ◇ Beacons (AU only)

- ◇ Management and Other Data frames, including successfully transmitted unicast frames and multicast/broadcast data frames (excluding retransmissions, excluding Beacons in AU)
- **Total Transmitted Unicasts** (AU only): The number of unicast frames successfully transmitted to the wireless medium, excluding retransmissions. This count is useful for calculating the rates of retransmissions or dropped frames, as only unicast frames are retransmitted if not acknowledged.
- **Total submitted frames (bridge)**: The total number of data frames submitted to the internal bridge for transmission to the wireless medium. The count does not include control and wireless management frames, or retransmissions. There are also separate counts for each priority queue through which the frames were routed (High, Mid and Low).
- **Frames dropped (too many retries)**: The number of dropped frames, which are unsuccessfully retransmitted without being acknowledged until the maximum permitted number of retransmissions. This count includes dropped data frames as well as dropped control and wireless management frames.
- **Total retransmitted frames**: The total number of retransmissions, including all unsuccessful transmissions and retransmissions.
- **Total transmitted concatenated frames**: The total number of concatenated frames transmitted successfully to the wireless medium, excluding retransmissions. There are also separate counts for concatenated frames that include one frame (Single), two frames (Double) or more than two frames (More). For more details refer to section [4.2.6.5.9](#).
- **Total Tx events**: The total number of transmit events. Typically, transmission events include cases where transmission of a frame was delayed or was aborted before completion. The following additional counters are displayed to indicate the reason for and the nature of the event:
  - ◇ Dropped: The number of dropped frames, which are unsuccessfully retransmitted without being acknowledged until the maximum permitted number of retransmissions.
  - ◇ Underrun: The number of times that transmission of a frame was aborted because the rate of submitting frames for transmission exceeds the available transmission capability.
  - ◇ Others: The number of frames whose transmission was not completed or delayed due to a problem other than those represented by the other counters.

- **Total received frames from wireless:** The total number of frames received from the wireless medium. The count includes data frames as well as control and wireless management frames. The count does not include bad frames and duplicate frames. For a description of these frames, refer to Bad frames received and Duplicate frames discarded below.
- **Total received data frames:** The total number of data frames received from the wireless medium, including duplicate frames. Refer to Duplicate frames discarded below.
- **Total Rx events:** The total number of frames that were not received properly. The following additional counters are displayed to indicate the reason for the failure:
  - ◇ Phy: The number of Phy errors (unidentified signals).
  - ◇ CRC: The number of frames received from the wireless medium containing CRC errors.
  - ◇ Overrun: The number of frames that were discarded because the receive rate exceeded the processing capability or the capacity of the Ethernet port.
  - ◇ Decrypt: The number of frames that were not received properly due to a problem in the data decryption mechanism.
  - ◇ Other
- **Total received concatenated frames:** The total number of concatenated frames received from the wireless medium, including duplicate frames. There are also separate counts for concatenated frames that include one frame (Single), two frames (Double) or more than two frames (More). For more details refer to section [4.2.6.5.9](#).
- **Bad fragments received:** The number of fragments received from the wireless medium containing CRC errors.
- **Duplicate frames discarded:** The number of data frames discarded because multiple copies were received. If an acknowledgement message is not received by the originating unit, the same data frame can be received more than once. Although duplicate frames are included in all counters that include data frames, only the first copy is forwarded to the Ethernet port.

- **Internally discarded MIR\CIR:** The number of data frames received from the Ethernet port that were discarded by the MIR/CIR mechanism to avoid exceeding the maximum permitted information rate.

### 4.2.5.2 Ping Test

The *Ping Test* submenu is used to control ping from the unit and includes the following options:

- **Destination IP Address:** The destination IP address of the device being pinged. The default IP address is 192.0.0.1.
- **Number of Pings to Send:** The number of ping attempts per session. The available range is from 0 to 9999. The default value is **1**. Select 0 for continuous pinging.
- **Ping Frame Length:** The ping packet size. The available range is from 60 to 1472 bytes. The default value is 64 bytes.
- **Ping Frame Timeout:** The ping frame timeout, which is the amount of time (in ms) between ping attempts. The available range is from 100 to 60,000 ms. The default value is 200 ms.
- **Start Sending:** Starts the transmission of ping frames.
- **Stop Sending:** Stops the transmission of ping frames. The test is automatically ended when the number of pings has reached the value specified in the **No. of Pings** parameter, described above. The **Stop Sending** option can be used to end the test before completing the specified number of pings, or if continuous pinging is selected.
- **Show Ping Test Values:** Displays the current values of the ping test parameters, the transmission status, which means whether it is currently sending or not sending pings, the number of pings sent, and the number of pings received, which means the number of acknowledged frames.

### 4.2.5.3 Link Quality (SU only)

The Link Quality submenu enables viewing continuously updated information on the quality of the wireless link. The Link quality submenu includes the following options:

#### 4.2.5.3.1 Continuous Average SNR/RSSI Display

The **Continuous Average SNR Display** option displays continuously updated information regarding the average quality of the received signal, using Signal to Noise Ratio (SNR) and Received Signal Strength Indication (RSSI) measurements.

The average RSSI is calculated using the formula:

$\text{NewAvgRSSI} = (\text{PrevAvgRSSI} \times \text{HistWeight}) + \text{CrtRSSI} \times (1 - \text{HistWeight})$ , where:

- $\text{NewAvgRSSI}$  = New Average RSSI
- $\text{PrevAvgRSSI}$  = Previous Average RSSI
- $\text{CrtRSSI}$  = RSSI of the current packet
- $\text{HistWeight}$  = History Weight

The History Weight is given by the next formula:

$\text{HistWeight} = 0.9 / ( \text{PastTime} / 2^{\text{SNR\_Memory\_Factor}} + 1 )$ , where

$\text{PastTime}$  = time between the current packet and previous packet, in seconds

$\text{SNR\_Memory\_Factor}$  = the Average SNR Memory Factor configurable parameter (see Average SNR Memory Factor on page 186).

The  $\text{SNR\_Memory\_Factor}$  can be -1 in this case the history is not used and the Average RSSI is the RSSI of the current packet.

The same formula is used also for calculating Average SNR (SNR values are used instead of RSSI values).

Click the **Esc** key to abort the test.

#### 4.2.5.3.2 Continuous Noise Floor Display

The **Continuous Noise Floor Display** option displays continuously updated information regarding the average noise floor in the wireless link.

Click the **Esc** key to abort the test.

#### 4.2.5.3.3 Continuous UpLink Quality Indicator Display

The **Continuous UpLink Quality Indicator Display** option displays continuously updated information regarding the average quality of the wireless link to the AU, using the dynamically updated average modulation level measurements. The Link Quality Indicator (LQI) calculation is performed using the formula:

$\text{LQI} = (0.9 \times \text{"Previous LQI"}) + (0.1 \times \text{"Last Successful Modulation Level"})$ .

Each successful transmit will be included in this average, by using the modulation level in which the frame was successfully transmitted as the “Last Successful Modulation Level”.

In order to receive quick and reliable LQI measurements, there should be sufficient traffic between the SU and the AU. It is recommended to have traffic of at least 100 packets per second. The traffic can be generated either by an external utility (FTP session, ping generator, etc.) or by the Ping Test option in the Site Survey menu with the appropriate settings (see section [4.2.5.2](#)).



#### NOTE

If Limited Test is indicated next to the LQI results, it means that the results may not indicate the true quality, as not all modulation levels from 1 to 8 are available. The limitation may be due to the HW of the unit (HW Revision A), or the applicable parameters in the country code, or the configurable Maximum Modulation Level parameter.

Click the **Esc** key to abort the test.

## 4.2.5.4 MAC Address Database

### 4.2.5.4.1 MAC Address Database in AU

The **MAC Address Database** option in the AU displays information regarding the Subscriber Units associated with the AU, as well as bridging (forwarding) information. When DRAP is supported, it enables viewing details on the active Gateways in the sector. The following options are available:

- **Display Bridging and Association Info:** The Display Bridging and Association Info option displays a list of all the Subscriber Units and stations in the AU's Forwarding Database. For stations behind an SU, the SU's MAC address is also displayed (SU Address).

Each MAC address entry is followed by a description, which may include the following:

- ◇ **Et (Ethernet):** An address learned from the Ethernet port.
- ◇ **Vp (Virtual port):** An address of a node behind an associated SU. For these addresses, learned from the wireless port, the address of the applicable SU is also displayed (in parenthesis).
- ◇ **St (Static):** An associated SU. For these entries, the following details are also displayed for each SU: Unit Name, SW version, Unit Type, Distance from the AU, IP Address, Wi2 IP Address as defined in the SU (or 0.0.0.0 for none), ESSID.
- ◇ **X:** An SU that is included in the Deny List.

- ◇ **Sp (Special):** 3 addresses that are always present, including:
  - The MAC address of the AU.
  - Alvarion's Multicast address (01-20-D6-00-00-01). The system treats this address as a Broadcast address.
  - The Ethernet Broadcast address (FF-FF-FF-FF-FF-FF).

In addition, a summary table displays information about the Forwarding Database (Bridging Info) and the Associated Subscriber Units Database (Association Info). Each database includes the following information:

- ◇ The current number of entries. For Bridging Info this includes the **Et** (Ethernet) and the **Vp** (Virtual ports) entries. For Association Info this is the number of the currently associated SUs.

#### NOTE



An SU is only removed from the list of associated SUs under the following conditions:

- The SU failed to respond to 100 consecutive data frames transmitted by the AU and is considered to have "aged out".
- During the last 6 minutes (or more) the SU did not transmit any data frame, and failed to respond to certain frames that typically are transmitted by the AU every 10 seconds. Since the sampling interval for this state is about 10 minutes, it means that the decision to remove the SU from the Associations Database will take place between 6 to 16 minutes from the time the SU ceased sending data or responding to these "keep-alive" frames (for AUS the sampling interval is 1 minute, meaning decision time of 6 to 7 minutes).
- ◇ The aging time specified for entries in these tables. The aging time for Bridging Info is as specified by the **Bridge Aging Time** parameter. The default is 300 seconds. There is no aging time for Association Info entries.
- ◇ The maximum number of entries permitted for these tables, which is 1021 (1024 minus the number of special Sp addresses as defined above) for Bridging Info and as specified by the **Maximum Number of Associations** parameter for Association Info. The default value of the Maximum Number of Associations parameter is 512.
- **Display Association Info:** Displays information regarding the Subscriber Units associated with the AU. Each list entry includes the following information:
  - ◇ The MAC Address of the associated Subscriber Unit
  - ◇ Age in seconds, indicating the elapsed time since receiving the last packet from the Subscriber Unit.

- ◇ The value configured for the Maximum Modulation Level parameter of the Subscriber Unit
- ◇ The Status of the Subscriber Unit. There are three options:
  - 1 Associated
  - 2 Authenticated
  - 3 Not Authenticated (a temporary status)

The various status states are described below (this is a simplified description of the association process without the effects of the Best AU algorithm).

<b>Table 4-4: Authentication and Association Process</b>		
<b>Message</b>	<b>Direction</b>	<b>Status in AU</b>
SU Status: Scanning		
A Beacon with correct ESSID	AU → SU	-
SU Status: Synchronized		
Authentication Request	SU → AU	Not authenticated
Authentication Successful	AU → SU	Authenticated
SU Status: Authenticated		
Association Request	SU → AU	Authenticated
Association Successful	AU → SU	Associated
SU Status: Associated		
ACK	SU → AU	Associated
Data Traffic	SU ↔ AU	Associated

- ◇ The SNR of the SU measured at the AU
- ◇ The RSSI of the SU measured at the AU
- ◇ The Unit Name of the SU.
- ◇ The SW version of the SU.
- ◇ The Unit Type of the SU.

- ◇ Distance from the AU.
- ◇ IP Address
- ◇ Wi2 IP Address as defined in the SU (or 0.0.0.0 for none)
- ◇ The ESSID of the SU

In addition, a summary table displays information about the Forwarding Database (Bridging Info). The database includes the following information:

- ◇ The current number of entries. This is the number of currently associated SUs.

#### NOTE



An SU is only removed from the list of associated SUs under the following conditions:

- The SU failed to respond to 100 consecutive data frames transmitted by the AU and is considered to have "aged out".
- During the last 6 minutes (or more) the SU did not transmit any data frame, and failed to respond to certain frames that typically are transmitted by the AU every 10 seconds. Since the sampling interval for this state is about 10 minutes, it means that the decision to remove the SU from the Associations Database will take place between 6 to 16 minutes from the time the SU ceased sending data or responding to these "keep-alive" frames (for AUS the sampling interval is 1 minute, meaning decision time of 6 to 7 minutes).
- ◇ The aging time specified for entries in these table. There is no aging time for Association Info entries.
- ◇ The maximum number of entries permitted for this table, which is specified by the **Maximum Number of Associations** parameter. The default value of the **Maximum Number of Associations** parameter is 512.
- **Show MIR/CIR Database:** Displays information on the MIR/CIR support for associated Subscriber Units.

Each entry includes the following information:

- ◇ The MAC address of the associated Subscriber Unit
- ◇ The values of the MIR and CIR parameters configured in the applicable SU for the downlink (AU to SU) and for the uplink (SU to AU).
- ◇ The value configured in the applicable SU for the Maximum Delay parameter.

- ◇ The Unit Name of the SU.
- ◇ The SW version of the SU.
- ◇ The Unit Type of the SU.
- ◇ IP Address

■ **Display MAC Pinpoint Table:** The MAC Pinpoint table provides for each of the Ethernet stations (identified by the MAC Address) connected to either the AU or to any of the SUs served by it, the identity (MAC Address) of the wireless device to which they are connected.

■ **Gateways Table:** When the DRAP option is supported, the Gateways Table provides details on the active Gateways connected to any of the SUs served by the AU. For each Gateway, the displayed information includes:

- ◇ Gateway Type (VG-1D1V, VG-1D2V, NG-4D1W)
- ◇ IP Address
- ◇ Number of Voice Calls (applicable only to Voice Gateways)

#### 4.2.5.4.2 MAC Address Database in SU

The **MAC Address Database** option in the SU displays information regarding the Subscriber Units bridging (forwarding) information. The following option is available:

■ **Display Bridging and Association Info:** The Display Bridging and Association Info option displays a list of all the stations in the SU's Forwarding Database.

Each MAC address entry is followed by a description, which may include the following:

- ◇ **Et (Ethernet):** An address learned from the Ethernet port.
- ◇ **St (Static):** The associated AU.
- ◇ **Wl (Wireless):** An address of a node behind the associated AU, learned via the wireless port.
- ◇ **Sp (Special):** 4 addresses that are always present, including:

- The MAC address of the SU.
- Alvarion's Multicast address (01-20-D6-00-00-01). The system treats this address as a Broadcast address.
- Alvarion's special Multicast address (01-20-D6-00-00-05), reserved for future use.
- The Ethernet Broadcast address (FF-FF-FF-FF-FF-FF).

In addition, a summary table displays information about the Forwarding Database (Bridging Info). The summary table includes the current number of entries, the aging time specified by the Bridge Aging Time parameter and the maximum number of entries permitted for this table, which is 1020.

#### 4.2.5.5 Continuous Noise Floor Display (AU only)

The **Continuous Noise Floor Display** option displays continuously updated information regarding the average noise floor in the wireless link.

Click the **Esc** key to abort the test.

#### 4.2.5.6 Per Modulation Level Counters

The Per Modulation Level Counters display statistics relating to wireless link performance at different radio modulation levels. The Per Modulation Level Counters menu includes the following options:

- **Display Counters:** Select this option to display the current values of the Per Modulation Level Counters.
- **Reset Counters:** Select this option to reset the Per Modulation Level Counters.

The statistics show the number of frames accumulated in different categories since the last reset.

For SUs, the Per Modulation Level Counters display the following information for each modulation level supported by the unit:

- **SUCCESS:** The total number of successfully transmitted unicasts at the applicable modulation level.
- **FAILED:** The total number of failures to successfully transmit unicast frame during a HW Retry cycle at the applicable modulation level.

In addition, the **Average Modulation Level (AML)** is also displayed. This is the average modulation level (rounded to the nearest integer) since the last time the

Per Modulation Level counters were reset. The average is calculated using the **SUCCESS** count at each modulation level as weights.

For AUs, the **SUCCESS** and **FAILED** counts are provided for each of the associated SUs, which are identified by their MAC address.

### 4.2.5.7 Link Capability

The Link Capability option provides information on HW and SW capabilities of relevant units. In an AU, the information provided in the Link Capability reports is for all associated SUs. In an SU, the Link Capability reports include information on all AUs in the neighboring AUs table (all AUs with whom the SU can communicate).

The Link Capability feature enables to adapt the configuration of the unit according to the capabilities of other relevant unit(s) to ensure optimal operation.

The Link Capability submenu includes the following options:

#### 4.2.5.7.1 Show Link Capability-General

Select this option to view information on general parameters of relevant units. For each relevant unit, identified by its MAC address, the following details are displayed:

- **HwVer:** the hardware version of the unit.
- **CpldVer:** The version of the Complex Programmable Logic Device (CPLD) used in the unit. This parameter is available only in AUs, displaying the CPLD version in the relevant SU.
- **Country:** The 3 or 4 digits country code supported by the unit.
- **SwVer:** The SW version used by the unit. This parameter is available only in SUs, displaying the SW version in the relevant AU.
- **BootVer:** The Boot Version of the unit. This parameter is available only in AUs, displaying the Boot version in the relevant SU.

#### 4.2.5.7.2 Show Link Capability-Wireless Link Configuration

Select this option to view information on current wireless link parameters of relevant units. For each relevant unit, identified by its MAC address, the following details are displayed:

- **ATPC Option:** Enable or Disable.
- **Adaptive Modulation Option:** Enable or Disable.

- **Burst Mode Option:** Enable or Disable.
- **DFS Option:** Enable or Disable. This parameter is available only in SUs, displaying the current option in the relevant AU.
- **Concatenation Option:** Enable or Disable.
- **Country Code Learning by SU:** Enable or Disable. This parameter is available only in SUs, displaying the current option in the relevant AU.
- **Per SU Distance Learning:** Enable or Disable. This parameter is available only in SUs, displaying the current option in the relevant AU.

#### 4.2.5.7.3 Show Link Capability-Security Configuration

Select this option to view information on current security related parameters of relevant units. For each relevant unit, identified by its MAC address, the following details are displayed:

- **Security Mode:** WEP, AES OCB or FIPS 197.
- **Authentication Algorithm:** Shared Key or Open System.
- **Data Encryption Option:** Enable or Disable.

#### 4.2.5.7.4 Show Link Capability by AU (SU only)

Select this option to view all capabilities information (General, wireless Link Configuration, Security Configuration) of a selected AU (by its MAC address).

#### 4.2.5.7.5 Show Link Capability by SU (AU only)

Select this option to view all capabilities information (General, Wireless Link Configuration, Security Configuration) of a selected SU (by its MAC address).

## 4.2.6 Advanced Configuration Menu

The Advanced Configuration menu provides access to all parameters, including the parameters available through the Basic Configuration menu.

The Advanced Configuration menu enables accessing the following menus:

- IP Parameters
- Air Interface Parameters
- Network Management Parameters
- Bridge Parameters
- Performance Parameters
- Service Parameters
- Security Parameters

### 4.2.6.1 IP Parameters

The IP Parameters menu enables defining IP parameters for the selected unit and determining its method of IP parameter acquisition.

The IP Parameters menu includes the following options:

- IP Address
- Subnet Mask
- Default Gateway Address
- DHCP Client

#### 4.2.6.1.1 IP Address

The IP Address parameter defines the IP address of the unit.

The default IP address is 10.0.0.1.

#### 4.2.6.1.2 Subnet Mask

The Subnet Mask parameter defines the subnet mask for the IP address of the unit.

The default mask is 255.0.0.0.

### 4.2.6.1.3 Default Gateway Address

The Default Gateway Address parameter defines the IP address of the unit's default gateway.

The default value for the default gateway address is 0.0.0.0.

### 4.2.6.1.4 DHCP Client

The DHCP Client submenu includes parameters that define the method of IP parameters acquisition.

The DHCP Client submenu includes the following options:

- DHCP Option
- Access to DHCP

#### 4.2.6.1.4.1 DHCP Option

The DHCP Option displays the current status of the DHCP support, and allows selecting a new operation mode. Select from the following options:

- Select **Disable** to configure the IP parameters manually. If this option is selected, configure the static IP parameters as described above.
- Select **DHCP Only** to cause the unit to search for and acquire its IP parameters, including the IP address, subnet mask and default gateway, from a DHCP (Dynamic Host Configuration Protocol) server only. If this option is selected, you must select the port(s) through which the unit searches for and communicates with the DHCP server, as described in section [4.2.6.1.4.2](#). You do not have to configure static IP parameters for the unit. DHCP messages are handled by the units as management frames.
- Select **Automatic** to cause the unit to search for a DHCP server and acquire its IP parameters from the server. If a DHCP server is not located within approximately 40 seconds, the currently configured parameters are used. If this option is selected, you must configure the static IP parameters as described above. In addition, you must select the port(s) through which the unit searches for and communicates with the DHCP server, as described in section [4.2.6.1.4.2](#).

The default is Disable.

#### 4.2.6.1.4.2 Access to DHCP

The Access to DHCP option enables defining the port through which the unit searches for and communicates with a DHCP server. Select from the following options:

- From Wireless Link Only
- From Ethernet Only
- From Both Ethernet and Wireless Link

The default for Access Units is From Ethernet Only. The default for Subscriber Units is From Wireless Link Only.

#### 4.2.6.1.5 Show IP Parameters

The Show IP Parameters option displays the current values of the IP parameters, including the **Run Time IP Address**, **Run Time Subnet Mask** and **Run Time Default Gateway Address**.

### 4.2.6.2 Air Interface Parameters

The Air Interface Parameters menu enables viewing the current Air Interface parameters defined for the unit and configuring new values for each of the relevant parameters.

#### 4.2.6.2.1 Country Code and Sub-Bands

Each country has its own regulations regarding operation modes and parameters such as allowable frequencies and bandwidth, the need to employ an automatic mechanism for detection and avoidance of frequencies used by radar systems, maximum transmit power at each of the supported modulation levels and the ability to use burst transmissions. To efficiently manage these country dependent parameters, each unit has a 'Country Code' parameter and a set of accompanying parameters, which depend on this country code. Where more than one set of parameters can be used, the available sets are defined as Sub-Bands, selectable through the Frequency configuration menu.

#### 4.2.6.2.2 ESSID Parameters

The ESSID (Extended Service Set ID) is a string used to identify a wireless network and to prevent the unintentional merging of two wireless networks or two sectors in the same network. Typically, a different ESSID is defined for each AU. To facilitate easy addition of SUs to an existing network without a prior knowledge of which specific AU will serve it, and to support the Best AU feature, a secondary "global" ESSID, namely "Operator ESSID", can be configured in the AU. If the Operator ESSID Option is enabled at the AU, the Beacon frames transmitted by it will include both the ESSID and Operator ESSID. The SU shall

regard such frames if either the ESSID or the Operator ESSID matches its own ESSID. The ESSID of the AU with which the SU is eventually associated is defined as the Run-Time ESSID of the SU. Typically, the initial ESSID of the SU is configured to the value of the Operator ESSID. When the SU has become associated with a specific AU, its ESSID can be reconfigured to the value of the ESSID of the AU.

#### 4.2.6.2.2.1 ESSID

The ESSID parameter defines the ESSID of the unit.

Valid values: A string of up to 31 printable ASCII characters.

The default value is ESSID1.



#### NOTE

The ESSID string is case sensitive.

#### 4.2.6.2.2.2 Operator ESSID Parameters (AU only)

The Operator ESSID Parameters submenu includes the following parameters:

##### 4.2.6.2.2.2.1 Operator ESSID Option

The Operator ESSID Option enables or disables the use of Operator ESSID for establishing association with SUs.

The default is Enable.

##### 4.2.6.2.2.2.2 Operator ESSID

The Operator ESSID parameter defines the Operator ESSID.

Valid values: A string of up to 31 printable ASCII characters.

The default value is ESSID1.



#### NOTE

The Operator ESSID string is case sensitive.

#### 4.2.6.2.3 Frequency Definition Parameters

##### 4.2.6.2.3.1 Sub-Bands and Frequency Selection

Each unit is delivered with one or more pre-configured Sub-Bands, according to the country code. These sets of parameters include also the frequencies that can be used and the bandwidth.

The parameters that determine the frequency to be used are set in the AU. If more than one Sub-Band is available, the sub-band to be used can be selected. If only one Sub-Band is supported, then the sub-band selection option is not

available. The SU should be configured with a minimal set of parameters to ensure that it will be able to automatically detect and use the frequency/bandwidth used by the AU, including possible changes in this frequency (Automatic Sub Band Select feature).

To simplify the installation process the SU scans a definable frequencies subset after power-up. The defined frequencies subsets may include frequencies from more than one Sub-Band, enabling automatic detection of both frequency and bandwidth. If the Best AU feature is enabled, the SU will scan the defined subset and the operating frequency/bandwidth will be determined by the Best AU mechanism (including the optional use of the Preferred AU feature). Otherwise the SU will try to associate with the first AU it finds. If no AU is found, the SU will start another scanning cycle.

#### 4.2.6.2.3.2 Avoiding Frequencies with Radar Activity

In some regions, it is important to ensure that wireless access equipment does not interfere with certain radar systems in the 5 GHz band. If radar is being detected, the wireless access network should move automatically to a frequency that does not interfere with the radar system.

The country dependent set of parameters includes also an indication whether DFS (Dynamic Frequency Selection) should be used. The DFS algorithm is designed to detect and avoid operation in channels with radar activity. If the current sub-band does not support DFS, then the DFS parameters configuration submenu is not available.

When DFS is enabled, the AU monitors the spectrum continuously, searching for signals with a specific pattern indication radar activity. Upon detecting radar activity, the AU immediately stops transmitting on this frequency and starts looking for another radar-free frequency. The subset of viable frequencies is configurable.

The AU maintains a continuously updated database of all applicable frequencies, where each frequency is marked as Radar Free, Radar Detected or Adjacent to Radar. The AU attempts to check a new frequency only if it is marked as Radar Free. If a radar activity was detected on a certain frequency, it will be marked in the database as a Radar Detected frequency. The AU will not attempt to check for radar activity in frequencies marked as Radar Detected. A certain time after detecting radar activity on a frequency, it will be removed from the list of Radar Detected frequencies and will be marked as Radar Free. If radar activity was detected on a certain frequency, adjacent channels should not be used as well, according to the bandwidth. For instance, if the bandwidth is 20 MHz, then if radar activity was detected in 5800 MHz, frequencies 5790 MHz and 5810 MHz should not be used as well. These frequencies are marked in the database as Adjacent to Radar, and will be treated the same as Radar Detected frequencies.

Before ceasing transmission on the frequency where radar signals had been detected, the AU sends a special disassociation message to its associated SUs. This message includes an indication whether the SUs should wait for this AU. If the SUs should wait, the message includes also the waiting time. During this time each SU searches for the AU in the defined frequencies subset. If the AU was not found within the waiting time, or if a waiting request was not included in the message, the SU starts searching for any AU, using the Best AU mechanism if applicable.

Typically, operators prefer to preserve the original frequency planning and to avoid moving to a new channel unless they are sure that there is a continuous radar activity in the original channel. It should be noted that detection of radar activity does not necessarily indicate a continuous radar activity in the channel. A channel reuse algorithm enables returning to the original channel under certain conditions that indicates low radar activity on the channel.

#### 4.2.6.2.4 Frequency Definition Submenu in AU

The Frequency Definition submenu in AU includes the following parameters:

##### 4.2.6.2.4.1 Sub-Band Select

This parameter is available only if the country code supports two or more Sub-Bands. For information on how to view the Sub-Bands supported by the unit and the supported parameters' values and options, refer to section [4.2.2.4](#).

The range depends on the number of Sub-Bands supported by the country code.

The default selection is Sub-Band 1.

##### 4.2.6.2.4.2 Frequency

The Frequency parameter defines the transmit/receive frequency when DFS is not enabled. If DFS is enabled, it sets the initial operational frequency upon starting the DFS mechanism for the first time.

The range depends on the selected Sub-Band.

The default is the lowest frequency in the Sub-Band.

**NOTE 1** (Japan 4.9 GHz, 10 MHz Bandwidth):

In BreezeACCESS units operating in the 4.9 GHz Japan band (not B&B point-to-point) with a 10 MHz bandwidth, the following rules must be met for full compliance with regulations:

1. When operating at 4945 MHz, the Transmit Power parameter in the AU should not be set to a value above 11 dBm. The Maximum Transmit Power of the SU should not be set to a value above 10 dBm.

2. When operating at 5055 MHz, the Transmit Power parameter in the AU should not be set to a value above 13 dBm. The Maximum Transmit power of the SU should not be set to a value above 10 dBm.

This requirement, although not indicated in the certification document, is needed following the tests performed in the certification lab.

**NOTE 2** (FCC 5.3 GHZ, 10 MHz Bandwidth)

For full compliance with FCC regulation of units with HW rev C using a 10 MHz bandwidth, if you wish to include frequency channel 5265 MHz in the set of frequencies to be used, then the Transmit Power parameter in the AU, and the Maximum Tx Power parameter in the SUs, should not be set to a value above “25-Antenna Gain”. If there is a need to use a higher value for these parameters, this frequency should not be used.

**NOTE 3** (FCC 5.3 GHZ, 20 MHz Bandwidth)

For full compliance with FCC regulations, the following requirements should be followed in units using a 20 MHz bandwidth:

1. In units HW Revision B, if you wish to include frequency channel 5270 MHz in the set of frequencies to be used, then the Transmit Power parameter in the AU, and the Maximum Tx Power parameter in the SUs, should not be set to a value above “17-Antenna Gain”. If there is a need to use a higher value for these parameters, this frequency should not be used.
2. In units with HW Revision C, if you wish to include one or more of frequency channels 5270, 5275 and 5330 MHz in the set of frequencies to be used, then the Transmit Power parameter in the AU, and the Maximum Tx Power parameter in the SUs, should not be set to a value above “20-Antenna Gain”. If there is a need to use a higher value for these parameters, this frequency should not be used.

#### 4.2.6.2.4.3 DFS Parameters

The DFS Parameters submenu is available only if DFS is supported by the current Sub-Band. The DFS Parameters submenu includes the following parameters:

##### 4.2.6.2.4.3.1 DFS Required by Regulations

The DFS Required by Regulations option enables defining whether DFS should be used for compliance with applicable local regulations. The options are Yes or No. Selection of the No option will disable the radar detection and dynamic frequency selection mechanism.

The default is Yes.

#### 4.2.6.2.4.3.2 *Frequency Subset Definition*

The Frequency Subset Definition parameter defines the frequencies that will be used in the DFS mechanism. The available frequencies according to the Sub-Band are displayed, and each of the frequencies in the list is associated with an index. The frequencies subset can be defined by entering the indexes of the required frequencies, or “A” to select all available frequencies.

The default is the complete list of frequencies available in the Sub-Band.

#### 4.2.6.2.4.3.3 *Channel Check Time*

The Channel Check Time defines the time allocated for checking whether there is a radar activity on a new frequency after power up or after attempting to move to a new frequency upon detecting radar activity on the previously used frequency. During this time the AU does not transmit.

The range is 1 to 3600 seconds.

The default is 60 seconds.

#### 4.2.6.2.4.3.4 *Channel Avoidance Period*

The Channel Avoidance Period defines the time that the frequency will remain marked in the database as Radar Detected or Adjacent to Radar after detecting radar activity. These frequencies will not be used when searching for a new frequency. When this time has elapsed, the unit frequency’s marking will change to Radar Free.

The range is 1 to 60 minutes.

The default is 30 minutes.

#### 4.2.6.2.4.3.5 *SU Waiting Option*

The SU Waiting Option defines whether the disassociation message sent by the AU, after detecting radar activity on the current frequency, will include a message instructing the SU to search only for the AU before attempting to search for another AU. The message includes also the time period during which the SU should not search for any other AU. The waiting time is the Channel Check Time plus 5 seconds.

The default is Enable.

#### 4.2.6.2.4.3.6 *Minimum Pulses to Detect*

The Minimum Pulses to Detect parameter defines the minimum number of radar pulses that should be detected before reaching a decision that radar is active on the channel.

The range is from 1 to 100 pulses.

The default is 4 pulses for FCC Country Codes, 8 for other (ETSI) Country Codes.

#### 4.2.6.2.4.3.7 Clear Radar Detected Channels After Reset

When the Clear Radar Detected Channels After Reset is enabled, after the next reset all viable frequencies will be marked in the database as Radar Free, including frequencies previously marked as either Radar Detected or Adjacent to Radar. In addition, the AU will start operation using its default frequency.

The default is Disable.

#### 4.2.6.2.4.4 Channel Reuse Parameters (DFS+)

The Channel Reuse algorithm enables returning to the original channel under certain conditions that indicate low radar activity on the original channel. The conditions are that radar was detected in this channel not more than N times (Maximum Number of Detections in Assessment Period) during the last T hours (Radar Activity Assessment Period). When the Channel Reuse Option is enabled, then by the end of the Channel Avoidance Period the unit will attempt returning to the original frequency, provided these conditions are met.

The Channel Reuse Parameters submenu includes the following options:

- **Channel Reuse Option:** Enabling/disabling the Channel Reuse algorithm.

The default is Disable.

- **Radar Activity Assessment Period:** The period in hours used for assessment of radar activity in the original channel.

The range is 1 to 12 hours.

The default is 5 hours.

- **Maximum Number of Detections in Assessment Period:** The maximum number of radar detections in the original channel during the Radar Activity Assessment Period that is required for reaching a decision to try again the original channel.

The range is 1 to 10 radar detections.

The default is 5 radar detections.

#### 4.2.6.2.4.4.1 Show DFS Settings And Data

Upon selecting the Show DFS Settings and Data, the values of all DFS parameters and the current operating frequency will be displayed. The current defined frequency subset as well as the defined subset (to be used after the next reset) are also displayed. In addition, all the applicable frequencies will be displayed together with their status in the database (Radar Free, Radar Detected or Adjacent to Radar).

#### 4.2.6.2.4.5 Country Code Learning by SU

This feature support simplified installation and updates processes by enabling the SU to adapt the Country Code used by the AU.

The AU advertises its country code in every beacon and association response message. Upon synchronization the SU will check if its country code and the country code received from the AU are the same. If they are not the same and the Country Code Learning by SU is enabled, the SU will use the AU's country code: the country code derived limitations will be forced and the following parameters will be set according to new country definitions:

- Maximum TX Power will be set to the maximum defined by the country code.
- TX Power will be set to the maximum defined by the country code.
- The Modulation Level will be set to the maximum modulation level defined by the country code.
- The Multicast Modulation Level will be set to the minimum modulation level defined by the country code.
- The Burst Mode will be set to enable if the country code supports burst mode, and the burst duration will be set to default.

The SU will learn a new Country Code only if it is running from the Main version. After country code learning (adaptation) the unit is automatically reset..

The default is Disable.

#### NOTE



The Country Code Learning by SU feature does not function with the default ESSID (ESSID1).

#### 4.2.6.2.4.6 Show Frequency definitions

Upon selecting Show Frequency Definitions, the selected Sub-Band and Frequency are displayed. In addition, all the parameters displayed upon selecting Show DFS Settings and Data are also displayed.

#### 4.2.6.2.5 Frequency Definition Submenu in SU

##### 4.2.6.2.5.1 Sub-Band Select

This parameter is available only if the country code supports two or more Sub-Bands. The Sub-Band Select option in the SU enables defining the sub band to be used during Spectrum Analysis (see Spectrum Analysis on page 150). It has no affect on the frequencies to be used during regular operation, which are defined using the User Defined Frequency Subsets menu described below. For

information on how to view the Sub-Bands supported by the unit and the supported parameters' values and options, refer to section [4.2.2.4](#).

The range depends on the number of Sub-Bands supported by the country code.

The default selection is Sub-Band 1

#### 4.2.6.2.5.2 User Defined Frequency Subsets

The User Defined Frequency Subsets menu enables defining for each of the available Sub-Bands the frequencies that will be used by the SU when scanning for an AU. For each available Sub-Band, the available frequencies are displayed, and an index is associated with each frequency. Enter either the desired frequency indexes, 'A' (All) for using all frequencies in the subset or 'N' (None) for not scanning that sub-band.

The default is all frequencies in all available sub-bands.

#### 4.2.6.2.5.3 Show Frequency Definitions

Upon selecting the Show Frequency Definitions, the selected frequencies in the available Sub-Bands and the current operating frequency are displayed.

#### 4.2.6.2.6 Best AU Parameters (SU)

An SU that can communicate with more than one AU using the same ESSID may become associated with the first AU it "finds", not necessarily the best choice in terms of quality of communication. The same limitation also exists if only one AU in the neighborhood has an ESSID identical to the one used by the SU, as it is not always necessarily the best choice.

The topology of a fixed access network is constantly changing. Changes in base station deployment and subscriber density can accumulate to create substantial changes in SU performance. The quest for load sharing together with the desire to create best throughput conditions for the SU created the need for the Best AU feature, to enable an SU to connect to the best AU in its neighborhood.

When the Best AU feature is used, each of the AUs is given a quality mark based on the level at which it is received by the SU. The SU scans for a configured number of cycles, gathering information from all the AUs with which it can communicate. At the end of the scanning period, the SU reaches a Best AU decision according to the information gathered. The AU with the highest quality mark is selected as the Best AU, and the SU will immediately try to associate with it. The quality mark given to each AU depends on the level at which it is received by the SU.

The Best AU selection mechanism can be overridden by defining a specific AU as the preferred AU.

**NOTE**

Although the SU selects the Best AU based on long-term conditions prior to the decision time, it may not always be connected to the instantaneous Best AU at any given time. Note also that the decision is made only once during the scanning interval. The decision may not remain the optimal one for ever. If there are significant changes in deployment of neighboring AUs and the SUs served by them, overall performance may be improved if the applicable SUs are reset intentionally so as to re-initiate the Best AU decision process.

The Best AU Parameters menu includes the following options:

#### 4.2.6.2.6.1 Best AU Support

The Best AU Support option enables or disables the Best AU selection feature.

The default is Disable.

**NOTE**

If the Best AU feature is not used, the SU associates with the first AU it finds whose ESSID or Operator ESSID is identical to its own ESSID.

#### 4.2.6.2.6.2 Number Of Scanning Attempts

When the Best AU option is enabled, the SU gathers information on neighboring AUs for approximately 2 seconds on each of the scanned frequencies. The Number of Scanning Attempts parameter defines the number of times that the process will be repeated for all relevant frequencies. A higher number may result in a better decision at the cost of an increased scanning time during which the SU is not operational.

Valid values: 1 - 255.

Default value: 4.

#### 4.2.6.2.6.3 Preferred AU MAC Address

The Preferred AU MAC Address parameter defines a specific AU with which the SU should associate. Gaining control of the SUs association is a powerful tool in network management. The Preferred AU MAC Address parameter is intended for applications where there is a need to dictate the preferred AU with which the SU should associate. To prevent the SU from associating with the first viable AU it finds, the Best AU Support mechanism should be enabled. Once the SU has identified the preferred AU based on its MAC address, it will associate with it and terminate the scanning process. If the preferred AU is not found, the SU will associate with an AU according to the decision reached using the best AU algorithm.

Valid values: A MAC address string.

The default value for the Preferred AU MAC Address is 00-00-00-00-00-00 (12 zeros), meaning that there is no preferred AU.

#### 4.2.6.2.6.4 Show Best AU Parameters and Data

The Show Best AU Parameters and Data option displays the applicable information:

The **Neighboring AU Data table** displays the following details for each AU with which the unit can communicate:

- **MAC Address**
- **SNR** of the received signal
- **RSSI** of the received signal
- **Mark** - The computed quality mark for the AU.
- **Full** - The association load status of the AU. It is defined as full if the number of SUs associated with the AU has reached the maximum allowed according to the value of the **Maximum Number of Associations** parameter. An AU whose associations load status is full cannot be selected as the Best AU, even if its computed mark is the highest.
- **ESSID** - The ESSID of the AU.

In addition to the neighboring AU data table, the following information is displayed:

- **Best AU Support**
- **Preferred AU MAC Address**
- **Number of Scanning Attempts**
- **Associated AU MAC Address** (the MAC address of the selected AU)

#### 4.2.6.2.7 Scanning Mode (SU only)

The Scanning Mode parameter defines whether the SU will use Passive or Active scanning when searching for an AU.

In passive scanning, the SU “listens” to the wireless medium for approximately two seconds at each frequency, searching for beacons. The disassociation period, which is the time from the moment the link was lost until the SU decides that it should start searching for another AU, is approximately seven seconds.

In some situations when there is a high probability that SUs might need to roam among different AUs, the use of active scanning enables to significantly reduce

the link establishment time. This is achieved by using shorter dwell periods, transmitting a Probe Request at each frequency. This reduces the time spent at each frequency as well as the disassociation period.

When DFS is supported by the Country Code being used by the SU, Scanning Mode is forced to Passive.

The default selection is Passive.

#### 4.2.6.2.8 Power Control Parameters

The Automatic Transmit Power Control (ATPC) algorithm simplifies the installation process and ensures optimal performance while minimizing interference to other units. This is achieved by automatically adjusting the power level transmitted by each SU according to the actual level at which it is received by the AU. To support proper operation of the system with optimal performance and minimum interference between neighboring sectors, the ATPC algorithm should be enabled in all units.

The algorithm is controlled by the AU that calculates for each received frame the average SNR at which it receives transmissions from the specific SU. The average calculation takes into account the previous calculated average, thus reducing the effect of short temporary changes in link conditions. The weight of history (the previous value) in the formula used for calculating the average SNR is determined by a configurable parameter. In addition, the higher the time that has passed since the last calculation, the lower the impact of history on the calculated average. If the average SNR is not in the configured target range, the AU transmits to the SU a power-up or a power-down message. The target is that each SU will be received at an optimal level, or as high (or low) as possible if the optimal range cannot be reached because of specific link conditions.

Each time that the SU tries to associate with the AU (following either a reset or loss of synchronization), it will initiate transmissions using its **Transmit Power** parameters. If after a certain time the SU does not succeed to synchronize with the AU, it will start increasing the transmit power level.

In an AU the maximum supported transmit power is typically used to provide maximum coverage. However, there may be a need to decrease the transmitted power level in order to support relatively small cells and to minimize the interference with the operation of neighboring cells, or for compliance with local regulatory requirements.

In some cases the maximum transmit power of the SU should be limited to ensure compliance with applicable regulations or for other reasons.

Different power levels may be used for different modulation levels by taking into account possible HW limitations or regulatory restrictions.

#### 4.2.6.2.8.1 Transmit Power

The Transmit Power submenu includes the following options:

- Transmit Power
- Show Transmit Power Parameters

##### 4.2.6.2.8.1.1 *Transmit Power*

In the AU, the Transmit Power parameter defines the fixed transmit power level and is not part of the ATPC algorithm.

In the SU, the Transmit Power parameter defines the fixed transmit power level when the ATPC algorithm is disabled. If the ATPC Option is enabled, the value configured for this parameter serves for setting the initial value to be used by the ATPC algorithm after either power up or losing synchronization with the AU.

The minimum value for the Transmit Power Parameter is -10 dBm (the ATPC may reduce the actual transmit power of the SU to lower values). The maximum value of the Transmit Power Parameter depends on several unit properties and parameters:

- The HW revision of the unit
- The Maximum Allowed Tx Power as defined for the applicable Sub-Band.
- The Maximum EIRP as defined for the applicable Sub-Band, together with the value of the Antenna Gain. In certain countries the Maximum EIRP of some equipment types cannot exceed a certain value. In these cases the Transmit Power cannot exceed the value of (Maximum EIRP – Antenna Gain).
- Maximum Tx Power parameter (in SU only)

For information on how to view the Sub-Bands supported by the unit and the supported parameters' values and options, refer to section [4.2.2.4](#).

The unit calculates the maximum allowed Transmit Power according to the unit properties and parameters listed above, and displays the allowed range when a Transmit Power parameter is selected.

For each modulation level, the unit will use as transmit power the minimum between this parameter and the maximum Tx power allowed by the HW and the Country Code for the specific modulation level.

The default Transmit Power is the highest allowed value.

On VL 900 AUs with hardware revision G and VL 900 SUs with hardware revision F, the transmit power cannot vary beyond certain thresholds. For this purpose, the maximum transmission power is limited by the unit's maximum modulation, which sets the minimum transmission power level, according to regulations.

Max. Modulation	TX power per modulation							
	8	7	6	5	4	3	2	1
8	19 dBm	20 dBm	22 dBm	24 dBm	24 dBm	24 dBm	24 dBm	24 dBm
7		20 dBm	22 dBm	24 dBm	26 dBm	26 dBm	26 dBm	26 dBm
6			22 dBm	24 dBm	26 dBm	27 dBm	27 dBm	27 dBm
5				24 dBm	26 dBm	27 dBm	27 dBm	27 dBm
4					26 dBm	27 dBm	27 dBm	27 dBm
3						27 dBm	27 dBm	27 dBm
2							27 dBm	27 dBm
1								27 dBm

#### 4.2.6.2.8.1.2 Show Transmit Power Parameters

This option displays the Transmit Power parameter and the current transmit power for the different modulation levels.

#### 4.2.6.2.8.2 Maximum Transmit Power (SU only)

The Maximum Transmit Power submenu includes the following options:

- Maximum Tx Power
- Show Maximum Tx Power Parameters

##### 4.2.6.2.8.2.1 Maximum Tx Power

The Maximum Tx Power parameter limits the maximum transmit power that can be reached by the ATPC algorithm. It also sets the upper limits for the Transmit Power parameters.

The minimum value for the Maximum Tx Power is -10 dBm. The maximum value depends on several unit properties and parameters:

- The HW revision of the unit
- The Maximum Allowed Tx Power as defined for the applicable Sub-Band.
- The Maximum EIRP as defined for the applicable Sub-Band, together with the value of the Antenna Gain. In certain countries the Maximum EIRP of some equipment types cannot exceed a certain value. In these cases the Transmit Power cannot exceed the value of (Maximum EIRP – Antenna Gain).

For information on how to view the Sub-Bands supported by the unit and the supported parameters' values and options, refer to section [4.2.2.4](#).

The unit calculates the maximum allowed Maximum Tx Power according to the unit properties and parameters listed above, and displays the allowed range when the Maximum Tx Power parameter is selected.

For each modulation level, the unit will use as maximum transmit power the minimum between this parameter and the maximum Tx power allowed by the HW and the Country Code for the specific modulation level.

The default Maximum Tx Power is the highest allowed value.

#### **4.2.6.2.8.2 Show Maximum Tx Power Parameters**

This option displays the Maximum Tx Power parameter and the current maximum Tx power for the different modulation levels.

#### **4.2.6.2.8.3 ATPC Parameters in AU**

##### **4.2.6.2.8.3.1 ATPC Option**

The ATPC Option enables or disables the Automatic Transmit Power Control (ATPC) algorithm.

The default is Enable.

##### **4.2.6.2.8.3.2 ATPC Minimum SNR Level**

The Minimum SNR Level defines the lowest SNR at which you want each SU to be received at the AU (the lower limit of the optimal reception level range).

Available values: 4 to 60 (dB).

Default value: 28 (dB).

##### **4.2.6.2.8.3.3 ATPC Delta from Minimum SNR Level**

The Delta from Minimum SNR Level is used to define the highest SNR at which you want each SU to be received at the AU (the higher limit of the optimal reception level range):

Max. Level=Minimum SNR Level + Delta from Minimum SNR Level.

Available values: 4 to 20 (dB).

Default value: 5 (dB) for units operating in the 0.9, 5.4 and 5.8 GHz bands. 8 (dB) for units operating in the 4.9, 5.2 and 5.3 GHz bands.

#### 4.2.6.2.8.3.4 *Minimum Interval Between ATPC Messages*

The Minimum Interval Between ATPC Messages parameter sets the minimal time between consecutive power-up/power-down messages to a specific SU. Setting a low value for this parameter may lead to higher overhead and to an excessive rate of power level changes at the SUs. High values for this parameter increase the time it will take the SUs to reach optimal transmit power level.

Available values: 1 to 3600 seconds.

Default value: 30 seconds.

#### 4.2.6.2.8.3.5 *ATPC Power Level Step*

The ATPC Power Level Step parameter defines the step size to be used by the SUs for incrementing/decrementing the **Current Transmit Power** after receiving a power-up/power-down message. If the distance between the value of the **Current Transmit Power** and the desired range is smaller than the step size, the power-up/power-down message will include the specific step value required for this condition.

Valid range: 1-20 (dB)

Default value: 5 (dB)

### 4.2.6.2.8.4 *ATPC Parameters in SU*

#### 4.2.6.2.8.4.1 *ATPC Option*

The ATPC Option enables or disables the Automatic Transmit Power Control (ATPC) algorithm. The parameter takes effect immediately. However, when changed from Enable to Disable, the transmit power level will remain at the last Current Transmit Power determined by the ATPC algorithm before it was disabled. It will change to the value configured for the Initial Transmit Power parameter only after the next reset or following loss of synchronization.

The default is Enable.

#### NOTE



The accuracy of the Transmit Power level is typically +/- 1 dB. However, at levels that are 15 dB or more below the maximum supported by the hardware, the accuracy is +/- 3 dB (for information on hardware limitations refer to the Country Codes document). At these levels the use of ATPC may cause significant fluctuations in the power level of the transmitted signal. When operating at such low levels, it is recommended to disable the ATPC Option and to set the Transmit Power parameter to the average Tx Power level before the ATPC was disabled.

#### 4.2.6.2.8.5 Tx Control (AU only)

The Tx Control option enables turning Off/On the AU's transmitter, or having the AU Tx status controlled by the status of the Ethernet port/link.

If the selected option is Ethernet Status Control, then:

- If the Ethernet link is down, the AU transmitter will be switched to Off
- If the Ethernet link is up, the AU transmitter will be switched to On.

This feature can be used during maintenance or testing to avoid transmissions using undesired parameters.

The parameter is available only when managing the unit from its Ethernet port.

The default is On.

#### 4.2.6.2.9 Antenna Gain

The Antenna Gain parameter enables to define the net gain of a detached antenna. The configured gain should take into account the attenuation of the cable connecting the antenna to the unit. The Antenna Gain is important especially in countries where there is a limit on the EIRP allowed for the unit; the maximum allowed value for the Transmit Power parameters cannot exceed the value of (EIRP - Antenna Gain), where the EIRP is defined in the selected Sub-Band.

In certain units with an integral antenna the Antenna Gain is not available as a configurable parameter. However, it is available as a read-only parameter in the applicable "Show" menus.

The lower limit for the Antenna Gain parameter is 0 (dBi). The upper limit for the Antenna Gain is Regulation Max EIRP + 10 in dBi (since the minimum Tx Power is -10dBm), up to a maximum of 50 (dBi). If Regulation Max EIRP is No Limit, the upper limit is 50 (dBi). A value of "Don't Care" means that the actual value is not important. A value of "Not Set Yet" means that the unit will not transmit until the actual value (in the range 0 to 50) is configured. The unit can be configured to "Don't Care" or "Not Set Yet" only in factory (when upgraded to SW version 2.0 from a lower version it will be set automatically to one of these options). Once a value is configured, it is not possible to reconfigure the unit to either "Don't Care" or "Not Set Yet".

The default value depends on unit type. In SUs with integral antenna it is set to 21 (read only). The default value for AUs that are supplied with a detached antenna is in accordance with the antenna's gain. In units supplied without an antenna the default is typically "Not Set Yet".

#### 4.2.6.2.10 Cell Distance Parameters (AU only)

The higher the distance of an SU from the AU that is serving it, the higher the time it takes for messages sent by one of them to reach the other. To ensure appropriate services to all SUs regardless of their distance from the AU while maintaining a high overall performance level, two parameters should be adapted to the distances of SUs from the serving AU:

- The time that a unit waits for a response message before retransmission (ACK timeout) should take into account the round trip propagation delay between the AU and the SU (The one-way propagation delay at 5 GHz is 3.3 microseconds per km/5 microseconds per mile.). The higher the distance from the AU of the SU served by it, the higher the ACK timeout should be. The ACK timeout in microseconds is:  $20 + \text{Distance (km)} * 2 * 3.3$  or  $20 + \text{Distance (miles)} * 2 * 5$ .
- To ensure fairness in the contention back-off algorithm between SUs located at different distances from the AU, the size of the time slot should also take into account the one-way propagation delay. The size of the time slot of all units in the cell should be proportional to the distance from the AU of the farthest SU served by it.

The Cell Distance Mode parameter in the AU defines the method of computing distances. When set to Manual, the Maximum Cell Distance parameter should be configured with the estimated distance of the farthest SU served by the AU. When set to Automatic, the AU uses a special algorithm to estimate its distance from each of the SUs it serves, determine which SU is located the farthest and use the estimated distance of the farthest SU as the maximum cell distance. The value of the maximum cell distance parameter (either computed or configured manually) is transmitted in the beacon messages to all SUs served by the AU, and is used by all units to calculate the size of the time slot, that must be the same for all units in the same sector. When the Per SU Distance Learning option is enabled, the AU uses the re-association message to send to each SU its estimated distance from the AU. The per-SU distance is used to calculate the ACK timeout to be used by the SU. When the Per SU Distance Learning option is disabled (or if it cannot be used because the SU uses a previous SW version that does not support this feature), the SU will use the maximum cell distance to calculate the ACK timeout. The AU always uses the maximum cell distance to calculate the ACK timeout.

It should be noted that if the size of the time slot used by all units is adapted to the distance of the farthest unit, then no unit will have an advantage when competing for services. However, this reduces the overall achievable throughput of the cell. In certain situations, the operator may decide to improve the overall throughput by reducing the slot size below the value required for full fairness (using the Fairness Factor parameter). This means that when there is competition

for bandwidth, the back-off algorithm will give an advantage to SUs that are located closer to the AU.

The Cell Distance Parameters menu includes the following parameters:

#### 4.2.6.2.10.1 Cell Distance Mode

The Cell Distance Mode option defines whether the maximum distance of the AU from any of the SUs it serves will be determined manually (using the Maximum Cell Distance parameter) or automatically. In addition, the Per SU Distance Learning feature is supported only when the Cell Distance Mode is set to Automatic.

The Options are Automatic or Manual.

The default is Automatic.

#### 4.2.6.2.10.2 Maximum Cell Distance

The Maximum Cell Distance parameter allows configuring the maximum distance when the Cell Distance Mode option is Manual.

The range is 0 to 54 (Km). The value of 0 has a special meaning for No Compensation: Acknowledge Time Out is set to a value representing the maximum distance of 54 km. The time slot size is set to its minimal value of 9 microseconds.

The default is 0 (No Compensation).

#### 4.2.6.2.10.3 Fairness Factor

The Fairness Factor enables to define the level of fairness in providing services to different SUs. When set to 100%, all SUs have the same probability of getting services when competing for bandwidth. If set to X%, then SUs located up to X% of the maximum distance from the AU will have an advantage in getting services over SUs located farther than this distance.

The range is 0 to 100 (%)

The default is 100 (%).

#### 4.2.6.2.10.4 Per SU Distance Learning

The Per SU Distance Learning option defines the mode in which SUs calculate the ACK timeout: based on the maximum cell distance or on the actual distance from the AU.

When this feature is disabled, all SUs in the cell use for the calculation of the ACK timeout the maximum cell distance; when enabled, each SU uses instead its actual distance from the AU.

The options are Disable or Enable.

The default is Disable.

#### 4.2.6.2.10.5 Show Cell Distance Parameters

Select Show Cell Distance Parameters to view the Cell Distance parameters. In addition, the Measured Maximum Cell Distance and the MAC address of the unit that the mechanism found to be the farthest from the AU are displayed.

#### 4.2.6.2.11 Arbitration Inter-Frame Spacing (AIFS)

The time interval between two consecutive transmissions of frames is called Inter-Frame Spacing (IFS). This is the time during which the unit determines whether the medium is idle using the carrier sense mechanism. The IFS depends on the type of the next frame to be transmitted, as follows:

- SIFS (Short Inter-Frame Spacing) is used for certain frames that should be transmitted immediately, such as ACK and CTS frames. The value of SIFS is 16 microseconds.
- DIFS (Distributed coordination function Inter-Frame Spacing) is typically used for other frame types when the medium is free. If the unit decides that the medium is not free, it will defer transmission by DIFS plus a number of time slots as determined by the Contention Window back-off algorithm (see section [Q](#)) after reaching a decision that the medium has become free.

DIFS equal SIFS plus AIFS, where AIFS can be configured to a value from 1 to 50 time slots. A unit with a lower AIFS has an advantage over units with a higher AIFS, since it has a better chance to gain access to limited wireless link resources. Typically, AIFS should be configured to two time slots. A value of 1 should only be used in one of the two units in a point-to-point link, where in the other unit the AIFS remains configured to two time slots. This ensures that the unit with AIFS configured to one has an advantage over the other unit, provided that the [Minimum Contention Window](#) (section [Q](#)) parameter in both units is configured to 0 to disable the contention window back-off algorithm.

#### NOTE



The AIFS parameter is not applicable when the Wireless Link Prioritization Option is enabled.

The available range is from 1 to 50 (time slots).

The default is 2 time slots.

#### CAUTION



An AIFS value of 1 should only be used in point-to-point applications (when the Wireless Link Prioritization Option is enabled). Otherwise the default value of 2 must always be used. In a point-to-point link, only one unit should be configured to an AIFS value of 1. When both units need to transmit, the unit with an AIFS value of 1 will have an advantage over the unit with AIFS of 2. In this case, the Minimum Contention Window parameter in both units must be configured to 0 to disable the contention window back-off algorithm.

#### 4.2.6.2.12 Maximum Number of Associations (AU only)

The Maximum Number of Associations parameter defines the maximum number of Subscriber Units that can be associated with the selected AU, while still guaranteeing the required quality of service to customers.

Available values for AU-BS and AU-SA range from 0 to 512. For AUS-BS and AUS-SA the range is from 0 to 8.

Default value for AU-BS and AU-SA is 512. For AUS-BS and AUS-SA the default is 8.

##### NOTE



The Maximum Number of Associations must be set to a value of 124 or lower to enable Data Encryption. As long as Data Encryption is enabled, the Maximum Number of Associations cannot be set to a value higher than 124.

The Maximum Number of Associations Limit (512 when Data Encryption is disabled, 124 when Data Encryption is enabled) is indicated in the Show Air Interface Parameters display.

##### NOTE



There is no aging time for SUs. An SU is only removed from the list of associated SUs under the following conditions:

- The SU failed to respond to 100 consecutive data frames transmitted by the AU and is considered to have "aged out".
- During the last 6 minutes (or more) the SU did not transmit any data frame, and failed to respond to certain frames that typically are transmitted by the AU every 10 seconds. Since the sampling interval for this state is about 10 minutes, it means that the decision to remove the SU from the Associations Database will take place between 6 to 16 minutes from the time the SU ceased sending data or responding to these "keep-alive" frames (for AUS the sampling interval is 1 minute, meaning decision time of 6 to 7 minutes).

Therefore, the database of associated SUs may include units no longer associated with the AU. If the number of associated SUs has reached the value of the Maximum Number of Associations parameter, the selected AU cannot serve additional SUs. To view the current number of associated SUs, use the Display Association Info option in the MAC Address Database menu. To delete inactive SUs from the database you must either disassociate them (see 4.2.6.2.16) or reset the AU.

#### 4.2.6.2.13 Wireless Link Trap Threshold (AU only)

The Wireless Link Trap Threshold parameter defines the threshold for the wireless quality trap, indicating that the quality of the wireless link has dropped below (on trap) or has increased above (off trap) the specified threshold.

The Wireless Link Trap Threshold is in percentage of retransmissions, and the allowed range is from 1 to 100 (%).

The default is 30 (%).

#### 4.2.6.2.14 Spectrum Analysis

Gaining knowledge of the noise characteristics per channel enables construction of a relatively noise free working environment. In order to gain information regarding noise characteristics in the location of the unit, the unit will enter

passive scanning mode for a definite period, during which information will be gathered. The scanned channels will be all the frequencies included in the selected sub-band.

Upon activating the spectrum analysis the unit will automatically reset. During the information-gathering period the unit will not receive nor transmit data. It also will not be able to synchronize/associate, meaning that it cannot be managed via the wireless link. During the spectrum analysis period the unit security mode is changed to promiscuous to enable gathering information regarding all legal frames received by the unit. At the end of the period the unit will reset automatically regaining normal operability upon start up.

The Spectrum Analysis submenu includes the following options:

#### 4.2.6.2.14.1 Spectrum Analysis Channel Scan Period

The Spectrum Analysis Channel Scan Period is the period of staying on each channel during each cycle for information gathering when performing spectrum analysis.

Range: 2-30 seconds.

Default value: 5 seconds.

#### 4.2.6.2.14.2 Spectrum Analysis Scan Cycles

The Spectrum Analysis Scan Cycle is the number of scanning cycles when performing Spectrum Analysis.

Range: 1-100 cycles.

Default value: 2 cycles.

#### 4.2.6.2.14.3 Automatic Channel Selection (AU only)

The Automatic Channel selection option defines weather the AU will choose the best noise free channel upon startup after completion of the spectrum analysis process. The selection is per analysis: when the analysis is completed it will be disabled automatically.

The default is Disable.

#### 4.2.6.2.14.4 Spectrum Analysis Activation

The Spectrum analysis Activation option enables activation of the spectrum analysis process. Upon activation, the unit will reset automatically and start-up in spectrum analysis mode.

#### 4.2.6.2.14.5 Reset Spectrum Analysis Information

The Reset Spectrum Analysis Information option enables resetting the spectrum analysis counters.

#### 4.2.6.2.14.6 Spectrum Analysis Information Display

The Spectrum Analysis Information Display option enables viewing the results of the last analysis process. The displayed information includes the following details for each channel:

- **Frequency in MHz**
- **Signal Count:** The number of signals (excluding OFDM frames with the correct bandwidth) in the channel.
- **Signal SNR:** The average SNR of signals (excluding OFDM frames with the correct bandwidth) in the channel.
- **Signal Max SNR:** The maximum SNR of signals (excluding OFDM frames with the correct bandwidth) in the channel.
- **Signal Width:** The average width in microseconds of signals (excluding OFDM frames with the correct bandwidth) in the channel.
- **OFDM Frames:** The number of OFDM frames with the correct bandwidth detected in the channel.
- **OFDM SNR:** The average SNR (in dB) of OFDM frames received in the channel.
- **OFDM Max SNR:** The maximum SNR (in dB) of OFDM frames received in the channel.
- **Noise Floor Avg:** The average Noise Floor (in dBm) calculated for the channel.
- **Noise Floor Max:** The maximum Noise Floor (in dBm) calculated for the channel.

#### 4.2.6.2.14.7 Spectrum Analysis Information Display - Continuous

The Spectrum Analysis Information Display - Continuous option is available only when the analysis process is active. It enables viewing the continuously updated results of the current analysis process. The displayed information includes the same details available for a regular Spectrum Analysis Information Display option.

#### 4.2.6.2.14.8 Show Spectrum analysis Parameters & Data

The Show Spectrum analysis Parameters & Data option enables viewing the Spectrum analysis test parameters and the last test results.

#### 4.2.6.2.15 Lost Beacons Transmission Watchdog Threshold (AU only)

When it is unable to send beacon frames for a predetermined period of time, such as in the case of interferences, the AU resets itself. The Lost Beacons Transmission Threshold parameter represents the number of consecutive lost beacons after which the unit will reset itself.

The range for this parameter is 100 – 1000 or 0. When the parameter is set to 0, this feature is disabled, i.e. internal refresh will never be performed.

The default value is 218.

#### 4.2.6.2.16 Disassociate (AU only)

The Disassociate feature enables disassociating all SUs associated with the AU or a selected SU. This feature is useful during configuration changes, enabling to force the SU(s) to re-initiate the association process, including the search for the best AU (or a preferred AU) using the Best AU process, without performing a full reset.

The Disassociate submenu includes two options:

- **Disassociate All SUs**
- **Disassociate SU By MAC Address:** to disassociate a selected SU

#### 4.2.6.2.17 Noise Immunity Control

Noise Immunity Control parameters are available only in units with HW Revision C and higher, except to the Pulse Detection Sensitivity parameter that is available also in units with HW Revision B.

The Adaptive Noise Immunity (ANI) mechanism is designed to reduce the wireless physical layer errors and by that enhance the processing power of the unit, delivering higher packet processing efficiency.

This ANI mechanism is triggered by the rate of detected Physical Errors and it is modifying different thresholds affecting the immunity to specific interference types.

This feature, active by default, exists in all units with HW revision C and higher running SW version 3.0 and higher. Starting in SW version 4.0, the processing power of the system has been increased dramatically. When using version 4.0 the units are capable to process more packets per seconds, including physical error packets. As a result, the ANI mechanism (triggered by the number of received error packets) may not function properly in certain scenarios, resulting in link performances that are far below the expectations. The option of manually controlling the various parameters used by the ANI mechanism enables to

achieve optimal performance in certain deployments where the automatic ANI mechanism may not function properly.

It is strongly recommended to consult with Alvarion experts before switching to manual mode and modifying any of the parameters.

The general rules for using the Noise Immunity Control parameters are:

In the SU, if performance (Modulation Level) is lower than expected based on the SNR, try switching to Manual mode without changing any of the parameters.



#### CAUTION

Do not change any of the SU's Noise Immunity Control parameters (except the Noise Immunity State Control) from remote, as it may result in loss of connectivity to the unit.

In the AU, try switching to Manual mode if overall throughput is too low or if SUs are lost although communication conditions are sufficient for good connectivity.

In many deployments the transition to Manual mode is sufficient. If not, you may try changing the Noise Immunity Level and/or Spur Immunity Level parameters. The target is to reduce the amount of Phy Error rate reported by the unit (see **Total Rx events** on page 117). To ensure that sensitivity is not reduced too much and SUs are not lost, verify that the Age (see **Display Association Info** on page 121) of all SUs is below 20 seconds.

Do not activate the OFDM Weak Signal parameter if the SNR is below 36 dB. Under normal conditions, the OFDM Weak Signal should never be activated in the AU, since the SNR of all SUs will be below 36 dB when ATPC is enabled.

The Noise Immunity Control submenu includes the following options:

#### 4.2.6.2.17.1 Noise Immunity State Control

The Noise Immunity State Control defines the activation mode of the Adaptive Noise Immunity mechanism: Automatic or Manual. The following parameters of the Noise Immunity Control mechanism are applicable only for Manual mode.

The default is Automatic.

#### 4.2.6.2.17.2 Noise Immunity Level

The Noise Immunity Level parameter sets the threshold for immunity against broadband interfering signals. A higher value may reduce the number of errors at the expense of reduced sensitivity.

The range is from 0 to 4. In the current version only 0 and 4 should be used.

The default is 0.

#### 4.2.6.2.17.3 Spur Immunity Level

The Spur Immunity Level parameter sets the threshold for immunity against narrow band interfering signals such as spurious from signals at other

frequencies. A higher value may reduce the number of errors at the expense of reduced sensitivity.

The range is from 0 to 7.

The default is 0.

#### 4.2.6.2.17.4 OFDM Weak Signal

The OFDM Weak Signal parameter sets the threshold for immunity against interfering OFDM signals.

The available options are 0 or 1. A value of 1 means that the unit will immediately reject OFDM packets with a relatively low SNR.

The default is 0.

#### 4.2.6.2.17.5 Pulse Detection Sensitivity

The Pulse Detection Sensitivity parameter affects the Phy error count: If it is set to Low, than all Phy errors will be reported as regular Phy errors, regardless of the signal level. If it is set to High, all Phy errors with levels bellow a certain threshold (not accessible to the user) will be reported as regular Phy errors, while those with levels higher than the threshold will be reported as detected radar pulses.

When DFS (radar detection) is used or during a Spectrum Analysis test, the Pulse Detection Sensitivity is set internally to High (regardless of the configured value).

The default is Low.

#### 4.2.6.2.17.6 Show Noise Immunity

Select this option to view the current values of the Noise Immunity Control parameters, and some additional parameters of the ANI mechanism.

#### 4.2.6.2.18 Noise Floor Calculation Parameters

The Noise Floor calculation mechanism incorporated in the units is used for estimating the level of the noise floor. This value is used for estimating SNR values and for decisions on existence of signals in the channel. In some cases, especially when a very strong signal exists in neighboring channels, the noise floor calculated by the built-in mechanism may be significantly below the actual noise floor level.

Typically, the expected noise floor level is:

- 5 MHz bandwidth: -102 (dBm)
- 10 MHz bandwidth: -99 (dBm)
- 20 MHz bandwidth: -96 (dBm)

The default calculation mode is Fully Automatic, using only the built-in mechanism. If you experience problems in the wireless link such as excessively long association process or very low throughput, it may be caused by errors in noise floor calculation. In this case, it is recommended to perform a Spectrum Analysis (see section 4.2.6.2.14 on page 150) and view the Average Noise Floor values. If the calculated Noise Floor is lower by more than 5 dB from the expected value, it is recommended to change the calculation mode to Automatic with Minimum Value, using the expected value as the minimum (Forced Value).

Note that if the SNR of received signals is very low (typically below 10 dB), it is recommended to maintain the default calculation mode (Fully Automatic). Changing the calculation mode to Automatic with Minimum Value may result in loss of connectivity with units for which the calculated SNR before the change was relatively low.

The Noise Floor Calculation Parameters submenu includes the following options:

#### 4.2.6.2.18.1 Calculation Mode

The Calculation Mode defines the method used for calculation the Noise Floor value to be used by the device for estimating the quality of received signals. The available options are:

- **Fully Automatic:** According to the built-in noise floor calculation mechanism.
- **Forced:** The Noise Floor value is set manually to the value configured for the Forced Value parameter (see below). Typically this mode should be used only for special testing purposes.
- **Automatic with Minimum Value:** If the calculated Noise Floor using the built-in mechanism is higher than the value configured for the Forced Value parameter, the calculated value will be used. Otherwise, the Forced Value will be used.

The default option is Fully Automatic.

#### 4.2.6.2.18.2 Forced Value

The Forced Value parameter enables configuring the Noise Floor to be used if the selected Calculation Mode is Forced. This is also the minimum value to be used if the selected Calculation Mode is Automatic with Minimum Value.

If you decided to change the calculation mode to Automatic with Minimum Value and you still experience problems in the link (long association time, exceptionally low throughput), try to improve it by increasing the configured Forced Value.

The available range is from -107 to -55 (dBm)

The default value is:

- 5 MHz bandwidth: -102 (dBm)
- 10 MHz bandwidth: -99 (dBm)
- 20 MHz bandwidth: -96 (dBm)

#### 4.2.6.2.18.3 Show Noise Floor Calculation

Select this option to view the current values of the Noise Floor Calculation parameters and the Noise Floor Current Value (the actual current value used by the device).

#### 4.2.6.2.19 Interference Mitigation (VL 900 only)

The Interference Mitigation functionality allows users to configure the unit's operating channel and noise floor level in order to meet particular requirements regarding throughput and distance. The unit will scan and analyse the 900 MHz spectrum, and, depending on the detected noise levels, it will choose an optimal operating channel and noise floor level.

There are two types of optimization mechanisms available. The unit can either find settings that will ensure the best range for a given throughput or settings that will ensure the best throughput for a given range. Based on the sector's topography, the unit estimates a theoretical link budget, and matches it against the noise levels detected during the scan to identify the settings that best meet the user's requirements.

The Interference Mitigation offers a quick and efficient mechanism for setting up access units in the noisy environment of the 900 MHz band, when the operator doesn't have the time or the expertise required for a full spectrum analysis and channel optimization. For optimal results however, a thorough radio planning performed by a radio specialist is always recommended.

#### CAUTION



Upon activating the Interference Mitigation, the unit will automatically reset. The unit will enter passive scanning mode for a definite period of time, during which information will be gathered. During the information-gathering period, the unit will not receive nor transmit data. Also, it will not be able to synchronize/associate, meaning that it cannot be managed via the wireless link. At the end of the period, the unit will reset automatically regaining normal operability upon start up.

#### 4.2.6.2.19.1 Basic Settings

The Basic Settings menu is used for collecting the primary input required for the analysis process.

##### 4.2.6.2.19.1.1 *Installation Model*

This setting defines the sector's topography

- 0 – LOS: Units have clear line of sight between them
- 1 – Near LOS: Units have minor obstacles in their path, which are easily avoidable through multipath
- 2 – Non LOS: Units are obstructed and the signal must travel through longer paths or less permissive media

#### 4.2.6.2.19.1.2 *Minimum Desired Performance*

This setting defines the minimum throughput that must be ensured when optimizing the achievable distance. Not applicable when the Optimize Performance for Minimum Desired Distance optimization criterion is used.

The available range is from 500 to 6000 (kbps).

The default is 3000 (kbps).

#### 4.2.6.2.19.1.3 *Minimum Desired Distance*

This setting defines the minimum achievable distance that must be reached when optimizing the throughput. Not applicable when the Optimize Distance for Minimum Desired Performance optimization criterion is used.

The available range is from 500 to 54000 (meters).

The default is 3000 (meters).

#### 4.2.6.2.19.1.4 *Channel Selection Optimization Criteria*

This setting allows you to select the optimization mechanism that will be employed:

- 0 – Optimize Performance for Minimum Desired Distance: Ensures the best throughput while preserving the Minimum Desired Distance
- 1 – Optimize Distance for Minimum Desired Performance: Ensures the best achievable distance while preserving the Minimum Desired Performance

#### 4.2.6.2.19.1.5 *Scanning Type*

This setting defines the output of the analysis process performed by the Interference Mitigation mechanism:

- 0 – Clear Channel Selection + Automatic Noise Floor Selection: For optimizing both the operating channel and noise floor level (AU only)

- 1 – Automatic Noise Floor Selection: For optimizing only the noise floor level
- 2 – Clear Channel Selection: For optimizing only the operating channel (AU only)
- 3 – Statistics Only: For performing only a spectrum analysis, without modifying the operating channel or noise floor level

#### 4.2.6.2.19.2 Advanced Settings

Use this menu to provide additional parameters that will refine the analysis performed by the Interference Mitigation mechanism. You can ignore these parameters, leaving their default settings in place. However, filling in as many of them as possible, will optimize the process, providing better results.

##### 4.2.6.2.19.2.1 *AU Height*

Indicates the height (in meters) of the AU antenna. It is useful for calculating the distance.

The available range is from 15 to 200 (meters).

The default is 30 (meters).

##### 4.2.6.2.19.2.2 *AU/SU Antenna Gain*

- SU Antenna Gain: The antenna gain (in dBi) for a typical SU (AU only).

The available range is from 9 to 20 (dBi).

The default is 17 (dBi).

- AU Antenna Gain: The antenna gain (in dBi) for the AU (SU only).

The available range is from 9 to 20 (dBi).

The default is 12 (dBi).

##### 4.2.6.2.19.2.3 *AU/SU Maximum Modulation*

- SU Maximum Modulation: The maximum modulation of the SUs in the link.

The available range is from 1 to 8.

The default is 5.

- AU Maximum Modulation: The maximum modulation of the AU in the link.

The available range is from 1 to 8.

The default is 8.

#### 4.2.6.2.19.2.4 *KeepLink (AU only)*

Activates or deactivates the KeepLink feature:

- 0 – Disable KeepLink
- 1 – Enable KeepLink

The default is 1 (Enabled).

#### 4.2.6.2.19.2.5 *Channel Scan Period*

The period of time, in seconds, the unit will stay on each channel to gather information. The unit may stop recording prematurely if a 100 000 events limit is reached.

The available range is from 2 to 30 minutes.

The default is 5 minutes.

#### 4.2.6.2.19.2.6 *Automatic Scan Period*

The period of time, in minutes, after which the unit will rerun the Interference Mitigation channel scan. Setting this value to 0 will disable periodicity, allowing only one-time manually triggered Interference Mitigation scans.

The available range is 0 (disabled) or 10 - 10080 (minutes)

Default value is 0 (disabled).

#### 4.2.6.2.19.2.7 *Frequency Subset (AU only)*

This setting allows you to select the channels that will be scanned during the Interference Mitigation process. All the defined frequencies and their indexes will be displayed. Frequencies are indexed with consecutive numbers starting from 1. Enter the desired channels' corresponding indexes separated by commas (for example: 1, 4, 5, 6, 14, 18, 19) or enter A to select all defined frequencies.

#### 4.2.6.2.19.3 *Activation*

Starts the Interference Mitigation process. Keep in mind that during the scan, the AU will lose connectivity to the associated SUs. A final validation is required prior to the scan:

- 0 – Cancel Operation
- 1 – Activate Interference Mitigation (Causes Automatic Reset)

After reset, the Interference Mitigation statistics file will be updated, and depending on the Scanning Type you defined, the unit may be configured to a new operating channel and/or noise floor.

#### 4.2.6.2.19.4 Delete Statistics File

Deletes the Interference Mitigation statistics file created during the previous scan. A final validation is required prior to deletion:

- 0 – Cancel Operation
- 1 – Delete File

#### 4.2.6.2.19.5 Show Interference Mitigation Parameters & Data

This feature displays a review of the Interference Mitigation settings and the statistics generated during the latest scan (if the statistics file was not deleted in the meanwhile). These statistics include for each defined channel the following parameters:

- Frequency
- Noise Floor
- Achievable Distance
- Maximum Throughput

### 4.2.6.3 Network Management Parameters

The Network Management Parameters menu enables protecting the Unit from unauthorized access by defining a set of discrete IP addresses as well as IP address ranges from which the unit can be managed using protocols such as Telnet, FTP, TFTP, SNMP, DHCP and ICMP. This excludes management messages generated in the unit, such as Traps or Ping Test frames, which are not filtered. The direction from which management access is permitted can also be configured, which means that management access may be permitted from the wireless medium only, from the wired Ethernet only, or from both.

The Network Management Menu also enables managing transmission of traps, including definition of up to 10 traps destination IP addresses and the associated community strings. In addition, the menu enables specifying the IP address of a connected AP client device to facilitate remote management of a BreezeACCESS WI<sup>2</sup> system.

The Network Management Parameters menu includes the following options:

- Access to Network Management
- Network Management Filtering
- Set Network Management IP address
- Delete a Network Management IP Address
- Delete All Network Management IP Addresses
- Set/Change Network Management IP Address Ranges
- SNMP Traps (AU only)
- Wi2 IP Address (SU only)

#### 4.2.6.3.1 Access to Network Management

The Access to Network Management option defines the port through which the unit can be managed. The following options are available:

- From Wireless Link Only
- From Ethernet Only
- From Both Ethernet and Wireless Link

The default selection is From Both Ethernet and Wireless Link.

**CAUTION**

Be careful not to block your access to the unit. For example, if you manage an SU via the wireless link, setting the Access to Network Management parameter to From Ethernet Only completely blocks your management access to the unit. In this case, a technician may be required to change the settings at the user's site.

#### 4.2.6.3.2 Network Management Filtering

The Network Management Filtering option enables or disables the IP address based management filtering. If management filtering is enabled, the unit can only be managed by stations with IP addresses matching one of the entries in either the Network Management IP Addresses list or in the Network Management IP Address Ranges list, described below, and that are connected to the unit via the defined port(s). The following options are available:

- **Disable:** No IP address based filtering is configured.
- **Activate IP Filter on Ethernet Port:** Applicable only if the Access to Network Management parameter is configured to either From Ethernet Only or From Both Ethernet and Wireless Link. The unit can be managed from the Ethernet port only by stations with IP addresses matching one of the entries in the Set Network Management IP Addresses parameter. If the Access to Network Management parameter is configured to From Both Ethernet and Wireless Link then no IP address based filtering is configured for the wireless port.
- **Activate IP Filter on Wireless Link Port:** Applicable only if the Access to Network Management parameter is configured to either From Wireless Link Only or From Both Ethernet and Wireless Link. The unit can be managed from the wireless port only by stations with IP addresses matching one of the entries in the Set Network Management IP Addresses parameter. If the Access to Network Management parameter is configured to From Both Ethernet and Wireless Link then no IP address based filtering is configured for the Ethernet port.
- **Activate IP filter on Both Ethernet and Wireless Link Ports:** Applicable to all options of the Access to Network Management parameter. The unit can be managed from the port(s) defined by the Access to Network Management parameter only by stations with IP addresses matching one of the entries in the Set Network Management IP Addresses parameter.

The default selection is Disable.

#### 4.2.6.3.3 Set Network Management IP Address

The Set Network Management IP Address option enables defining up to 10 IP addresses of devices that can manage the unit if the Network Management Filtering option is enabled.

The default Network Management IP Address is 0.0.0.0 (all 10 addresses).

#### 4.2.6.3.4 Delete a Network Management IP Address

The Delete Network Management IP Address option enables deleting IP address entries from the Network Management IP Addresses list.

#### 4.2.6.3.5 Delete All Network Management IP Addresses

The Delete All Network Management IP Addresses option enables deleting all entries from the Network Management IP Addresses list.

#### 4.2.6.3.6 Set/Change Network Management IP Address Ranges

The Set/Change Network Management IP address Ranges menu enables defining, updating or deleting IP address ranges from which the unit can be managed if the Network Management Filtering option is enabled. This is in addition to the previous options in the Network Management menu that enable defining, updating and deleting discrete IP addresses.

The menu includes the following options:

##### 4.2.6.3.6.1 Set/Change Network Management IP Address Ranges

The Set/Change Network Management IP Address Ranges option enables defining/updating up to 10 IP address ranges from which the unit can be managed if the Network Management Filtering option is enabled.

The default Network Management IP Address Range is 0.0.0.0 TO 0.0.0.0 (all 10 ranges).

A range can be defined using a string that includes either a start and end address, in the format “<start address> to <end address>” (example: 192.168.1.1 to 192.168.1.255), or a base address and a mask, in the format “<base address> mask <mask>” (example: 192.168.1.1 mask 255.255.255.0).

##### 4.2.6.3.6.2 Delete Network Management IP Address Range

The Delete Network Management IP Address Range option enables deleting IP address range entries from the Network Management IP Address Ranges list.

##### 4.2.6.3.6.3 Delete All Network Management IP Address Ranges

The Delete All Network Management IP Address Ranges option enables deleting all entries from the Network Management IP Address Ranges list.

#### 4.2.6.3.7 SNMP Traps (AU Only)

The SNMP submenu enables or disables the transmission of SNMP Traps. If this option is enabled, up to 10 IP addresses of stations to which SNMP traps are sent can be defined.

Starting on SW Version 5.0, traps are generated and sent only by the AU: relevant events in an SU are reported by the SU to the serving AU that generates the applicable trap on behalf of the SU.

For more details on the system traps see the relevant Traps document.

##### 4.2.6.3.7.1 Send SNMP Traps

The Send SNMP Traps option enables or disables the sending of SNMP traps.

The default selection is Disable.

##### 4.2.6.3.7.2 SNMP Traps Destination IP Addresses

The SNMP Traps Destination IP Addresses submenu enables defining up to 10 IP addresses of devices to which the SNMP Traps are to be sent.

The default of all 10 SNMP Traps IP destinations is 0.0.0.0.

##### 4.2.6.3.7.3 SNMP Traps Community

The SNMP Traps Community option enables defining the Community name for each IP address to which SNMP Trap messages are to be sent.

Valid strings: Up to 8 ASCII characters.

The default for all 10 addresses is “public”, which is the default Read community.

##### 4.2.6.3.7.4 Delete One Trap Address

The Delete One Trap Address option enables deleting Trap address entries from the SNMP Traps Addresses list.

##### 4.2.6.3.7.5 Delete All Trap Addresses

The Delete All Trap Addresses option enables deleting all entries from the SNMP Traps Addresses list.

#### 4.2.6.3.8 Wi2 IP Address (SU Only)

The BreezeACCESS WI<sup>2</sup> system comprises a self-contained combination of an advanced WiFi Access Point and a BreezeACCESS SU-ODU that provides backhaul connectivity. The Wi2 IP Address parameter enables the installer to configure in the SU the IP address of the WiFi AP connected to it, providing availability of the IP address information for remote management of the AP.

The default Wi2 IP Address is 0.0.0.0 (meaning none).

## 4.2.6.4 Bridge Parameters

The Bridge Parameters menu provides a series of parameter sets that enables configuring parameters such as control and filtering options for broadcast transmissions, VLAN support, and Type of Service prioritization.

The Bridge Parameters menu includes the following options:

- VLAN Support
- Ethernet Broadcast Filtering (SU only)
- Ethernet Broadcast/Multicast Limiter
- Bridge Aging Time
- Roaming Option (SU only)
- Broadcast/Multicast Relaying (AU only)
- Unicast Relaying (AU only)
- MAC Address List (AU only)

### 4.2.6.4.1 VLAN Support

The VLAN Support menu enables defining the parameters related to the IEEE 802.1Q compliant VLAN aware (Virtual LAN aware) feature of the units. Each VLAN includes stations that can communicate with each other, but cannot communicate with stations belonging to different VLANs. The VLAN feature also provides the ability to set traffic priorities for transmission of certain frames. The information related to the VLAN is included in the VLAN Tag Header, which is inserted in each frame between the MAC header and the data. VLAN implementation in BreezeACCESS VL units supports frame routing by port information, whereby each port is connected to only one VLAN.

The system also supports the 802.1 QinQ standard, which defines the way to have 2 VLAN tags (double-tagged frames). This procedure allows an additional VLAN tag, called Service Provider VLAN tag, to be inserted into an existing IEEE 802.1Q tagged Ethernet frame. This is a solution to transport multiple customers' VLANs across the service provider's network without interfering with each other.

The VLAN Support menu includes the following parameters:

- VLAN Link Type

- VLAN ID – Data (SU only)
- VLAN ID – Management
- Service Provider VLAN ID (SU only)
- VLAN Forwarding
- VLAN Relaying (AU only)
- VLAN Traffic Priority
- VLAN QinQ Protocol Ethertype

#### 4.2.6.4.1.1 VLAN ID-Data (SU only)

The VLAN ID-Data is applicable only when the VLAN Link Type parameter is set to Access Link. It enables defining the VLAN ID for data frames, which identifies the VLAN to which the unit belongs.

Valid values range from 1 to 4094.

Default value: 1.

The VLAN ID-Data affects frames received from the wireless link port, as follows:

- Only tagged frames with a VLAN ID (VID) equal to the **VLAN ID-Data** defined in the unit are forwarded to the Ethernet port.
- The tag headers are removed from the data frames received from the wireless link before they are transmitted on the Ethernet port.

The VLAN ID-Data affects frames received from the Ethernet port, as follows:

- A VLAN Data Tag is inserted in all untagged frames received from the Ethernet port before transmission on the wireless link. The tag includes the values of the **VLAN ID-Data** and the **VLAN Priority-Data** parameters.
- Tagged frames received on Ethernet port, which are meant to be forwarded to the wireless link port, are discarded. This includes frames with tagging for prioritization purposes only.

#### 4.2.6.4.1.2 VLAN ID-Management

The VLAN ID-Management is applicable for all link types. It enables defining the VLAN ID for management frames, which identifies remote stations for management purposes. This applies to all management applications using

protocols such as SNMP, TFTP, ICMP (ping), DHCP and Telnet. All servers/stations using these protocols must tag the management frames sent to the unit with the value of the VLAN ID-Management parameter.

Valid values: 1 to 4094 or 65535 (No VLAN).

The default value is 65535.

If the VLAN ID-Management is other than 65535:

- Only single-tagged management frames with a matching VLAN ID, or double-tagged management frames with a matching Service Provider VLAN ID received on either the Ethernet or wireless link ports are forwarded to the unit.
- A VLAN Management Tag is inserted in all management frames generated by the unit before transmission on either the Ethernet or wireless link port. The tag includes the values of the **VLAN ID-Management** and the **VLAN Priority-Management** parameters.

If the VLAN ID-Management is 65535 (No VLAN):

- For Access, Trunk and Hybrid links: Only untagged management frames received on either the Ethernet or wireless link ports are forwarded to the unit.
- An AU operating in Service Provider link mode with VLAN ID – Management = 65535 cannot be managed from either the Ethernet or wireless ports.
- An SU operating in Service Provider link mode with VLAN ID – Management = 65535 will accept untagged management frames from the Ethernet port. From the wireless port it will accept only tagged frames with a VLAN ID tag that matches the defined Service Provider VLAN ID.
- Management frames generated by the unit are not tagged.

The following table summarizes the functionality of the internal management port in accordance with the value of the VLAN ID-Management parameter. The table is valid for all link types. Refer to the VLAN Link Type - Access Link, Trunk Link and Service Provider Link options for some restrictions when configuring this parameter.

<b>Action</b>	<b>Management Port - Internal</b>
Receive from Ethernet when Link Type is Access, Trunk or Hybrid	Tagged frames, matching VID-M Untagged frames when VID-M=65535
Receive from Ethernet when Link Type is Service Provider	Tagged frames, matching VID-M
Receive from Wireless when Link Type is Access, Trunk or Hybrid	Tagged frames, matching VID-M Untagged frames when VID-M=65535
Receive from wireless when Link Type is Service Provider	Tagged frames, matching VID-M
Transmit	Insert VID-M, PID-M

**Table Legend:**

- **VID-M:** VLAN ID-Management
- **PID-M:** VLAN Priority-Management

#### 4.2.6.4.1.3 VLAN Link Type

The VLAN Link Type parameter enables defining the functionality of the VLAN aware capability of the unit.

The available options are Hybrid Link, Trunk Link, Access Link and Service Provider Link (Access Link option is available only in SUs).

The default selection is Hybrid Link.

##### 4.2.6.4.1.3.1 Access Link (SU only)

Access Link transfers frames while tagging/untagging them since all devices connected to the unit are VLAN unaware. Thus, the unit cannot transfer tagged frames.

Table 4-7 summarizes the functionality of the data port for an Access link.

<b>Action</b>	<b>Data Port - SU</b>
Receive from Ethernet	Untagged frames
Accept from Wireless	Tagged frames, matching VID-D
Tag Insert	VID-D, PID-D (to wireless)
Tag Remove	Yes (to Ethernet)

**Table Legend:**

- VID-D: VLAN ID-Data
- PID-D: VLAN Priority-Data

**4.2.6.4.1.3.2 Trunk Link**

Trunk Link transfers only tagged frames, as all devices connected to the unit are VLAN aware. Only tagged data frames received on the Ethernet or wireless link ports are forwarded.

**CAUTION**

It is not recommended that you configure a unit as a Trunk Link with the VLAN ID-Management parameter set at 65535, as it does not forward any 'NO VLAN' management frames to its other port, making it impossible to manage devices connected behind the unit that are also configured with 'NO VLAN'.

If the VLAN Forwarding option is enabled, a data frame received with a VLAN ID that is not a member of the unit's VLAN Forwarding List is discarded.

**NOTE**

If the **VLAN Forwarding** option is enabled, be sure to include the **VLAN ID-Management** value of all units that should be managed via the wireless port of the unit, in the Forwarding List.

If the VLAN Relaying option is enabled in an AU, a data frame relayed with a VLAN ID that is not a member of the unit's VLAN Relaying List is discarded.

**NOTE**

If the **VLAN Relaying** option is enabled and you manage your devices from behind an SU unit, be sure to include the **VLAN ID-Management** value of all units to be managed when relaying via the wireless port of the AU unit, in the Relaying List. If the VLAN Forwarding option is also enabled in the AU, these VLAN IDs should also be included in the Forwarding List.

Table 4-8 summarizes the functionality of the data port for a Trunk link.

<b>Table 4-8: VLAN Data Port Functionality - Trunk Link</b>	
<b>Action</b>	<b>Data Port – AU and SU</b>
Accept from Ethernet	Tagged frames. If Forwarding is enabled, only frames with VLAN ID values which are included in the Forwarding list
Accept from Wireless	Tagged frames If Forwarding is enabled, only frames with VLAN ID values which are included in the Forwarding list
Tag Insert	No
Tag Remove	No

#### 4.2.6.4.1.3.3 Hybrid Link

Hybrid Link transfers both tagged and untagged frames, as the devices connected to the unit can be either VLAN aware or VLAN unaware. This is equivalent to defining no VLAN support, as the unit is transparent to VLAN.

Table 4-9 summarizes the functionality of the data port for a Hybrid link.

<b>Table 4-9: VLAN Data Port Functionality - Hybrid Link</b>	
<b>Action</b>	<b>Data Port – AU and SU</b>
Accept from Ethernet	All
Accept from Wireless	All
Tag Insert	No
Tag Remove	No

### 4.2.6.4.1.3.4 Service Provider Link

A Service Provider Link transfers both single tagged frames (Service Provider tag) and double-tagged frames (Service Provider tag + Customer tag). The Service Provider tag includes the Service Provider VLAN ID and the VLAN QinQ Ethertype.

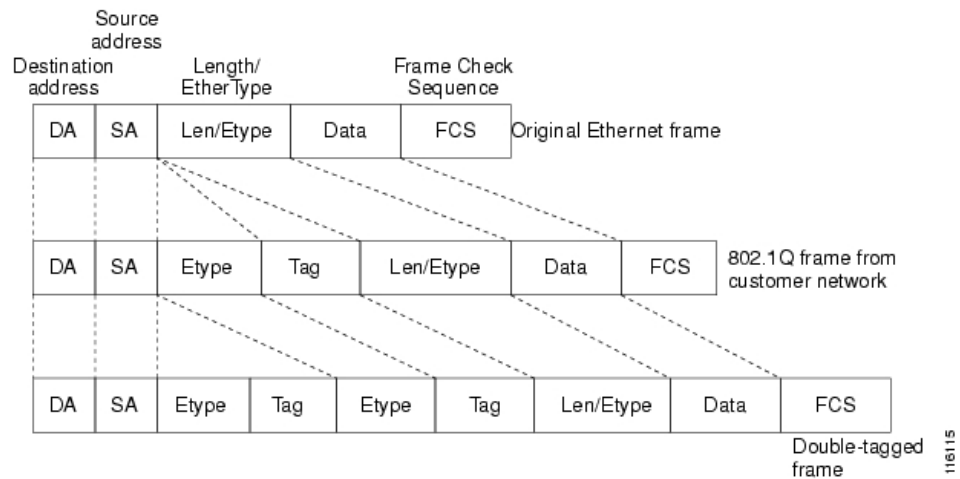

The following tables summarize the functionality of the SU/AU data port for a Service Provider Link.

<b>Action</b>	<b>Data Port –SU</b>
Accept from Ethernet	Untagged frames Single tagged frames: <ul style="list-style-type: none"> <li>■ If Forwarding is disabled</li> <li>■ If Forwarding is enabled, only frames with VLAN ID values which are included in the Forwarding List</li> </ul>
Accept from Wireless	Single tagged frames: only frames with a Service Provider tag whose parameters match the Service Provider parameters defined in the unit (Service Provider VLAN ID and VLAN QinQ Ethertype) Double tagged frames: only frames with a Service Provider tag whose parameters match the Service Provider parameters defined in the unit (Service Provider VLAN ID and VLAN QinQ Ethertype). If Forwarding is enabled, only frames with Customer VLAN ID values that are included in the Forwarding List
Tag Insert	Service Provider (SP) tag (to wireless)
Tag Remove	Yes (to Ethernet)

<b>Table 4-11: VLAN Data Port Functionality for AU - Service Provider Link</b>	
<b>Action</b>	<b>Data Port –AU</b>
Accept from Ethernet	Single tagged frames: <ul style="list-style-type: none"> <li>■ If Forwarding is disabled</li> <li>■ If Forwarding is enabled, only frames with VLAN ID values which are included in the Forwarding List</li> </ul> Double tagged frames: <ul style="list-style-type: none"> <li>■ If Forwarding is disabled</li> <li>■ If Forwarding is enabled, only frames with Service Provider VLAN ID values which are included in the Forwarding List</li> </ul>
Accept from Wireless	Single tagged frames: <ul style="list-style-type: none"> <li>■ If Forwarding is disabled</li> <li>■ If Forwarding is enabled, only frames with VLAN ID values which are included in the Forwarding List</li> </ul> Double tagged frames: <ul style="list-style-type: none"> <li>■ If Forwarding is disabled</li> <li>■ If Forwarding is enabled, only frames with Service Provider VLAN ID values which are included in the Forwarding List</li> </ul>
Tag Insert	No
Tag Remove	No

**NOTE**

The following units management limitations apply when using a Service Provider Link:

- The unit can be managed only with tagged frames: VLAN ID – Management must be other than 65535.
- To enable proper management, all units in a cell (the AU and all SUs served by it) must use the VLAN ID - Management.
- The VLAN ID – Management must differ from the Customer's VLAN ID - Data.

#### 4.2.6.4.1.4 VLAN Forwarding (AU and SU)

The VLAN Forwarding feature is applicable only for Trunk Links and Service Provider Links. It enables defining the VLAN ID values to be included in the VLAN Forwarding List. If the Link Type is defined as either a Trunk Link or a Service Provider Link and the VLAN Forwarding option is enabled, a data frame received with a VLAN ID (or a Service Provider VLAN ID) that is not a member of the unit's VLAN Forwarding List is discarded.

The VLAN Forwarding submenu provides the following options:

#### 4.2.6.4.1.4.1 VLAN Forwarding Support

The VLAN Forwarding Support option enables or disables the VLAN Forwarding feature.

Available selections are Disable and Enable.

The default selection is Disable.

#### 4.2.6.4.1.4.2 Add Forwarding VLAN ID

The Add Forwarding VLAN ID option enables adding a VLAN ID to the VLAN Forwarding List. One VLAN ID can be entered at a time. The maximum number of VLAN IDs in the VLAN Forwarding List is 20.

Valid values are 1 to 4094.

#### 4.2.6.4.1.4.3 Remove Forwarding VLAN ID

The Remove Forwarding VLAN ID option enables removing a VLAN ID from the VLAN ID Forwarding List.

Valid values are VID values (from 1 to 4094) that are included in the VLAN Forwarding List.

#### 4.2.6.4.1.4.4 Show VLAN ID Forwarding List

The Show VLAN Forwarding List option displays the values of the VLAN IDs included in the VLAN Forwarding List.

#### NOTE



If the VLAN ID Forwarding List is empty and the VLAN Forwarding Support is set to Enable, then all data frames are discarded.

If VLAN Relaying Support and VLAN Forwarding Support are both enabled, then all VLAN IDs configured in the Relaying List must also be configured in the Forwarding List.

#### 4.2.6.4.1.5 VLAN Relaying (AU only)

The VLAN Relaying feature is applicable only for Trunk Links and Service Provider Links. It enables defining the VLAN ID values to be included in the VLAN Relaying List.

If the Link Type is defined as either a Trunk Link or a Service Provider Link and the VLAN Relaying Support option is enabled, a frame relayed from the wireless link, which is a frame received from the wireless link that should be transmitted back through the wireless link, with a VLAN ID (or a Service Provider VLAN ID) that is not a member of the unit's VLAN Relaying List, is discarded. If VLAN Forwarding Support is also enabled, it is necessary to configure all the VLAN IDs in the Relaying List also in the Forwarding List to enable the relaying operation.

The VLAN Relaying menu provides the following options:

#### 4.2.6.4.1.5.1 VLAN Relaying Support

The VLAN Relaying Support option enables or disables the VLAN Relaying feature.

Available selections are Disable and Enable.

The default selection is Disable.

#### 4.2.6.4.1.5.2 Add Relaying VLAN ID

The Add Relaying VLAN ID option enables adding a VLAN ID to the VLAN Relaying List. One VLAN ID can be entered at a time. The maximum number of VLAN IDs in the VLAN Relaying List is 20.

Valid values are 1 to 4094.

#### 4.2.6.4.1.5.3 Remove Relaying VLAN ID

The Remove Relaying VLAN ID option enables removing a VLAN ID from the VLAN ID Relaying List. Valid values are VID values (from 1 to 4094) that are included in the VLAN Relaying List.

#### 4.2.6.4.1.5.4 Show VLAN ID Relaying List

The Show VLAN Relaying option displays the values of the VLAN IDs included in the VLAN Relaying List.



#### NOTE

If the VLAN ID Relaying List is empty and the VLAN Relaying Support is Enabled, then all data frames relayed from the wireless link are discarded.

If VLAN Relaying Support and VLAN Forwarding Support are both enabled, then all VLAN IDs configured in the Relaying List must also be configured in the Forwarding List.

#### 4.2.6.4.1.6 Service Provider VLAN ID (SU only)

The Service Provider VLAN ID is applicable only when the VLAN Link Type parameter is set to Service Provider Link. It enables defining the Service Provider VLAN ID for data frames, which identifies the Service Provider VLAN to which the unit belongs.

The range is 1 to 4094.

The default value is 1.

The Service provider VLAN ID affects frames received from the wireless link port, as follows:

- Both single-tagged frames (having Service Provider VLAN ID tag) and double-tagged frames (having Service Provider VLAN ID and customer VLAN ID tags) with matching VLAN ID are forwarded to the Ethernet Port (provided the Ethertype of the tag matches the configured VLAN QinQ Ethertype).

- Before transmitting the frames to the Ethernet port, the Service Provider VLAN ID tag is removed.

The Service Provider VLAN ID affects frames received from the Ethernet link port, as follows: A Service Provider tag, that includes the configured Service Provider VLAN ID (and the VLAN QinQ Ethertype) is inserted in all frames, both tagged and untagged, before transmission to the wireless link.

#### 4.2.6.4.1.7 VLAN Traffic Priority

The VLAN Traffic Priority menu enables configuring the VLAN Priority field in applicable frames. These parameters only impact the way in which other VLAN aware devices in the network will handle the packet. All parameters that affect prioritization within the BreezeACCESS VL system, including VLAN-based prioritization, are located in the Traffic Prioritization menu.

The VLAN Traffic Priority menu includes the following parameters:

- VLAN Priority – Data (SU only)
- VLAN Priority – Management

##### 4.2.6.4.1.7.1 VLAN Priority - Data (SU only)

The VLAN Priority - Data is applicable for Access Links only. It enables configuring the value of the VLAN Priority field for data frames transmitted to the wireless link. All data frames are routed to the Low queue. This parameter only impacts the way other VLAN aware devices handle the packet.

Valid values range from 0 to 7.

The default value is 0.

##### 4.2.6.4.1.7.2 VLAN Priority - Management

The VLAN Priority - Management enables defining the value of the VLAN Priority field for management frames in units with VLAN ID-Management that is other than **65535**. All management frames are routed to the High queue. This parameter only impacts the way other VLAN aware devices handle the packet.

Valid values range from 0 to 7.

The default value is 4 for SUs and 0 for AUs.

##### 4.2.6.4.1.8 VLAN QinQ Protocol Ethertype

The VLAN QinQ Protocol Ethertype parameter sets the Ethertype of the Service Provider tag, and is applicable only for Service Provider Links.

The valid values are from 8100 to 9000, 9100 and 9200 (Hex).

The default value is 8100 (Hex).

#### 4.2.6.4.1.9 Show VLAN Parameters

The Show VLAN Parameters option displays the current values of the VLAN support parameters.

#### 4.2.6.4.2 Ethernet Broadcast Filtering (SU only)

The Ethernet Broadcast Filtering menu enables defining the layer 2 (Ethernet) broadcast and multicast filtering capabilities for the selected SU. Filtering the Ethernet broadcasts enhances the security of the system and saves bandwidth on the wireless medium by blocking protocols that are typically used in the customer's LAN but are not relevant for other customers, such as NetBios, which is used by the Microsoft Network Neighborhood. Enabling this feature blocks Ethernet broadcasts and multicasts by setting the I/G bit at the destination address to 1. This feature should not be enabled when there is a router behind the SU.

The Ethernet Broadcast Filtering menu includes the following parameters:

- Filter Options
- DHCP Broadcast Override Filter
- PPPoE Broadcast Override Filter
- ARP Broadcast Override Filter

##### 4.2.6.4.2.1 Filter Options

The Filter Options enables defining the Ethernet Broadcast filtering functionality of the unit. Select from the following options:

- **Disable** - no Ethernet Broadcast Filtering.
- **On Ethernet Port Only** - filters broadcast messages received from the Ethernet port.
- **On Wireless Port Only** - filters broadcast messages received from the wireless link port.
- **On Both Ethernet and Wireless Ports** - filters broadcast messages received from both the Ethernet and wireless link ports.

The default selection is Disable.

#### 4.2.6.4.2.2 DHCP Broadcast Override Filter

The DHCP Broadcast Override Filter option enables or disables the broadcasting of DHCP messages. Even if according to the selected option in the Filter Options parameter, broadcast messages should be filtered, DHCP broadcasts are transmitted if this parameter is set to Enable. Select from the following options:

- **Disable** - DHCP Broadcast messages are filtered or transmitted according to the general filtering criteria in the Filter Options parameter.
- **Enable** - DHCP Broadcast messages are transmitted regardless of the selected value of the Filter Options parameter.

The default selection is Disable.

#### 4.2.6.4.2.3 PPPoE Broadcast Override Filter

The PPPoE Broadcast Override Filter option enables or disables the broadcasting of PPPoE (Point to Point Protocol over Ethernet) messages. Even if according to the selected option in the Filter Options parameter, broadcast messages should be filtered, PPPoE broadcasts are transmitted if this parameter is set to Enable. Select from the following options:

- **Disable** - PPPoE Broadcast messages are filtered or transmitted according to the general filtering criteria in the Filter Options parameter.
- **Enable** - PPPoE Broadcast messages are transmitted regardless of the selected value of the Filter Options parameter.

The default selection is Disable.

#### 4.2.6.4.2.4 ARP Broadcast Override Filter

The ARP Broadcast Override Filter option enables or disables the broadcasting of ARP messages. Even if according to the selected option in the Filter Options parameter, broadcast messages should be filtered, ARP broadcasts are transmitted if this parameter is set to Enable. Select from the following options:

- **Disable** - ARP messages are filtered or transmitted according to the general filtering criteria in the Filter Options parameter.
- **Enable** - ARP messages are transmitted regardless of the selected value of the Filter Options parameter.

The default selection is Enable.

#### 4.2.6.4.3 Ethernet Broadcast/Multicast Limiter

The Ethernet Broadcast/Multicast Limiter parameters, available in both AU and SU, enable to limit the number of broadcast and/or multicast packets that can be transmitted per second, in order to prevent the potential flooding of the wireless medium by certain ARP attacks.

In SUs, the limiter is placed after the Ethernet Broadcast Filters. For this reason, the limiter will receive only the packets that pass through these filters. If the Ethernet filters of the SU are disabled, the limiter will be applied to all relevant packets received.

When the Ethernet Broadcast/Multicast Limiter is enabled and the specified limit is reached, the unit will send a trap. The trap will be sent periodically till the number of broadcast/multicast packets will be less than the maximum. The trap will inform the user how many packets were discarded in the last period.

The Ethernet Broadcast/Multicast Limiter menu allows viewing and setting the following parameters:

##### 4.2.6.4.3.1 Ethernet Broadcast/Multicast Limiter Option

The Ethernet Broadcast/Multicast Limiter Option defines the limiter's functionality. The available options are:

- Disable: No limiter
- Limit only Broadcast Packets
- Limit Multicast Packets that are not Broadcasts
- Limit All Multicast Packets (including broadcast)

The default selection is Disable.

##### 4.2.6.4.3.2 Ethernet Broadcast/Multicast Limiter Threshold

The Ethernet Broadcast/Multicast Limiter Threshold defines the maximum number of packets per second that will pass the limiter when it is enabled.

The range is from 0 to 204800 (packets/second).

The default is 50 packets.

##### 4.2.6.4.3.3 Ethernet Broadcast/Multicast Limiter Send Trap Interval

The Ethernet Broadcast/Multicast Limiter Send Trap Interval defines the minimum time in minutes between two consecutive transmissions of the trap indicating the number of packets that were dropped by the limiter since the previous trap (or since the time that the limit has been exceeded).

The range is from 1 to 60 minutes.

The default is 5 minutes.

#### 4.2.6.4.4 Bridge Aging Time

The Bridge Aging Time parameter enables selecting the bridge aging time for learned addresses of devices on both the wired and wireless sides, not including BreezeACCESS VL units.

The available range is 20 to 2000 seconds.

The default value is 300 seconds.

#### 4.2.6.4.5 Broadcast/Multicast Relaying (AU only)

The Broadcast/Multicast Relaying option enables selecting whether the unit performs relaying of broadcasts and/or multicasts.

The available options are:

- Disable
- Broadcast/Multicast Enable
- Broadcast Enable
- Multicast Enable

If broadcast/multicast relaying is disabled, these packets are sent only to the local wired LAN and are not sent back to the wireless link. When broadcast and/or multicast relaying is enabled, the relevant packets (broadcasts only, multicasts only or both broadcasts and multicasts) originating from devices on the wireless link are transmitted by the AU back to the wireless link devices, as well as to the wired LAN.

The default selection is Broadcast/Multicast Enable.

#### 4.2.6.4.6 Unicast Relaying (AU only)

The Unicast Relaying option enables selecting whether the unit performs unicast relaying. When the Unicast Relaying parameter is enabled, unicast packets originating from devices on the wireless link can be transmitted back to the wireless link devices. If disabled, these packets are not sent to the wireless link even if they are intended for devices on the wireless link. Disable the Unicast Relaying parameter only if all unicast messages from the wireless link are certain to be directed to the local wired LAN.

The default selection is Enable.

#### 4.2.6.4.7 MAC Address List (AU only)

The MAC Address List submenu enables to define a list of up to 100 MAC addresses as belonging to devices that are either granted or denied service. When the list is defined as a Deny List, the AU will not provide services to a unit whose MAC address is included in the list, enabling to disconnect units in cases such as when the user had fraudulently succeeded to configure the unit to values different from the subscription plan. When the list is defined as an Allow List, the AU will provide services only to units with a MAC address that is included in the list.

In addition, the Station Allowed Option enables defining whether an SU with any MAC address can try to associate with the AU, or only SUs with a MAC address starting with 00-10-E7 (the supplier's MAC addresses range).

The MAC Address List submenu includes the following:

##### 4.2.6.4.7.1 Add MAC Address to List

Select Add MAC Address to List to add a MAC Address to the List.

##### 4.2.6.4.7.2 Remove MAC Address from List

Select Remove MAC Address from List to remove a MAC Address from the List.

##### 4.2.6.4.7.3 MAC Address List Action

This parameter defines the working mode of the MAC list:

- In the case of an Allowed list, if the MAC address is included in the list, the SU will be able to associate itself with the AU and receive permission for generating traffic; if it is not found in the list, it will still be associated but without the permission to generate traffic.
- In the case of a Deny list, if the MAC address is included in the list, the SU will be able to associate itself with the AU but will not be able to generate traffic; otherwise (if the address is not found in the list) the SU will be associated and will be able to generate traffic.

Possible options for this parameter are Deny and Allow.

The default is Deny.

##### 4.2.6.4.7.4 Station Allowed Option

Set this parameter to Enable to allow any SU (regardless of its' MAC address to try associating with the AU). Set it to Disable to allow only SUs whose MAC address starts with 00-10-E7 to try associating with the AU.

The default is Enabled.

#### 4.2.6.4.7.5 Show MAC Address List

Select Show MAC Address List to display the current list of MAC Addresses included in the List and the selected List Action.

#### 4.2.6.4.8 Roaming Option (SU only)

The Roaming Option defines the roaming support of the unit. When roaming is not expected, it is preferable to set this parameter to Disable. This will cause the unit to start scanning for another AU after losing connectivity with the current AU only after 7 seconds during which no beacons were received from the current AU. This will prevent scanning for another AU in cases where no beacons were received due to a short temporary problem.

When set to Enable, the SU will wait only one second before it starts scanning for another AU. In addition, when the Roaming Option is enabled, the SU will send Roaming SNAP messages upon associating with a new AU. This enables fast distribution of the new location for all clients that are behind the SU. In this case, the SU will send multicast SNAP messages via the wireless link each time it associates with a new AU, except for the first association after reset. The SU will send one SNAP message for each client learned on its Ethernet port, based on its bridging table. In the SNAP message the clients' MAC address is used as the source address. The AU that receives this SNAP message learns from it the new location of the clients. It forwards the SNAP to other AUs and Layer-2 networking equipment via its Ethernet port, to facilitate uninterrupted connectivity and correct routing of transmissions to these clients. The new AU as well as the previous AU with which the SU was associated, will forward the SNAP messages to all other SUs associated with them.

The default is Disable.

#### 4.2.6.4.9 Ports Control (SU only)

The Ports Control sub-menu includes the Ethernet Port Control option:

##### 4.2.6.4.9.1 Ethernet Port Control

The Ethernet Port Control option allows enabling or disabling non-management traffic to/from the Ethernet port. When changed to Disable, all current data sessions will be terminated. The unit is still manageable via the Ethernet port even if it is disabled for data traffic.

The default selection is Enable.

#### 4.2.6.4.10 Show Bridge Parameters

The Show Bridge Parameters option displays the current values of the Bridge parameters.

## 4.2.6.5 Performance Parameters

The Performance Parameters menu enables defining a series of parameters that control the method by which traffic is transmitted through the wireless access network.

The Performance Parameters menu includes the following parameters:

- RTS Threshold
- Minimum Contention Window
- Maximum Contention Window
- Multicast Modulation Level (AU only)
- Maximum Modulation Level
- Average SNR Memory Factor
- Number of HW Retries
- Burst Mode
- Adaptive Modulation Algorithm
- Concatenation Parameters

### 4.2.6.5.1 RTS Threshold

The RTS Threshold parameter defines the minimum frame size that requires an RTS/CTS (Request To Send/Clear To Send) handshake. Frames whose size is smaller than the RTS Threshold value are transmitted directly to the wireless link without being preceded with RTS frames. Setting this parameter to a value larger than the maximum frame size eliminates the RTS/CTS handshake for frames transmitted by this unit.

The available values range from 20 to 4092 bytes for units with HW revision C or higher, and 20 to 2200 for units with HW revision A or B.

The default value for SUs is 60 bytes.

For AUs with HW revision C or higher, the default is 4092, and for AUs with HW revision A or B the default is 2200. It is recommended that these values be used to ensure that RTS/CTS is never used in the AU. Minimum Contention Window

The Minimum Contention Window parameter determines the time that a unit waits from the time it has concluded that there are no detectable transmissions by other units until it attempts to transmit. The BreezeACCESS VL system uses a special mechanism based on detecting the presence of a carrier signal and analyzing the information contained in the transmissions of the AU to estimate the activity of other SUs served by the AU. The target is to minimize collisions in the wireless medium resulting from attempts of more than one unit to transmit at the same time.

The system uses an exponential Back-off algorithm to resolve contention between several units that want to access the wireless medium. The method requires each station to choose a random number N between 0 and a given number C each time it wants to access the medium. The unit will attempt to access the medium only after a time equal to DIFS (for more details refer to section [4.2.6.2.11](#)) plus N time slots, always checking if a different unit has accessed the medium before. Each time the unit tries to transmit and a collision occurs; the maximum number C used for the random number selection will be increased to the next available value. The available values are 7, 15, 31, 63, 127, 255, 511 and 1023.

The Minimum Contention Window parameter is the first maximum number C used in the back-off algorithm. The higher the number of SUs served by the same AU, the higher the Minimum Contention Window for each SU should be. In addition, when the Wireless Link Prioritization Option is enabled, the Minimum and Maximum Contention Window parameters can be configured to provide certain units with an advantage over other units.

The available values are 0, 7, 15, 31, 63, 127, 255, 511 and 1023. A value of 0 means that the contention window algorithm is not used and that the unit will attempt to access the medium immediately after a time equal to DIFS.

The default value is 15.

#### CAUTION



A value of 0 disables the contention window back-off algorithm. It should only be used in point-to-point applications. For more details on configuring units in a point-to-point link refer to section [4.2.6.2.11](#).

#### 4.2.6.5.2 Maximum Contention Window

The Maximum Contention Window parameter defines the upper limit for the maximum number C used in the back-off algorithm as described in Minimum Contention Window above.

The available values are 7, 15, 31, 63, 127, 255, 511 and 1023.

The default value is 1023.

#### 4.2.6.5.3 Multicast Modulation Level (AU only)

The Multicast Modulation Level parameter defines the modulation level used for transmitting multicast and broadcast data frames. Multicast and broadcast transmissions are not acknowledged; therefore if a multicast or broadcast transmission is not properly received there is no possibility of retransmitting. It is recommended that you set a lower modulation level for broadcast and multicast frame transmissions to increase the probability that they are received without errors.

The Multicast Modulation Level parameter is applicable only to data frames. Beacons and other wireless management and control frames are always transmitted at the lowest modulation level according to the Sub-Band.

The minimum and maximum values for the Multicast Modulation Level are defined by the Sub-Band in use. For information on how to view the Sub-Bands supported by the unit and the supported parameters' values and options, refer to section [4.2.2.4](#). Currently, all Sub Bands support the entire range of modulation levels, from 1 to 8. However, the highest modulation level supported by units with HW revision A is modulation level 7.

The default value is the lowest supported modulation level (modulation level 1).

#### 4.2.6.5.4 Maximum Modulation Level

When the Adaptive Modulation Algorithm (see section [4.2.6.5.8](#)) is enabled, it changes the modulation level dynamically according to link conditions. The purpose is to increase the probability of using the maximum possible modulation level at any given moment. Although the algorithm will avoid using modulation levels that are too high for the prevailing link conditions, it might be better under certain conditions to limit the use of higher modulation levels. If the link quality is not sufficient, it is recommended that the maximum modulation level be decreased, as higher modulation levels increase the error rate. In such conditions, a higher Maximum Modulation Level increases the number of retransmissions before the modulation level is being reduced by the Adaptive Modulation Algorithm. A high number of retransmissions reduces the overall throughput of the applicable SU as well as all other SUs associated with the same AU.

The link quality can be estimated based on the SNR measurement of the SU at the AU, which can be viewed in the MAC Address Database option in the Site Survey menu. If the measured SNR is less than a certain threshold, it is recommended that the maximum modulation level of the SU be decreased in accordance with Table 4-12, using the values of typical sensitivity. It is recommended to add a 2 dB safety margin to compensate for possible measurement inaccuracy or variance in the link quality.

**NOTE**

The SNR measurement at the AU is accurate only when receiving transmissions from the applicable SU. If necessary, use the Ping Test utility in the Site Survey menu to verify data transmission.

When the Adaptive Modulation Algorithm is disabled, this parameter will serve to determine Fixed Modulation Level used for transmissions.

The minimum and maximum values for the Maximum Modulation Level are defined by the Sub-Band in use. For information on how to view the Sub-Bands supported by the unit and the supported parameters' values and options, refer to section [4.2.2.4](#). Currently, all Sub Bands support the entire range of modulation levels, from 1 to 8. However, the highest modulation level supported by units with HW revision A is modulation level 7.

VL 900 SUs with HW revision F use a default maximum modulation level of 5. For the rest of the units, the default is the highest supported modulation level (8 for all units with HW revision B or higher, 7 for units with HW revision A).

<b>Table 4-12: Recommended Maximum Modulation Level*</b>	
<b>SNR</b>	<b>Maximum Modulation Level</b>
SNR > 23 dB	8
21 dB < SNR < 23 dB	7
16 dB < SNR < 21 dB	6
13 dB < SNR < 16 dB	5
10 dB < SNR < 13 dB	4
8 dB < SNR < 10 dB	3
7 dB < SNR < 8 dB	2
6 dB < SNR < 7 dB	1

\* The maximum supported value depends on the unit's HW revision and on the Max Modulation Level according to the Sub-Band.

#### 4.2.6.5.5 Average SNR Memory Factor

The Average SNR Memory Factor defines the weight of history (value of last calculated average SNR) in the formula used for calculating the current average SNR for received data frames. This average SNR is used by the ATPC algorithm in the AU and is also included in the Adaptive Modulation Algorithm information messages transmitted by the AU and the SU. The higher the value of this parameter, the higher is the weight of history in the formula.

Available values: -1 to 32. -1 is for no weight for history, meaning that average SNR equals the last measured SNR.

Default value: 5

#### 4.2.6.5.6 Number of HW Retries

The Number of HW Retries parameter defines the maximum number of times that an unacknowledged packet is retransmitted. When the Adaptive Modulation Algorithm is disabled, a frame will be dropped when the number of unsuccessful retransmissions reaches this value. For details on the effect of this parameter when the Adaptive Modulation Algorithm is enabled, refer to section [4.2.6.5.8](#).

#### NOTE



The Number of HW Retries parameter is not applicable when the Wireless Link Prioritization Option is enabled.

The available values range is from 1 to 14.

The default value is 10.

#### 4.2.6.5.7 Burst Mode

Burst mode provides an increased throughput by reducing the overhead associated with transmissions in the wireless medium. In a burst transmission the inter-frame spacing is reduced and unicast data frames are transmitted without any contention period (burst mode is not activated on broadcasts/multicasts).

The Burst Mode is available only if Burst Mode is supported by the Sub-Band in use. For information on how to view the Sub-Bands supported by the unit and the supported parameters' values and options, refer to section [4.2.2.4](#).

In AUs with HW Revision B or lower, Burst Mode cannot be activated when DFS is used. In AUs with HW Revision B or lower, the Burst Mode option will be “blocked” upon trying to enable Burst Mode when DFS is enabled. This limitation does not apply to AUs with HW Revision C.

In SUs and AUs with HW Revision B or lower, Burst Mode cannot be activated when using WEP for data encryption. In units with HW Revision B or lower, the Burst Mode option will be “blocked” upon trying to enable it when using WEP for data encryption. This limitation does not apply to units with HW Revision C.

#### NOTE



The Burst Mode parameters are not applicable when the Wireless Link Prioritization Option is enabled.

##### 4.2.6.5.7.1 Burst Mode Option

The Burst Mode Option enables or disables the Burst Mode operation.

The default is Enable.

#### 4.2.6.5.7.2 Burst Mode Time Interval

The Burst Mode Time Interval defines the burst size, which is the time in which data frames are sent immediately without contending for the wireless medium.

The range is 1 to the value of the Maximum Burst Duration defined for the Sub-Band.

The default is 5 milliseconds or the value of Maximum Burst Duration defined for the Sub-Band (the lower of the two values).

#### 4.2.6.5.8 Adaptive Modulation

The Adaptive Modulation algorithm enables adapting the modulation level of transmitted data to the prevailing conditions of the applicable radio link. The algorithm provides Access Units with simultaneous, adaptive support for multiple Subscriber Units at different modulation levels, as transmission's modulation level decisions are made separately for each associated SU.

Link quality fluctuates due to various environmental conditions. Dynamically switching between the possible modulation levels increases the probability of using the maximum modulation level suitable for the current radio link quality at any given moment.

When enabled, the Adaptive Modulation algorithm, constantly evaluates the achievable throughput for a particular modulation by counting the number of packets that are successfully transmitted and the packets that are not received and that need to be retransmitted. Based on these statistics, and on each modulation's specific data rate, it will calculate the real throughput that the unit can support in the current conditions for a particular modulation.

When choosing between modulations, up to a limit, a small number of retransmissions on a higher modulation is compensated by the overall better performance ensured by that modulation. When a critical retransmissions percentage is reached however, it is necessary to decrease the modulation to achieve better throughputs as shown in Table 4-13.

**Table 4-13: Retransmission Percentage Equivalence**

<b>Modulation Level</b>	<b>PHY Rate (Mbps)</b>	<b>PHY Rate Difference Compared to Previous Modulation (Mbps)</b>	<b>Retransmission Percentage Equivalent to PHY Rate Difference</b>

Table 4-13: Retransmission Percentage Equivalence

Modulation Level	PHY Rate (Mbps)	PHY Rate Difference Compared to Previous Modulation (Mbps)	Retransmission Percentage Equivalent to PHY Rate Difference
8	54	54-48=6	6/54=11%
7	48	48-36=12	12/48=25%
6	36	36-24=12	12/36=33%
5	24	24-18=6	6/24=25%
4	18	18-12=6	6/18=33%
3	12	12-9=3	3/12=25%
2	9	9-6=3	3/9=33%
1	6		

When the above mentioned retransmission percentages are reached, the Adaptive Modulation algorithm will lower the modulation. If the connection is stable on a particular modulation, the unit will periodically check whether it can further increase the modulation (except on modulation 8), by sending a number of test packets using this higher modulation and checking the retransmission rate.

The user can configure a Packet Threshold to Test Up Rate parameter to define the number of successfully transmitted frames after which the unit will test the higher modulation. The number of frames used for this test can also be configured by the user via the Packet No On Upper Rate parameter.

#### 4.2.6.5.8.1 Adaptive Modulation Option

The Adaptive Modulation Option enables or disables the Adaptive Modulation decision algorithm. When enabled, the algorithm supports decrease/increase of transmission's modulation levels between the lowest possible level to the value configured for the Maximum Modulation Level parameter. If the Maximum Modulation Level is set at the lowest possible level, the Adaptive Modulation algorithm has no effect.

The default selection is Enable.

#### 4.2.6.5.8.2 History Size

This option indicates the number of entries used by the Adaptive Modulation algorithm to compute the transmission time.

The available range is between 15 and 25.

The default value is 15.

#### 4.2.6.5.8.3 Packet Thershold to Test Up Rate

When the number of frames transmitted on the current modulation reaches this number, the Adaptive Modulation algorithm will test the upper modulation.

The available range is between 10 and 10000.

The default value is 100.

#### 4.2.6.5.8.4 Packet No On Upper Rate

This option indicates the number of frames used by the Adaptive Modulation algorithm to test upper modulations.

The available range is between 1 and 3.

The default value is 1.

#### 4.2.6.5.9 Concatenation Parameters

The Concatenation mechanism enables bundling several data frames into a single frame for transmission to the wireless link. This feature improves throughput and reduces the overhead in the wireless medium, by requiring only one CRC for each concatenated frame, one RTS/CTS cycle if applicable, and a single waiting period according to the contention window mechanism before transmission. When concatenation is enabled, data packets in the queue of the internal bridge can be accumulated before the concatenated frame is transmitted to the wireless medium. Data frames can be accumulated up to a maximum frame size of 2200 bytes for units with HW revision A or B, or 4032 bytes for units with HW revision C or higher. In the AU, the concatenation process is performed separately for each destination SU.

#### NOTE



Using the Link Capability exchange mechanism, each unit learns the HW Revision and the SW Version of the unit(s) associated with it. A concatenated frame with a length exceeding 2200 bytes may be generated and transmitted only if both the source and destination units have HW Revision C or higher. If either the source or destination unit uses SW Version 3.0 or 3.1, then the maximum size of the concatenated frame is 3400 bytes, and the maximum number of data frames that can be bundled into a concatenated frame is 2 for units with SW version 3.0 and 8 for units with SW version 3.1.

A frame is a candidate for bundling into a concatenated frame if all the following conditions are met:

- The frame is a data frame
- The destination is an entity behind the destination AU/SU.
- The destination AU/SU can support the feature (uses SW version 3.0 or higher).

When a frame is identified as an eligible candidate for concatenation, it is marked accordingly and will be processed according to the following:

- If there is no concatenated frame designated to the same destination unit in the queue:
  - ◇ If the hardware queue is empty – the frame is transmitted immediately.
  - ◇ Otherwise (the queue is not empty) – the frame is inserted to the queue as a concatenated frame.
- If a concatenated frame designated to the same destination unit exists in the queue:
  - ◇ If the combined size of both frames is above the maximum allowed concatenated frame size – both frames are transmitted as two separate frames.
  - ◇ Otherwise (the combined frames size is below the maximum size) – the new frame is added to the concatenated frame. If the number of data frames in the concatenated frame has reached the maximum allowed (applicable only if the destination unit uses SW version 3.0 or 3.1) – the concatenated frame will be transmitted to the wireless medium. Otherwise – the concatenated frame remains in the queue (until the hardware queue becomes free).



#### NOTE

When a frame is marked as a candidate for concatenation, it will be transmitted as a concatenated frame. If it is not bundled with another data frame before transmission, it will be a concatenated frame with a single data frame (Concatenated Frame Single). If it is bundled with two or more data frames, it will be a concatenated frame with either double data frames (Concatenated Frame Double) or more data frames (Concatenated Frame More).

The Concatenation Parameters submenu includes:

#### 4.2.6.5.9.1 Concatenation Option

The Concatenation Option enables or disables the concatenation mechanism.

The default is Enable.

#### 4.2.6.5.9.2 Maximum Concatenated Frame Size

The Maximum Concatenated Frame Size parameter defines the maximum size (in bytes) for a concatenated frame.

The range is:

- 256 to 2200 bytes for units with HW revision A or B
- 256 to 4032 bytes for units with HW revision C or higher

The Default values are:

- 2200 for units with HW revision A or B
- 4032 for units with HW revision C or higher

## 4.2.6.6 Service Parameters

The Service Parameters menu enables defining user filtering, MIR/CIR parameters, traffic prioritization parameters and DRAP parameters.

The Service Parameters menu includes the following options:

- User Filtering Parameters (SU only)
- MIR and CIR Parameters
- Traffic Prioritization
- DRAP Parameters (AU only)
- Wireless Link Prioritization (only AU with a license for the feature)

### 4.2.6.6.1 User Filtering Parameters (SU only)

The User Filtering Parameters submenu enables defining the IP addresses of user devices authorized to access the wireless medium for security and/or control purposes. In addition, it can be used to enable the transmission and reception of specific protocol frames. These filtering options do not affect management frames sent to or generated by the unit.

The User Filtering Parameters menu provides the following options:

#### 4.2.6.6.1.1 User Filtering Option

The User Filtering Option disables or enables the User Filtering feature. The following options are available:

- **Disable** - no filtering.
- **IP Protocol Only** - only IP Protocol packets pass.

- **User Defined Addresses Only** - only IP frames from/to IP addresses included in the User Filter Addresses list pass.
- **PPPoE Protocol Only** - only PPPoE messages pass (Ethernet type 0x8863 and 0x8864).

The default selection is Disable.

#### 4.2.6.6.1.2 Set/Change Filter IP Address Range

The Set/Change Filter IP Address Ranges option enables defining/updating up to 8 IP address ranges to/from which IP frames are to pass if the User Defined Addresses Only option is selected in the User Filtering Option parameter.

The default Filter IP Address Range is 0.0.0.0 TO 0.0.0.0 (all 8 ranges).

A range can be defined using a string that includes either a start and end address, in the format “<start address> to <end address>” (example: 192.168.1.1 to 192.168.1.255), or a base address and a mask, in the format “<base address> mask <mask>” (example: 192.168.1.1 mask 255.255.255.0).

#### 4.2.6.6.1.3 Delete Filter IP Address Range

The Delete Filter IP Address Range option enables deleting IP address range entries from the Filter IP Address Ranges list.

#### 4.2.6.6.1.4 Delete All User Filtering Entries

The Delete All User Filtering Entries option enables deleting all entries from the Filter IP Address Ranges list.

#### 4.2.6.6.1.5 DHCP Unicast Override Filter

When user filtering is activated, unicast DHCP messages are filtered out; therefore the unit cannot communicate with the DHCP server. The DHCP Unicast Override Filter option enables to overcome this problem. When enabled, unicast DHCP messages pass, overriding the user filtering mechanism.

The default is Disable DHCP Unicast.

#### 4.2.6.6.1.6 Show User Filtering Parameters

The Show All User Filtering Parameters option displays the current value of the User Filtering Option and the list of User Filtering addresses, subnet masks and ranges.

#### 4.2.6.6.2 MIR and CIR Parameters

The CIR (Committed Information Rate) specifies the minimum data rate guaranteed to the relevant subscriber. The MIR (Maximum Information Rate) value specifies the maximum data rate available for burst transmissions, provided such bandwidth is available.

Under normal conditions, the actual Information Rate (IR) is between the applicable CIR and MIR values, based on the formula  $IR = CIR + K(MIR - CIR)$ .

In this formula K is between 0 and 1 and is determined dynamically by the AU according to overall demand in the cell and the prevailing conditions that influence the performance of the wireless link. In some situations the minimum rate (CIR) cannot be provided. This may result from high demand and poor wireless link conditions and/or high demand in over-subscribed cells. When this occurs, the actual information rate is lower than the CIR, and  $IR = (1+K)*CIR$ , where  $K < 0$ . The K value to be used in the cell is advertised by the AU in every beacon, and it is changed every second based on comparison of the traffic during the last one second interval with the traffic during the previous previous one second interval. The advertised K value is used by each SU to calculate the amount of data that can be transmitted. This algorithm ensures fair resource distribution among SUs, based on their configured CIR/MIR values.

The MIR Threshold Percent parameter determines the level of wireless link utilization above which the MIR/CIR mechanism is activated. A Threshold of 0% allows CIR only. A threshold of 100% means MIR only. For other values, if the actual wireless link utilization is below the threshold, K is set to 1. As the link utilization increases above the threshold, K is decreased as described above.

The simple solution for managing the information rate in such cases can result in an unfair allocation of resources, as subscribers with a higher CIR actually receive an IR lower than the CIR designated for subscribers in a lower CIR bracket.

A special algorithm for graceful degradation is incorporated into the AU, ensuring that the degradation of performance for each individual Subscriber Unit is proportional to its CIR.

The MIR/CIR algorithm uses buffers to control the flow of data. To balance the performance over time, a special Burst Duration algorithm is employed to enable higher transmission rates after a period of inactivity. If no data intended for a certain SU (in the AU) or for the AU (in an SU) is received from the Ethernet port during the last N seconds, the unit is allowed to transmit to this destination N times its allowed IR value without any delay. For example, if the Burst Duration is set to 0.5 second (or more), then after a period of inactivity of 0.5 seconds up to  $128 \text{ Kbits} \times 0.5 = 64 \text{ Kbits}$  may be transmitted to a unit whose IR is 128 Kbps, without any delay (provided overall conditions in the wireless link allow this burst).

#### 4.2.6.6.2.1 MIR: Downlink (SU only)

Sets the Maximum Information Rate of the downlink from the AU to the SU. The MIR value cannot be lower than the corresponding CIR value.

Available values range and default value are shown in Table 4-14.

The actual value will be the entered value rounded to the nearest multiple of 128 (N\*128).

#### 4.2.6.6.2.2 MIR: Uplink (SU only)

Sets the Maximum Information Rate of the up-link from the SU to the AU. The MIR value cannot be lower than the corresponding CIR value.

Available values range and default value are shown in Table 4-14.

The actual value will be the entered value rounded to the nearest multiple of 128 (N\*128).

#### 4.2.6.6.2.3 CIR: Downlink (SU only)

Sets the Committed Information Rate of the downlink from the AU to the SU. The CIR value cannot be higher than the corresponding MIR value.

Available values range and default value are shown in Table 4-15.

The actual value will be the entered value rounded to the nearest multiple of 128 (N\*128).

#### 4.2.6.6.2.4 CIR: Uplink (SU only)

Sets the Committed Information Rate of the uplink from the SU to the AU. The CIR value cannot be higher than the corresponding MIR value.

Available values range and default value are shown in Table 4-15.

The actual value will be the entered value rounded to the nearest multiple of 128 (N\*128).

Unit Type	MIR Uplink		MIR Downlink	
	Range (Kbps)	Default (Kbps)	Range (Kbps)	Default (Kbps)
SU-3	128-2,048	2,048	128-3,072	3,072
SU-6	128-4,096	4,096	128-6,016	6,016
SU-8	128-13,440	13,440	128-13,440	13,440
SU-54	128-53,888	53,888	128-53,888	53,888
SU-I	128-4,096	4,096	128-6,016	6,016

	<b>CIR Uplink</b>		<b>CIR Downlink</b>	
<b>Unit Type</b>	<b>Range (Kbps)</b>	<b>Default (Kbps)</b>	<b>Range (Kbps)</b>	<b>Default (Kbps)</b>
SU-3	0-2,048	0	0-2,048	0
SU-6	0-4,096	0	0-4,096	0
SU-8	0-11,264	0	0-11,264	0
SU-54	0-45,056	0	0-45,056	0
SU-I	0-4,096	0	0-6,016	0

#### 4.2.6.6.2.5 Maximum Burst Duration (SU and AU)

Sets the maximum time for accumulating burst transmission rights according to the Burst Duration algorithm.

Available values range from 0 to 2000 (milliseconds).

The default value is 5 (milliseconds), enabling a maximum burst of (0.005 X CIR) Kbps after a period of inactivity of 5 milliseconds or more.

#### 4.2.6.6.2.6 Maximum Delay (SU only)

Sets the maximum permitted delay in the buffers system. As certain applications are very sensitive to delay, if relatively high delays are permitted, these applications may suffer from poor performance due to data accumulation in the buffers from other applications, such as FTP. The Maximum Delay parameter limits the number of available buffers. Data that is delayed more than the permitted maximum delay is discarded. If the SU supports applications that are very sensitive to delay, the value of the Maximum Delay should be decreased.

Valid values range from 300 to 10000 (milliseconds).

The default value is 5000 (milliseconds).

#### 4.2.6.6.2.7 Graceful Degradation Limit (AU only)

Sets the limit on using the graceful degradation algorithm. In cases of over demand, the performance of all SUs is degraded proportionally to their CIR ( $IR = (100\% - k\%) \times CIR$ ). The graceful degradation algorithm is used as long as  $k \leq K$ , where  $K$  is the Graceful Degradation Limit. Beyond this point the simple "brute force" algorithm is used. The Graceful Degradation Limit should be raised in proportion to the demand in the cell. The higher the expected demand in a cell, the higher the value of the Graceful Degradation Limit. Higher demand can be expected in cases of significant oversubscription and/or in deployments where a

high number of subscribers are in locations without proper communication with the AU at the highest data rate.

The available values range from 0 to 70 (%).

The default value is 70 (%).

#### 4.2.6.6.2.8 MIR Only Option (AU only)

When the MIR Only Option is enabled, it forces the MIR/CIR algorithm to use MIR values only. The MIR/CIR algorithm determines the actual information rate for each of the supported SUs under changing conditions of demand, based on the configured CIR and MIR values. When the MIR Only Option is enabled, the MIR/CIR algorithm is overridden and forced to operate with MIR values only. For example, the AU attempts to enable all SUs to transmit/receive information at the specified MIR value. When enabled, the graceful degradation algorithm, which is a part of the CIR/MIR algorithm, is also disabled.

The default is Enable.

#### 4.2.6.6.2.9 MIR Threshold Percent (AU only)

Sets the threshold of wireless link utilization above which the MIR/CIR algorithm is activated.

The range is from 0 to 100 (%).

The default is 50%.

#### 4.2.6.6.2.10 Show MIR/CIR Parameters

Displays the current values of the MIR and CIR parameters.

#### 4.2.6.6.3 Traffic Prioritization

Each packet that is received from the Ethernet port is placed in either the High or Low queue, according to the Traffic Prioritization parameters. When the MIR/CIR mechanism decides that a packet must be sent, the High priority queue will be checked first. If the High priority queue is not empty, the first element in the queue is forwarded to the MIR/CIR mechanism. Packets from the Low priority queue will be forwarded only if the High queue is empty.

The prioritization of the packets is done using different classifiers:

- VLAN Priority
- ToS Priority: IP Precedence or DSCP
- UDP and/or TCP ports

Each one of these classifiers can be activated/deactivated. If more than one classifier is activated, the priority of each packet will be determined by the highest priority given to it by the active classifiers.

The Traffic Prioritization menu enables activating/deactivating each of these classifiers, and configuring the applicable parameters for each classifier.

The Low Priority Traffic Minimum Percent parameter can be used to prevent starvation of low priority traffic by ensuring that a certain number of low priority packets is transmitted even at the expense of high priority traffic.

In addition, the Wireless Link Prioritization, which is a licensable feature, enables to configure parameters that affect the prioritization of traffic in the wireless link for packets with high/low priority from different units.

#### 4.2.6.6.3.1 VLAN Priority Threshold

The VLAN Priority Threshold is applicable for Trunk and Hybrid Links only. It enables defining the value of the VLAN Priority Threshold. If the VLAN Priority field in a tagged frame is higher than the value of the VLAN Priority Threshold parameter, the packet will be routed to the High queue. If the VLAN Priority field is lower than or equal to this value, the packet will be transferred to the Low queue (unless it is assigned a High priority by another classifier).

Valid values range from 0 to 7.

The default value is 7, which means that all packets get a low priority (equivalent to disabling the VLAN-based classifier).

#### 4.2.6.6.3.2 ToS Prioritization

The ToS Prioritization parameters enable defining prioritization in accordance with either the 3 IP Precedence bits in the IP header in accordance with RFC 791, or the 6 DSCP (Differentiated Services Code Point) bits in accordance with RFC 2474. The ToS Prioritization menu includes the following parameters:

##### 4.2.6.6.3.2.1 ToS Prioritization Option

The ToS Prioritization Option defines whether ToS-based prioritization is enabled or disabled. The following options are available:

- Disable
- Enable IP Precedence (RFC791) Prioritization
- Enable DSCP (RFC2474) Prioritization

The default is Disable.

#### 4.2.6.6.3.2.2 IP Precedence Threshold

The IP Precedence Threshold parameter is applicable when the ToS Prioritization Option is set to Enable IP Precedence (RFC791) Prioritization. If the value of the 3 IP Precedence bits in the IP header is higher than this threshold, the packet is routed to the High queue. If the value is lower than or equal to this threshold, the packet will be transferred to the Low queue (unless it is assigned a High priority by another classifier).

Valid values range from 0 to 7.

The default value is 4.

#### 4.2.6.6.3.2.3 DSCP Threshold

The DSCP Threshold parameter is applicable when the ToS Prioritization Option is set to Enable DSCP (RFC2474) Prioritization. If the value of the 6 DSCP bits in the IP header is higher than this threshold, the packet is routed to the High queue. If the value is lower than or equal to this threshold, the packet will be routed to the Low queue (unless it is assigned a High priority by another classifier).

Valid values range from 0 to 63.

The default value is 32.

#### 4.2.6.6.3.3 UDP/TCP Port Ranges Traffic Prioritization

The UDP/TCP Port Ranges Traffic Prioritization parameters enable defining prioritization in accordance with the UDP and/or TCP destination port ranges. The UDP/TCP Port Ranges Traffic Prioritization menu includes the following parameters:

##### 4.2.6.6.3.3.1 UDP/TCP Port Ranges Prioritization Option

The UDP/TCP Port Ranges Prioritization Option defines whether port ranges based prioritization is enabled or disabled. The following options are available:

- Disable
- Enable Only for UDP
- Enable Only for TCP
- Enable for both UDP and TCP

The default is Disable.

#### 4.2.6.6.3.3.2 UDP Port Ranges

The UDP Port Ranges menu enables defining port ranges to be used as priority classifiers when the UDP/TCP Port Ranges Prioritization Option is set to either Enable Only for UDP or Enable for both UDP and TCP. All packets whose destination is included in the list will be routed to the High queue. All other packets will be routed to the Low queue (unless they were assigned a High priority by another classifier).

The UDP Port Ranges menu includes the following options:

- **UDP RTP/RTCP Prioritization:** Voice over IP is transported using Real Time Protocol (RTP). The Real Time Control Protocol (RTCP) is used to control the RTP. When an application uses RTP/RTCP, it chooses for destination ports consecutive numbers: RTP port is always an even number, and the port with the odd number following it will be assigned to RTCP.

If the administrator selects to prioritize only the RTP packets, then all the packets with an odd numbered destination port will always have Low priority. The packets with an even number for destination port will receive High priority, if the port number is included in the specified ranges.

If the administrator selects to prioritize both RTP and RTCP packets, then all packets whose destination port number is included is in the specified ranges will receive High priority.

The available options are:

- ◇ RTP & RTCP
- ◇ RTP Only

The default is RTP & RTCP

- **Add UDP Port Ranges:** This option enables adding UDP port ranges to the list of priority port numbers. The list can include up to 64 ranges. It is possible to add discrete port numbers and/or ranges. In ranges, a hyphen is used to separate between start and end port numbers. A comma is used to separate between entries.

For example: 8900,9000-9005,9010,9016-9017.

- **Delete UDP Port Ranges:** This option enables deleting UDP port ranges from the list of priority port numbers. It is possible to delete discrete port numbers and/or ranges. In ranges, a hyphen is used to separate between start and end port numbers. A comma is used to separate between entries.

For example: 8900,9000-9005,9010,9016-9017.

- **Delete All UDP Port Ranges:** This option enables deleting all UDP port ranges from the list of priority port numbers.
- **Show UDP Port Ranges:** Select this option to view the current UDP RTP/RTCP Prioritization option and the list of UDP Port Ranges.

#### 4.2.6.6.3.3.3 TCP Port Ranges

The TCP Port Ranges menu enables defining port ranges to be used as priority classifiers when the UDP/TCP Port Ranges Prioritization Option is set to either Enable Only for TCP or Enable for both UDP and TCP. All packets whose destination is included in the list will be routed to the High queue. All other packets will be routed to the Low queue (unless they were assigned a High priority by another classifier).

The TCP Port Ranges menu includes the following options:

- **TCP RTP/RTCP Prioritization:** Voice over IP is transported using Real Time Protocol (RTP). The Real Time Control Protocol (RTCP) is used to control the RTP. When an application uses RTP/RTCP, it chooses for destination ports consecutive numbers: RTP port is always an even number, and the port with the odd number following it will be assigned to RTCP.

If the administrator selects to prioritize only the RTP packets, then all the packets with an odd numbered destination port will always have Low priority. The packets with an even number for destination port will receive High priority, if the port number is included in the specified ranges.

If the administrator selects to prioritize both RTP and RTCP packets, then all packets whose destination port number is included in the specified ranges will receive High priority.

The available options are:

- ◇ RTP & RTCP
- ◇ RTP Only

The default is RTP & RTCP

- **Add TCP Port Ranges:** This option enables adding TCP port ranges to the list of priority port numbers. The list can include up to 64 ranges. It is possible to add discrete port numbers and/or ranges. In ranges, a hyphen is used to

separate between start and end port numbers. A comma is used to separate between entries. For example: 8900,9000-9005,9010,9016-9017.

- **Delete TCP Port Ranges:** This option enables deleting TCP port ranges from the list of priority port numbers. It is possible to delete discrete port numbers and/or ranges. In ranges, a hyphen is used to separate between start and end port numbers. A comma is used to separate between entries.

For example: 8900,9000-9005,9010,9016-9017.

- **Delete All TCP Port Ranges:** This option enables deleting all TCP port ranges from the list of priority port numbers.
- **Show TCP Port Ranges:** Select this option to view the current TCP RTP/RTCP Prioritization option and the list of TCP Port Ranges.

#### 4.2.6.6.3.4 Low Priority Traffic Minimum Percent

This feature ensures that a certain amount of low priority packets, specified by the Low Priority Traffic Minimum Percent (LPTMP) parameter, is transmitted even at the expense of high priority traffic.

The mechanism guarantees a low priority traffic with a rate of  $LPTMP * RT / 100$ , where RT symbolizes the allowed traffic rate. The high priority traffic will thus not be able to exceed  $(100-LPTMP) * RT / 100$ . If the system receives high priority traffic at a rate higher than this figure, some high priority packets will be discarded.

The range is between 0 and 100 (%).

The default value is 0 (%).

#### 4.2.6.6.3.5 Wireless Link Prioritization Parameters (AU)

To better support delay-sensitive and other high-priority traffic, a set of Wireless Link Prioritization parameters enables configuring parameters that affect the processes of gaining access to the wireless media and of transmitting high/low priority packets.

The Wireless Link Prioritization feature is a licensed feature and is available only in units with the suitable Feature License.

The time interval between two consecutive transmissions of frames is called Inter-Frame Spacing (IFS). This is the time during which the unit determines whether the medium is idle using the carrier sense mechanism. The IFS depends on the type of the next frame to be transmitted, as follows:

- SIFS (Short Inter-Frame Spacing) is used for certain frames that should be transmitted immediately, such as ACK and CTS frames. The value of SIFS is 16 microseconds.
- DIFS (Distributed coordination function Inter-Frame Spacing) is typically used for other frame types when the medium is free. If the unit decides that the medium is not free, it will defer transmission by DIFS plus a number of time slots as determined by the Contention Window back-off algorithm after reaching a decision that the medium has become free. DIFS equal SIFS plus AIFS, where AIFS is a configurable number of time slots.

Under regular conditions, AIFS is configured to two time slots. To support prioritization in the wireless link, we can configure a higher AIFS for low priority traffic (AIFS of two time slots will always be used for high priority traffic as well as AU's transmissions of broadcasts/multicasts and beacons). This will give advantage to units that need to transmit high priority traffic (depending also on the configured values for the Contention Window parameters).

Other parameters related to transmission to the wireless media that can be configured separately for high/low priority packets are the Number of HW Retries and Burst Duration.

Typically, a lower value of Number of HW Retries should be configured for traffic such as VoIP, which on the one hand is sensitive to delays and on the other hand is less sensitive to missing packets than data traffic.

The Burst Duration, which defines the maximum duration of a burst, should be set to a lower value for delay sensitive traffic. Typically the Burst Duration of the AU should be set to higher value than that of the SUs, because of the higher number of packets that should be transmitted by the AU.

When the Wireless Link Prioritization feature is enabled, the following parameters are not applicable:

- Arbitration Inter-Frame Spacing (AIFS)
- Number of HW Retries
- Burst Mode Option
- Burst Mode Time Interval

When an SU with a SW version below 4.0 tries to associate with an AU that has the Wireless Link Prioritization feature enable, the AU will generate a trap that will include information about this SU. In this way the system administrator can be alerted that the SU should be upgraded. This is necessary because otherwise

an SU that does not support the Wireless Link Prioritization feature will send all the traffic as high priority.



**CAUTION**

Verify that all SUs served by an AU with the Wireless Link Prioritization Option enabled use a SW version that supports this feature (SW version 4.0 and higher). Otherwise, overall performance and quality of service in the cell may be reduced since all data from an SU with SW version below 4.0 will be sent with high priority.

The Wireless Link Prioritization Parameters menu includes the following:

#### *4.2.6.6.3.5.1 Wireless Link Prioritization Option*

The Wireless Link Prioritization Option enables or disables the Wireless Link Prioritization feature.

The default option is Disable.

#### *4.2.6.6.3.5.2 Low Priority AIFS*

The Low Priority AIFS defines the AIFS number of time slots that will be used by the AU and the SUs served by it for low priority traffic.

The range is from 3 to 50 (time slots).

The default is 3.

#### *4.2.6.6.3.5.3 Number of HW Retries for High Priority Traffic*

The Number of HW Retries for High Priority Traffic defines the maximum number of times that an unacknowledged high priority unicast packet can be retransmitted. This is the value that will be used by the AU and by the SUs served with it.

The range is from 1 to 14 times.

The default is 10 times.

#### *4.2.6.6.3.5.4 Number of HW Retries for Low Priority Traffic*

The Number of HW Retries for Low Priority Traffic defines the maximum number of times that an unacknowledged low priority unicast packet can be retransmitted. This is the value that will be used by the AU and by the SUs served with it.

The range is from 1 to 14 times.

The default is 10 times.

#### *4.2.6.6.3.5.5 AU Burst Duration for High Priority Traffic*

The AU Burst Duration for High Priority Traffic parameter defines the maximum duration of a burst that can be made by the AU for high priority packets.

The measurement unit is 250 microseconds and the range is from 1 to 40 (0.25 to 10 milliseconds) or 0 to disable bursts for high priority packets.

The default is 16 (4 milliseconds).

#### **4.2.6.6.3.5.6 AU Burst Duration for Low Priority Traffic**

The AU Burst Duration for Low Priority Traffic parameter defines the maximum duration of a burst that can be made by the AU for low priority packets.

The measurement unit is 250 microseconds and the range is from 1 to 40 (0.25 to 10 milliseconds) or 0 to disable bursts for low priority packets.

The default is 20 (5 milliseconds).

#### **4.2.6.6.3.5.7 SU Burst Duration for High Priority Traffic**

The SU Burst Duration for High Priority Traffic parameter defines the maximum duration of a burst that can be made by the SUs served by the AU for high priority packets.

The measurement unit is 250 microseconds and the range is from 1 to 40 (0.25 to 10 milliseconds) or 0 to disable bursts for high priority packets.

The default is 8 (2 milliseconds).

#### **4.2.6.6.3.5.8 SU Burst Duration for Low Priority Traffic**

The SU Burst Duration for Low Priority Traffic parameter defines the maximum duration of a burst that can be made by the SUs served by the AU for low priority packets.

The measurement unit is 250 microseconds and the range is from 1 to 40 (0.25 to 10 milliseconds) or 0 to disable bursts for low priority packets.

The default is 20 (5 milliseconds).

### **4.2.6.6.4 DRAP Parameters (AU only)**

DRAP (Dynamic Resources Allocation Protocol) is a protocol that can be used by the AU to communicate with Voice and Networking Gateways connected to SUs served by it, enabling identification of these Gateways. It also enables managing voice calls made by Voice Gateways (VG).

The AU keeps track of all current voice calls and, upon receiving from a VG a request for a new call, compares the current number of calls to the maximum allowed number. If the maximum allowed number has been reached, the AU will not confirm the request.

The DRAP feature is applicable only for gateways that support DRAP.

The following is a description of DRAP-related parameters:

#### 4.2.6.6.4.1 DRAP Support

The DRAP Support option enables or disables the DRAP feature that offers the possibility of identifying the connected Gateways and limiting the maximum number of voice calls made by Voice Gateways in a cell.

The default option is Enable.

#### 4.2.6.6.4.2 UDP Port

The UDP Port parameter defines the UDP port used by the DRAP protocol.

The range is from 8000 to 8200.

The default value is 8171.

#### 4.2.6.6.4.3 Maximum Number of Voice Calls

The Maximum Number of Voice Calls parameter sets the maximum number of active calls in the cell.

The range is between 0 and 255.

The default value is 40.

#### 4.2.6.6.4.4 DRAP TTL

The DRAP TTL parameter sets the time between two consecutive Allocation Requests from the Gateways. The Allocation requests are used to identify the existence of an active Gateway. In Voice Gateways they also include information about the current number of voice calls and requests for new calls.

The range is between 1 and 255 (seconds).

The default value is 10 (seconds).

#### 4.2.6.6.4.5 Number of Active Voice Calls

This option shows the current number of active voice calls in the cell.

#### 4.2.6.6.5 Show Service Parameters

Displays the current values of the Service Parameters.

## 4.2.6.7 Security Parameters

BreezeACCESS VL systems can support encryption of authentication messages and/or data frames using one of the following encryption standards:

- **WEP** Wired Equivalent Privacy algorithm. WEP is defined in the IEEE 802.11 Wireless LAN standard and is based on the RSA's RC4 encryption algorithm.
- **AES OCB** Advanced Encryption Standard. AES is defined by the National Institute of Standards and Technology (NIST) and is based on Rijndael block cipher. AES OCB (Offset Code Book) is a mode that operates by augmenting the normal encryption process by incorporating an offset value.
- **FIPS 197** is certified for compliance with Federal Information Processing Standards. It provides encryption and message integrity in one solution and implements the Advanced Encryption Standard using Rijndael block cipher.



### NOTE

The FIPS 197 encryption algorithm is a licensed feature, and is available only in units with the required license. FIPS 197 can be supported only in Access Units with HW revision C or higher. FIPS 197 feature license is not available for AUS unit.

The following parameters are available through the Security Parameters menu (in certain units some or all of the security options may not be available):

- Authentication Algorithm
- Data Encryption Option
- Security Mode
- Default Key (SU only)
- Default Multicast Key (AU only)
- Key # 1 to Key # 4
- Promiscuous Authentication (AU only)

### 4.2.6.7.1 Authentication Algorithm

The Authentication Algorithm option determines the operation mode of the selected unit. The following two options are available:

- **Open System:** An SU configured to Open System can only associate with an AU also configured to Open System. In this case, the authentication encryption algorithm is not used.
- **Shared Key:** The authentication messages are encrypted. An SU configured to use a Shared Key can only be authenticated by an AU configured to use a Shared Key, provided the applicable Key (which means both the key number and its content) in the AU is identical to the key selected as the Default Key in the SU.

The default is Open System.



#### NOTE

The Shared Key option cannot be selected before at least one Key is defined. In the SU, a Default Key that refers to a valid Key must be selected.

The AU and all the SUs it serves should be configured to the same Authentication Algorithm option. Mixed operation is not supported.

#### 4.2.6.7.2 Data Encryption Option

The Data Encryption Option allows enabling or disabling data encryption. When enabled, all data frames, including frames using management protocols such as Telnet, FTP, TFTP, SNMP, DHCP and ICMP, are encrypted.

The default is Disable.



#### NOTE

- The AU and all the SUs it serves should be configured to the same Data Encryption Option. Mixed operation is not supported.
- A unit with Data Encryption Option enabled can accept non-encrypted data frames.
- The Maximum Number of Associations must be set to a value of 124 or lower to enable Data Encryption. As long as Data Encryption is enabled, the Maximum Number of Associations cannot be set to a value higher than 124. The Maximum Number of Associations Limit (512 when Data Encryption is disabled, 124 when Data Encryption is enabled) is indicated in the Show Air Interface Parameters display.

#### 4.2.6.7.3 Security Mode

The Security Mode option enables selecting the algorithm to be used for encrypting the authentication messages and/or data frames.

The available options are WEP, AES OCB and FIPS 197 (if available).

The default is WEP.

#### 4.2.6.7.4 Default Key (SU only)

The Default Key defines the Key to be used for encrypting/decrypting the authentication messages (Shared Key mode) and/or data frames (Data Encryption enabled). The AU learns the Default Key from the SU provided it is

one of the Keys defined in the AU. The AU may use different keys when authenticating and/or communicating with different SUs.

Available values range from 1 to 4.

The default is KEY # 1.

#### 4.2.6.7.5 Default Multicast Key (AU only)

The Multicast Default Key defines the Key to be used for encrypting multicasts and broadcasts when Data Encryption is enabled.

Available values range from 1 to 4.

The default is KEY # 1.

#### 4.2.6.7.6 Key # 1 to Key # 4

The Key # options enables defining the encryption key to be used for initializing the pseudo-random number generator that forms part of the encryption/decryption process. The Keys must be set before the Shared Key authentication algorithm or Data Encryption can be used. To support proper operation, both the Key # and the content must be identical at both sides of a wireless link.

Each Key is a string of 32 hexadecimal numbers. For security reasons, it is a “write only” parameter, displayed as a string of asterisks (“\*”).

The default for all 4 Keys is 000...0 (a string of 32 zeros), which means no key.

#### 4.2.6.7.7 Promiscuous Authentication (AU only)

The Promiscuous Authentication mode enables new SUs to join an active cell where Shared Key operation and/or Data Encryption are used, even if this SU does not have the correct security parameters. In promiscuous mode, all downlink transmissions (from AU to SUs) are not encrypted, allowing remote configuration of security parameters, regardless of the current settings in the SUs of the parameters related to data encryption. After a new SU joins the cell it should be remotely configured with the proper parameters (or upgraded). When the SU is configured properly, the Promiscuous Mode should be disabled.

The default is Disable.

#### NOTE



Do not leave the AU in the enabled Promiscuous Authentication mode for prolonged periods. Use it only when absolutely necessary, perform the required actions as quickly as possible and disable it. The unit will return automatically to Promiscuous Authentication disabled mode after reset.

## 4.2.6.8 Country Code Parameters

### 4.2.6.8.1 Country Code Select

The Country Code Select option enables changing the Country Code used by the unit. In the current release this option is applicable only to units in the 5.4 and 5.8 GHz bands.

The default Country Code is set in factory according to the destination country.

#### CAUTION



The selected Country Code must comply with applicable local radio regulations.

### 4.2.6.8.2 Re-apply Country Code Values

After loading a new SW version with any changes in the relevant Country Code, the Re-apply Country Code Values option must be activated for the changes to take effect. Following activation of this feature, the unit must be reset to fully apply the changes.

#### NOTE



Following activation of the Re-apply Country Code Values option, all parameters that are affected by the Country Code (frequency parameters, transmit power parameters, DFS operation, modulation level parameters, burst mode parameters) revert to their factory default values and must be re-configured.



A

---

## Appendix A - Software Version Loading Using TFTP



Firmware upgrades to the unit's FLASH memory can be performed by a simple loading procedure using a TFTP application. Before performing an upgrade procedure, be sure you have the correct files and most recent instructions.

Upgrade packages can be obtained from the Technical Support section of Alvarion's web site, <http://www.alvarion.com/>.

**CAUTION**

Shutting down power to the unit before completion of the loading procedure may cause the unit to be inoperable.

**To load software versions:**

- 1 Verify that IP connectivity to the required unit is established.
- 2 Ensure that the IP address of the PC from which the upgrade is to be performed belongs to the same subnet as the unit to be upgraded, unless the unit is behind a router. If the unit is behind a router, verify that the unit is configured with the correct **Default Gateway Address**.
- 3 To view the current IP parameters of the unit, use the Monitor program by connecting the PC to the unit either directly or via Telnet. To access the IP parameters via the Monitor program:
  - a From the *Main Menu* select **1 - Info Screens**.
  - b From the *Info Screen* menu select **2 - Show Basic Configuration**. The current basic configuration is displayed, including the run time values for the IP Address, Subnet Mask and Default Gateway Address parameters.
- 4 To modify any of the IP parameters:
  - a From the *Main Menu*, select **3 - Basic Configuration**.
  - b To configure the IP address, select: **1 - IP Address**.
  - c To configure the subnet mask, select **2 - Subnet Mask**.
  - d To configure the default gateway address, select **3 - Default Gateway Address**.
  - e Reset the unit to apply the new IP parameters.
- 5 To verify the connection, PING the unit's IP address and verify that PING replies are being received.
- 6 Use the TFTP utility, with the following syntax, to perform the upgrade:

```
tftp -i hostaddress put sourcefile [destinationfile]
```

where *-i* is for binary mode and *hostaddress* is the IP address of the unit to be upgraded. *put* causes the PC client to send a file to the *hostaddress*.

- 7 The original *sourcefile* name of SW files is in the structure *uX\_Y\_Z.bz*, where *u* is the unit type (a for AU, s for SU) and *X.Y.Z* is the version number.
- 8 *destinationfile* is the name of the file to be loaded. Use the SNMP write community *<SnmpWriteCommunity>.bz* to define the destination filename. The default SNMP write community is *private*. For example, to load the upgrade file *a5\_0\_13.bz* to an AU whose IP address is *206.25.63.65*: *tftp -i 206.25.63.65 put a5\_0\_13.bz private.bz*
- 9 When the loading is complete, the following message is displayed, indicating completion of the TFTP process:
 

```
Download operation has been completed successfully
```
- 10 The unit decompresses the loaded file and checks the integrity of the new version. The new version replaces the previous shadow version only after verification. If verification tests fail, the loaded version will be rejected. Among other things that are tested, the unit will reject a file if either the file name or the version number matches the current Main versions. The unit will also reject a file designated for a different unit type, e.g. an AU upgrade file with the prefix *a* in the original file name will not be accepted by SUs.
- 11 The FLASH memory can store two software versions. One version is called *Main* and the second version is called *Shadow*. The new version is loaded into the Shadow (backup) FLASH memory. To check that the new firmware was properly downloaded and verified, view the firmware versions stored in the FLASH, as follows:

- a From the Main Menu, select **2 - Unit Control**.
- b From the Unit Control menu, select **5 - Flash Memory Control**.
- c From the *Flash Memory Control* menu, select **S - Show Flash Versions**. The following information is displayed:

```
Flash Versions
=====
Running from           :Main Version
Main Version File Name : 4_5_16.bz
Main Version Number    : 4.5.16
Shadow Version File Name :5_0_13.bz
Shadow Version Number  :5.0.13
```

**NOTE**

After loading a new SW version with any changes in the relevant Country Code, these changes must be applied by activation the Re-apply Country Code Values option in the Unit Control Menu. Note that following activation of the Re-apply Country Code Values option, all parameters that are affected by the Country Code (frequency parameters, transmit power parameters, DFS operation, modulation level parameters, burst mode parameters) revert to their factory default values and must be re-configured.





# B

---

## Appendix B - File Download and Upload Using TFTP



The File Download/Upload feature simplifies the task of remotely configuring a large number of units using TFTP protocol. By downloading the configuration file to a PC it is possible to view all the parameters configured for the unit, as a plain ASCII text file. It is necessary to edit the file using a simple editor and remove certain parameters or change their values prior to uploading the configuration to another unit. The file loading procedure can also be used for uploading a feature license file or an updated country code file to multiple units.

When multiple configurations are being done simultaneously, that is, the file is being uploaded to several units, it is recommended that the file will include only the required parameters.

In the configuration file, the following three fields represent each parameter:

- 1** A symbolic string similar to the name of the parameter in the Monitor program, followed by "=".
- 2** The value of the parameters, which uses the same values as the Monitor program.
- 3** An optional comment. If used, the comment should start with a ";" character.

An unknown parameter or a known parameter with a value that is invalid or out of range will be ignored.

Use the SNMP write community string (the default is "private") to define both the uploaded file (*put*) and the downloaded file (*get*). The file should be transferred in ASCII mode.

Use the extension *cfg* for a configuration file.

Use the extension *cmr* for the Operator Defaults file.

Use the extension *fln* for a Feature License file.

Use the extension *ccf* for a Country Code file.

Feature license and country code files include multiple strings, where each string is applicable only for a certain unit identified by its MAC address. When uploading a feature license or a country code file to multiple units, each unit will accept only the parts that are applicable for itself.

**Examples:**

- 1** To upload the configuration file using a DOS based TFTP Client to an SU whose IP address is 206.25.63.65, enter:  
tftp 206.25.63.65 put Suconf private.cfg
- 2** To download the Operator Defaults file from the same unit, enter:  
tftp 206.25.63.65 get private.cmr Suconf
- 3** To upload the Feature Upgrade file to the same unit, enter:  
tftp 206.25.63.65 put Suconf private.fln
- 4** To upload the Country Code file from to same unit, enter:  
tftp 206.25.63.65 put Suconf private.ccf

**NOTE**

The Configuration File mechanism is common to BreezeACCESS VL and BreezeNET B product lines. The Configuration File includes also parameters that are applicable only to BreezeNET B products. Do not attempt to change the default values of these parameters.



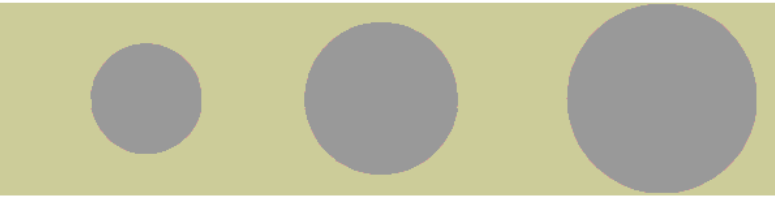

# C

---

## Appendix C - Using the Set Factory Defaults Utility



The Set Factory Defaults utility is intended to enable management access to a unit in cases where such access is not possible due to wrong or unknown configuration of certain parameters. This includes cases such as unknown Management VLAN ID and wrong management access filtering.

The utility accesses the unit by sending a special packet. Access to the unit is based on its MAC address, which must be entered in the **Unit MAC address** field.

The set unit defaults feature is only available via the Ethernet port.



**To set factory defaults:**

- 1 Connect the PC with the Set Factory Defaults utility to the Ethernet port of the unit.

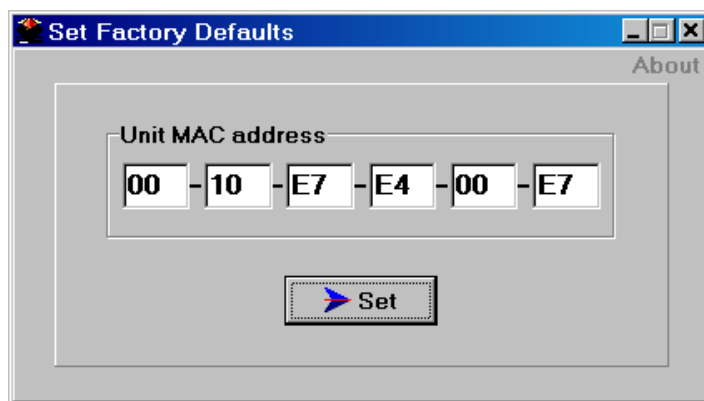

- 2 Enter the unit's MAC address.
- 3 Click on the **Set** button.

This utility performs the same operation as Set Complete Factory Defaults, restoring the default factory configuration of all parameters, except to Passwords, general FTP parameters and AU's Frequency.

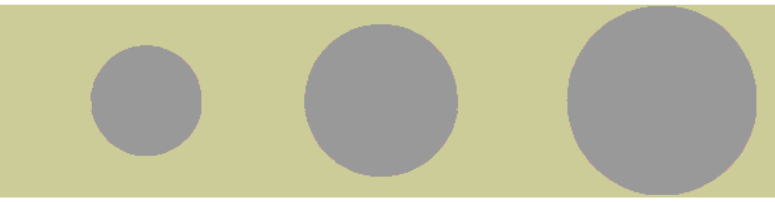

# D

---

## Appendix D - Preparing the Indoor to Outdoor SU Cable



The Indoor-to-Outdoor cable provides pin-to-pin connection on both ends.

Figure 4-2 shows the wire pair connections required for the Indoor-to-Outdoor cable.

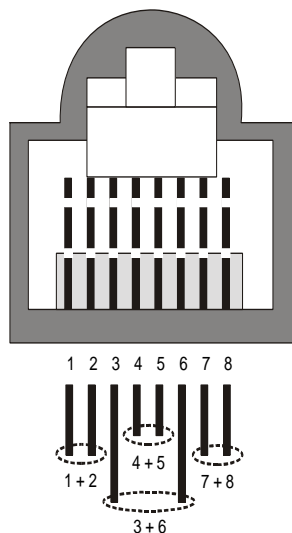

**Figure 4-2: Ethernet Connector Pin Assignments**

The color codes used in cables that are supplied with crimped connectors are as listed in the following table:

Cable Color Codes	
Wire color	Pin
Blue	1
Blue/white	2
Orange	3
Orange/white	6
Brown	4
Brown/white	5
Green	7
Green/white	8

Use a crimp tool for RJ-45 connectors to prepare the wires, insert them into the appropriate pins and use the crimp tool to crimp the connector. Make sure to do the following:

- 1 Remove as small a length as possible of the external jacket. Verify that the external jacket is well inside the service box to ensure good sealing.
- 2 Take back the shield drain wire before inserting the cable into the RJ-45 connector, to ensure a good connection with the connector's shield after crimping.





# E

---

## Appendix E - Parameters Summary

### In This Appendix:

- The tables provide an at a glance summary of the configurable parameters, value ranges, and default values. In addition, each parameter entry also includes an indication as to whether the parameter is updated in run-time or whether the unit must be reset before the modification takes effect (“No” in the Run-Time column indicates that a change to the parameter will take effect only after reset).

## E.1 Parameters Summary

### E.1.1 Unit Control Parameters

Parameter	Unit	Range	Default	Run-Time
Change Unit Name	AU, SU	Up to 32 printable ASCII characters	None	Yes
Change Read Only Password	AU, SU	Up to 8 printable ASCII characters	public	No
Change Installer Password	AU, SU	Up to 8 printable ASCII characters	user	No
Change Administrator Password	AU, SU	Up to 8 printable ASCII characters	private	No
FTP SW Version File Name	AU, SU	Up to 20 printable ASCII characters. An empty string is not allowed.	VxWorks.bz	Yes
Configuration File Name	AU, SU	Up to 20 printable ASCII characters. An empty string is not allowed.	config.cfg	Yes
Operator Defaults File Name	AU, SU	Up to 20 printable ASCII characters. An empty string is not allowed.	operator.cmr	Yes
FTP Source Dir	AU, SU	Up to 80 printable ASCII characters. Use "." to clear.	None (empty)	Yes
FTP Server IP Address	AU, SU	IP address	10.0.0.253	Yes
FTP Gateway IP Address	AU, SU	IP address	0.0.0.0	Yes
FTP User Name	AU, SU	Up to 18 printable ASCII characters	vx	Yes
FTP Password	AU, SU	Up to 18 printable ASCII characters	vx	Yes
FTP Log File Name	AU, SU	Up to 20 printable ASCII characters	logfile.log	Yes
FTP Log File Destination Directory	AU, SU	Up to 80 printable ASCII characters. Use "." to clear.	None (empty)	Yes
Event Log Policy	AU, SU	<ul style="list-style-type: none"> <li>■ Message</li> <li>■ Warning</li> <li>■ Error</li> <li>■ Fatal</li> <li>■ Log None</li> </ul>	Warning	Yes
Log Out Timer	AU, SU	1-999 minutes	5	Yes
Ethernet Port Negotiation Mode	AU, SU	<ul style="list-style-type: none"> <li>■ Force 10 Mbps and Half-Duplex</li> <li>■ Force 10 Mbps and Full-Duplex</li> <li>■ Force 100 Mbps and Half-Duplex</li> <li>■ Force 100 Mbps and Full-Duplex</li> <li>■ Auto Negotiation</li> </ul>	Auto Negotiation	No
Change System Location	AU, SU	Up to 34 printable ASCII characters	None	Yes
Manual Feature Upgrade	AU, SU	License string: 32 to 64 hexadecimal digits	None	No

## E.1.2 IP Parameters

Parameter	Unit	Range	Default	Run-Time
IP Address	AU, SU	IP address	10.0.0.1	No
Subnet Mask	AU, SU	IP address	255.0.0.0	No
Default Gateway Address	AU, SU	IP address	0.0.0.0	No
DHCP Option	AU, SU	<ul style="list-style-type: none"> <li>■ Disable</li> <li>■ DHCP Only</li> <li>■ Automatic</li> </ul>	Disable	No
Access to DHCP	AU, SU	<ul style="list-style-type: none"> <li>■ From Wireless Only</li> <li>■ From Ethernet Only</li> <li>■ From Both Wireless and Ethernet</li> </ul>	AU: From Ethernet Only SU: From Wireless Only	No

## E.1.3 Air Interface Parameters

Parameter	Unit	Range	Default	Run-Time
ESSID	AU, SU	Up to 31 printable ASCII characters	ESSID1	No
Operator ESSID Option	AU	<ul style="list-style-type: none"> <li>■ Disable</li> <li>■ Enable</li> </ul>	Enable	No
Operator ESSID	AU	Up to 31 printable ASCII characters	ESSID1	No
Best AU Support	SU	<ul style="list-style-type: none"> <li>■ Disable</li> <li>■ Enable</li> </ul>	Disable	No
Number of Scanning Attempts	SU	1 – 255	4	No
Preferred AU MAC Address	SU	MAC Address	00-00-00-00-00-00 (no preferred AU)	No
Scanning Mode	SU	Passive, Active	Passive	No
Cell Distance Mode	AU	Automatic, Manual	Automatic	No
Maximum Cell Distance	AU	0-54 (Km) 0 means no compensation	0 (no compensation)	Yes
Fairness Factor	AU	0 – 100 (%)	100 (%)	No
Per SU Distance Learning	AU	<ul style="list-style-type: none"> <li>■ Disable</li> <li>■ Enable</li> </ul>	Disable	Yes
Arbitration Inter-Frame Spacing	AU, SU	1-50 (time slots)	2 time slots	No
Wireless Trap Threshold	AU	1-100 (%)	30 (%)	No
Maximum Number of Associations	AU	AU-BS, AU-SA: 1-512 (1-124 if Data Encryption Option is enabled). AUS-BS, AUS-SA: 1-8	AU-BS, AU-SA: 512 AUS-BS, AUS-SA: 8	Yes
Sub-Band Select*	AU	According to the Country Code	1	Yes
Frequency	AU	According to the Sub-Band	The lowest frequency in the Sub-Band	Yes
User Defined Frequency Subsets	SU	All frequencies in the available Sub Bands	All available frequencies in all available Sub Bands	Yes

Parameter	Unit	Range	Default	Run-Time
DFS Required by Regulations **	AU	<input type="checkbox"/> No <input type="checkbox"/> Yes	Dependent on Country Code.	Yes
Frequency Subset Definition (in AU)**	AU	According to the Sub-Band. A list of frequency indexes or A for all frequencies supported by the Sub-Band	A	Yes
Channel Check Time**	AU	1 – 3600 (seconds)	60 (seconds)	Yes
Channel Avoidance Period**	AU	1 – 60 (minutes)	30 (minutes)	Yes
SU Waiting Option**	AU	<input type="checkbox"/> Disable <input type="checkbox"/> Enable	Enable	Yes
Minimum Pulses to Detect**	AU	1-100	4 for FCC 8 for other (ETSI)	Yes
Clear radar Detected Channels After Reset**	AU	<input type="checkbox"/> Disable <input type="checkbox"/> Enable	Disable	Yes
Channel Reuse Option**	AU	<input type="checkbox"/> Disable <input type="checkbox"/> Enable	Disable	Yes
Radar Activity Assessment Period**	AU	1 – 12 hours	5 hours	Yes
Maximum Number of Detections in Assessment Period**	AU	1 – 10 detections	5 detections	Yes
Country Code Learning by SU	AU	<input type="checkbox"/> Disable <input type="checkbox"/> Enable	Disable	Yes
Transmit Power	AU, SU	-10 dBm to a value that depends on HW revision , Country Code / Antenna Gain and (in SU) the Max Tx Power parameter	The highest allowed value	Yes
Maximum Tx Power	SU	-10 dBm to a value that depends on HW revision and Country Code / Antenna Gain	The highest allowed value	Yes
ATPC Option	AU, SU	<input type="checkbox"/> Disable <input type="checkbox"/> Enable	Enable	Yes
Delta from Minimum SNR Level	AU	4-20 (dB)	<input type="checkbox"/> Units in 0.9, 5.4, 5.8 GHz bands: 5 (dB) <input type="checkbox"/> Units in the 4.9, 5.2 and 5.3 GHz bands: 8 (dB)	Yes
Minimum SNR Level	AU	4-60 (dB)	28 (dB)	Yes
Minimum Interval Between ATPC Messages	AU	1-3600 (seconds)	30 (seconds)	Yes
ATPC Power Level Steps	AU	1-20 (dB)	4	Yes
Tx Control	AU	<input type="checkbox"/> Off <input type="checkbox"/> On <input type="checkbox"/> Ethernet Status Control	On	Yes
Antenna Gain	AU, SU***	Minimum: 0 (dBi) Maximum: 50 or Regulation Max EIRP+10 (the lower of the two values).	According to the antenna supplied with the unit.	No

Parameter	Unit	Range	Default	Run-Time
Spectrum Analysis Channel Scan Period	AU, SU	2 – 30 seconds	5 seconds	Yes (Configured per analysis)
Spectrum Analysis Scan Cycles	AU, SU	1 – 100 cycles	2 cycles	Yes (Configured per analysis)
Automatic Channel Selection	AU	<input type="checkbox"/> Disable <input type="checkbox"/> Enable	Disable	Yes
Lost Beacons Watchdog Threshold	AU	100 – 1000, 0 means Not Used	218	Yes
Noise Immunity State Control	AU, SU	<input type="checkbox"/> Automatic <input type="checkbox"/> Manual	Automatic	Yes
Noise Immunity Level	AU, SU	0 – 4 Use only 0 or 4	0	Yes
Spur Immunity Level	AU, SU	0 – 7	0	Yes
OFDM Weak Signal	AU, SU	0 (not active) or 1 (active)	0	Yes
Pulse Detection Sensitivity	AU, SU	<input type="checkbox"/> Low <input type="checkbox"/> High	Low	Yes
Noise Floor Calculation Mode	AU, SU	<input type="checkbox"/> Fully Automatic <input type="checkbox"/> Forced <input type="checkbox"/> Automatic with Minimum Value	Fully Automatic	Yes
Noise Floor Forced Value	AU, SU	-107 to -55 (dBm)	5 MHz bandwidth: -102 10 MHz bandwidth: -99 20 MHz bandwidth: -96	Yes

\* Not applicable if only one Sub-Band is available for the applicable Country Code

\*\* Applicable only if DFS is supported by the Sub-Band

\*\*\* Configurable only in units without an integral antenna.

## E.1.4 Network Management Parameters

Parameter	Unit	Range	Default	Run-Time
Access to Network Management	AU, SU	<ul style="list-style-type: none"> <li>■ From Wireless Link Only</li> <li>■ From Ethernet Only</li> <li>■ From Both Ethernet and Wireless Link</li> </ul>	From Both Ethernet and Wireless Link	No
Network Management Filtering	AU, SU	<ul style="list-style-type: none"> <li>■ Disable</li> <li>■ Activate Management IP Filter On Ethernet Port</li> <li>■ Activate Management IP Filter On Wireless Port</li> <li>■ Activate Management IP Filter On Both Ethernet and Wireless Ports</li> </ul>	Disable	No
Set Network Management IP Address	AU, SU	IP address	0.0.0.0 (all 10 entries)	No
Set/Change Network Management IP Address Ranges	AU, SU	<start address> to <end address> or, <base address> mask <mask>	0.0.0.0 TO 0.0.0.0 (all 10 entries)	No
Send SNMP Traps	AU	<ul style="list-style-type: none"> <li>■ Disable</li> <li>■ Enable</li> </ul>	Disable	Yes
SNMP Traps IP Destination	AU	IP address	0.0.0.0 (all 10 entries)	No
SNMP Traps Community	AU	Up to 14 printable ASCII characters	public (all 10 entries)	No
Wi2 IP Address	SU	IP address	0.0.0.0 (none)	Yes

## E.1.5 Bridge Parameters

Parameter	Unit	Range	Default	Run-Time
VLAN ID-Data	SU	1 – 4094	1	No
VLAN ID – Management	AU, SU	1 – 4094, 65535	65535 (no VLAN)	No
VLAN Link Type	AU, SU	<ul style="list-style-type: none"> <li>■ Hybrid Link</li> <li>■ Trunk Link</li> <li>■ Access Link (only in SU)</li> <li>■ Service Provider Link</li> </ul>	Hybrid Link	No
VLAN Forwarding Support	AU, SU	Disable, Enable	Disable	No
VLAN Forwarding ID	AU, SU	1 – 4094 (up to 20 entries)	Empty list	No
VLAN Relaying Support	AU	Disable, Enable	Disable	No
VLAN Relaying ID	AU	1 – 4094 (up to 20 entries)	Empty list	No
VLAN Priority – Data	SU	0 – 7	0	No
VLAN Priority – Management	AU, SU	0 – 7	0	No
VLAN QinQ Protocol Ethertype	AU, SU	8100 – 9000, 9100, 9200 (hex)	8100 (hex)	No
Service Provider VLAN ID	SU	1 – 4094	1	No

Parameter	Unit	Range	Default	Run-Time
Ethernet Broadcast Filtering Options	SU	<ul style="list-style-type: none"> <li>■ Disable,</li> <li>■ On Ethernet Port Only</li> <li>■ On Wireless Port Only</li> <li>■ On Both Wireless and Ethernet Ports</li> </ul>	Disable	Yes
DHCP Broadcast Override Filter	SU	<ul style="list-style-type: none"> <li>■ Disable</li> <li>■ Enable</li> </ul>	Disable	Yes
PPPoE Broadcast Override Filter	SU	<ul style="list-style-type: none"> <li>■ Disable</li> <li>■ Enable</li> </ul>	Disable	Yes
ARP Broadcast Override Filter	SU	<ul style="list-style-type: none"> <li>■ Disable</li> <li>■ Enable</li> </ul>	Enable	Yes
Ethernet Broadcast/Multicast Limiter Option	AU, SU	<ul style="list-style-type: none"> <li>■ Disable</li> <li>■ Limit only Broadcast Packets</li> <li>■ Limit Multicast Packets that are not Broadcasts</li> <li>■ Limit All Multicast Packets (including broadcast)</li> </ul>	Disable	Yes
Ethernet Broadcast/Multicast Limiter Threshold	AU, SU	0 – 204800 (packets/second)	50	Yes
Ethernet Broadcast/Multicast Limiter Send Trap Interval	AU, SU	1 – 60 (minutes)	5 (minutes)	Yes
Bridge Aging Time	AU, SU	20 – 2000 seconds	300	No
Broadcast/Multicast Relaying	AU	<ul style="list-style-type: none"> <li>■ Disable</li> <li>■ Broadcast/Multicast Enable</li> <li>■ Broadcast Enable</li> <li>■ Multicast Enable</li> </ul>	Broadcast/Multicast Enable	No
Unicast Relaying	AU	<ul style="list-style-type: none"> <li>■ Disable</li> <li>■ Enable</li> </ul>	Enable	No
MAC Address List	AU	Up to 100 MAC addresses	None (empty)	Yes
MAC Address List Action	AU	<ul style="list-style-type: none"> <li>■ Deny</li> <li>■ Allow</li> </ul>	Deny	Yes
Station Allowed Option		<ul style="list-style-type: none"> <li>■ Disable</li> <li>■ Enable</li> </ul>	Enable	Yes
Roaming Option	SU	<ul style="list-style-type: none"> <li>■ Disable</li> <li>■ Enable</li> </ul>	Disable	No
Ethernet Port Control	SU	<ul style="list-style-type: none"> <li>■ Disable</li> <li>■ Enable</li> </ul>	Enable	Yes

## E.1.6 Performance Parameters

Parameter	Unit	Range	Default	Run-Time
RTS Threshold	AU, SU	HW Revision C or higher: 20-4092 (bytes) HW Revision A, B: 20-2200.	<ul style="list-style-type: none"> <li>■ AU HW Revision A, B: 2200</li> <li>■ AU HW Revision C or higher (except in the 900 MHz band): 4092</li> <li>■ AU in the 900 MHz band: 60</li> <li>■ SU: 60</li> </ul>	Yes
Minimum Contention Window	AU, SU	0, 7, 15, 31, 63, 127, 255, 511, 1023	15	No
Maximum Contention Window	AU, SU	7, 15, 31, 63, 127, 255, 511, 1023	1023	No
Maximum Modulation Level	AU, SU	According to the Min/Max Modulation Level defined for the Sub-Band	<ul style="list-style-type: none"> <li>■ 5 for SUs with HW revision F</li> <li>■ The highest available value for the rest of the units</li> </ul>	Yes
Multicast Modulation Level	AU	According to the Min/Max Modulation Level defined for the Sub-Band	The lowest available value	Yes
Number of HW Retries	AU, SU	1 - 14	10	Yes
Average SNR Memory Factor	AU, SU	-1 to 32	5	Yes
Burst Mode Option*	AU, SU	<ul style="list-style-type: none"> <li>■ Disable</li> <li>■ Enable</li> </ul>	Enable	No
Burst Mode Time Interval*	AU, SU	1 to the value defined in the Sub-Band for Maximum Burst Duration (milliseconds)	5 milliseconds or the value of Maximum Burst Duration defined for the Sub-Band (the lower of the two values).	Yes
Adaptive Modulation Option	AU, SU	<ul style="list-style-type: none"> <li>■ Disable</li> <li>■ Enable</li> </ul>	Enable	No
Minimum Interval Between Adaptive Modulation Messages	AU, SU	1-3600 (seconds)	4 (seconds)	Yes
Adaptive Modulation Decision Threshold	AU, SU	<ul style="list-style-type: none"> <li>■ Normal</li> <li>■ High</li> </ul>	Normal	No
Concatenation Option	AU, SU	<ul style="list-style-type: none"> <li>■ Disable</li> <li>■ Enable</li> </ul>	Enable	No
Maximum Concatenated Frame Size	AU, SU	<ul style="list-style-type: none"> <li>■ 256 to 2200 bytes for units with HW revision A or B</li> <li>■ 256 to 4032 bytes for units with HW revision C or higher</li> </ul>	<ul style="list-style-type: none"> <li>■ 2200 for units with rev A or B</li> <li>■ 4032 for units with rev C or higher</li> </ul>	Yes

\* Applicable only if Burst Mode is supported by the Sub-Band.

## E.1.7 Service Parameters

Parameter	Unit	Range	Default	Run-Time
User Filtering Option	SU	<ul style="list-style-type: none"> <li>■ Disable</li> <li>■ IP Protocol Only</li> <li>■ User Defined Addresses Only</li> <li>■ PPPoE Protocol Only</li> </ul>	Disable	Yes
Set/Change Filter IP Address Ranges	SU	<start address> to <end address> or, <base address> mask <mask>	0.0.0.0 TO 0.0.0.0 (all 8 entries)	No
DHCP Unicast Override Filter	SU	<ul style="list-style-type: none"> <li>■ Disable DHCP Unicast</li> <li>■ Enable DHCP Unicast</li> </ul>	Disable DHCP Unicast	Yes
MIR: Downlink	SU	SU-3: 128-3072 (Kbps) SU-6: 128-6016 (Kbps) SU-8: 128-13440 (Kbps) SU-54: 128-53888 (Kbps) SU-I: 128-6016 (Kbps)	SU-3: 3072 SU-6: 6016 SU-8: 13440 SU-54: 53888 SU-I: 6016	Yes
MIR: Uplink	SU	SU-3: 128-2048 (Kbps) SU-6: 128-4096 (Kbps) SU-8: 128-13440 (Kbps) SU-54: 128-53888 (Kbps) SU-I: 128-4096 (Kbps)	SU-3: 2048 SU-6: 4096 SU-8: 13440 SU-54: 53888 SU-I: 4096	Yes
CIR: Downlink	SU	SU-3: 0-2048 (Kbps) SU-6: 0-4096 (Kbps) SU-8: 0-11264 (Kbps) SU-54: 0-45056 (Kbps) SU-I: 0-6016 (Kbps)	0 (Kbps)	Yes
CIR: Uplink	SU	SU-3: 0-2048 (Kbps) SU-6: 0-4096 (Kbps) SU-8: 0-11264 (Kbps) SU-54: 0-45056 (Kbps) SU-I: 0-4096 (Kbps)	0 (Kbps)	Yes
Maximum Delay	SU	300 – 10,000 (ms)	5,000 (ms)	Yes
Maximum Burst Duration	AU, SU	0 – 2,000 (ms)	5 (ms)	No
Graceful Degradation Limit	AU	0 – 70 (%)	70 (%)	No
MIR Only Option	AU	<ul style="list-style-type: none"> <li>■ Disable</li> <li>■ Enable</li> </ul>	Enable	No
MIR Threshold Percent	AU	0 – 100 (%)	50 (%)	Yes
VLAN Priority Threshold	AU, SU	0 – 7	7	No
ToS Prioritization Option	AU, SU	<ul style="list-style-type: none"> <li>■ Disable</li> <li>■ Enable IP Precedence (RFC791) Prioritization</li> <li>■ Enable DSCP (RFC2474) Prioritization</li> </ul>	Disable	No
IP Precedence Threshold	AU, SU	0 – 7	4	No
DSCP Threshold	AU, SU	0 – 63	32	No
UDP/TCP Port Ranges Prioritization Option	AU, SU	<ul style="list-style-type: none"> <li>■ Disable</li> <li>■ Enable Only for UDP</li> <li>■ Enable Only for TCP</li> <li>■ Enable for both UDP and TCP</li> </ul>	Disable	No
UDP RTP/RTCP Prioritization	AU, SU	<ul style="list-style-type: none"> <li>■ RTP &amp; RTCP</li> <li>■ RTP Only</li> </ul>	RTP & RTCP	No

Parameter	Unit	Range	Default	Run-Time
TCP RTP/RTCP Prioritization	AU, SU	<input type="checkbox"/> RTP & RTCP <input type="checkbox"/> RTP Only	RTP & RTCP	No
Low Priority Traffic Minimum Percent	AU, SU	0 – 100 (%)	0 (%)	Yes
Wireless Link Prioritization Option*	AU	<input type="checkbox"/> Disable <input type="checkbox"/> Enable	Disable	Yes
Low Priority AIFS*	AU	3-50	3	Yes
Number of HW Retries for High Priority Traffic*	AU	1-14	10	Yes
Number of HW Retries for Low Priority Traffic*	AU	1-14	10	Yes
AU Burst Duration for High Priority Traffic*	AU	0-40 (in 0.25 milliseconds units)	16 (4 milliseconds)	Yes
AU Burst Duration for Low Priority Traffic*	AU	0-40 (in 0.25 milliseconds units)	20 (5 milliseconds)	Yes
SU Burst Duration for High Priority Traffic*	AU	0-40 (in 0.25 milliseconds units)	8 (2 milliseconds)	Yes
SU Burst Duration for Low Priority Traffic*	AU	0-40 (in 0.25 milliseconds units)	20 (5 milliseconds)	Yes
DRAP Support	AU	<input type="checkbox"/> Disable <input type="checkbox"/> Enable	Enable	No
UDP Port	AU	8000–8200	8171	No
Maximum Number Of Voice Calls	AU	1–255	40	No
DRAP TTL	AU	1–255 (seconds)	10 (seconds)	No

\* Wireless Link Prioritization parameters are applicable only for units with a license for this feature

## E.1.8 Security Parameters

Parameter	Unit	Range	Default	Run-Time
Authentication Algorithm*	AU, SU	<input type="checkbox"/> Open system <input type="checkbox"/> Shared Key	Open system	No
Data Encryption Option*	AU, SU	<input type="checkbox"/> Disable <input type="checkbox"/> Enable	Disable	No
Security Mode*	AU, SU	<input type="checkbox"/> WEP <input type="checkbox"/> AES OCB <input type="checkbox"/> FIPS-197**	WEP	No
Default Key	SU	1-4	1	No
Default Multicast Key	AU	1-4	1	No
Key # 1 to Key # 4	AU, SU	32 hexadecimal digits	0...0 (all 0=no key)	No
Promiscuous Authentication	AU	<input type="checkbox"/> Disable <input type="checkbox"/> Enable	Disable	Yes (Disable after reset)

\* Applicable only if supported by the Sub-Band.

\*\* The FIPS-197 option is available only in units with HW revision C or higher that have the applicable license.







F

---

## Appendix F - Troubleshooting



## F.1 Ethernet Port Connection Problems

Problem and Indication	Possible Cause	Corrective Action
The Ethernet Integrity Indicator (the yellow LED embedded in the Ethernet connector) is off, and/or the Ethernet Activity Indicator (the green embedded LED) does not blink when there should be traffic on the Ethernet port.	Wrong type of Ethernet cable	If connected directly to PC-use a crossed cable. Otherwise-use a straight cable
	Faulty Ethernet cable	Replace cable
The unit does not respond to ping.	Wrong IP configuration	Make sure that the PC is on the same subnet as the unit*.
	Wrong Ethernet port operation mode	Make sure that the speed and duplex settings in the PC match the configuration in the unit (the default is Auto Negotiation)
	Wrong Management VLAN, User Filtering, Access to Management..	Make sure all relevant parameters are configured properly

\* If the IP parameters of the unit are unknown, use the Set Factory Defaults utility to restore the default factory configuration of all parameters (except to Passwords, general FTP parameters and AU's Frequency). The IP address of the unit after setting to factory defaults is 10.0.0.1.

## F.2 SU Association Problems

Problem and Indication	Possible Cause	Corrective Action
SU does not associate with AU	Wrong configuration	Check proper configuration of basic parameters: <ul style="list-style-type: none"> <li>■ ESSID</li> <li>■ Sub-band and frequencies subset</li> <li>■ Best AU parameters</li> <li>■ ATPC Option</li> <li>■ Transmit Power</li> <li>■ Maximum Transmit Power</li> <li>■ Antenna Gain</li> <li>■ Security parameters: Authentication Algorithm, and Default Key. If necessary-use Promiscuous Mode in AU.</li> </ul>
	Access is denied by AU	Verify that the SU is not included in MAC Address Deny List of the AU.
	Link quality is too low	<ul style="list-style-type: none"> <li>■ Verify that unit is in coverage area of AU according to radio planning.</li> <li>■ Verify that antenna is directed toward the AU</li> <li>■ Try to improve location/height of antenna.</li> </ul>

## F.3 Low Throughput Problems

Problem and Indication	Possible Cause	Corrective Action
Low throughput is suspected  (Check the dominant Modulation Level in Per rate Counters and see expected throughput in the "Expected Throughput" table below)	Ethernet link problems	<ul style="list-style-type: none"> <li>■ Verify proper settings of Ethernet operation mode (actual Ethernet speed of 100 Mbps).</li> <li>■ Check Ethernet counters</li> </ul>
	Wrong configuration of Maximum Modulation level	Verify that Maximum Modulation level is not set to a value that is not too low according to the "Recommended Maximum Modulation Level" table below.
Low throughput of multicast/broadcast traffic	Non-optimal configuration of Multicast Modulation level	A value that is too low (see the "Recommended Maximum Modulation Level" table below) may degrade throughput of broadcast and multicast traffic.
High retransmissions rate	Interference problems (retransmissions rate in excess of 15%)	Check for interference using the Spectrum Analysis Mode. If necessary, change the operating frequency of the AU.

<b>Expected Throughput in Mbps, TCP Traffic @ 20 MHz Bandwidth, Burst Mode Enabled, Concatenation Enabled</b>									
Unit	TCP Traffic	Modulation Level							
		1	2	3	4	5	6	7	8
<b>SU-3</b>	Uplink	1.9	1.9	1.9	1.9	1.9	1.9	1.9	1.9
	Downlink	2.9	2.9	2.9	2.9	2.9	2.9	2.9	2.9
	Aggregate (Bi-directional)	3.3	3.3	3.3	3.3	3.3	3.3	3.3	3.3
<b>SU-6</b>	Uplink	3.8	3.8	3.8	3.8	3.8	3.8	3.8	3.8
	Downlink	4.8	5.6	5.6	5.6	5.6	5.6	5.6	5.6
	Aggregate (Bi-directional)	5	6.7	7	7.1	7.1	7.2	7.2	7.2
<b>SU-54</b>	Uplink	4.7	6.7	8.9	12.4	15.8	21	25.1	26.4
	Downlink	4.8	7.1	9.4	13.7	17.7	24.7	28.9	30.1
	Aggregate (Bi-directional)	4.8	7	9.3	13.1	16.9	22.8	29.4	32

\* The throughput results are for net TCP traffic (excluding protocols overheads)

Recommended Maximum Modulation Level*	
SNR	Maximum Modulation Level
SNR > 23 dB	8
21 dB < SNR < 23 dB	7
16 dB < SNR < 21 dB	6
13 dB < SNR < 16 dB	5
10 dB < SNR < 13 dB	4
8 dB < SNR < 10 dB	3
7 dB < SNR < 8 dB	2
6 dB < SNR < 7 dB	1

\* The maximum supported value depends on the unit's HW revision and on the Max Modulation Level according to the Sub-Band.