



Din Rail AC Power Surge Protector

DS250VG



DS250VG is a heavy duty AC Surge Protection Device (SPD) for high risk, low tolerance electrical service entrance applications. The DS250VG provides protection against the direct and indirect effects of lightning and is particularly useful in a high lightning area where the risk of heavy surge current or even direct strike is high, i.e. buildings equipped with lightning rods.

The DS250VG is a one pole module that can be configured for both common and differential mode protection in any single or three phase application to 277/480Vac.

The DS250VG incorporates a patented MOV-GDT hybrid protection circuit that allows for very high surge current handling 25kA 10/350us, no leakage current to ground, no follow on current and the industry's lowest residual clamp voltages. The module is din rail mountable with dual terminal connectors for in-line wiring up to 250A. The DS250VG include integral thermal disconnection compliant to UL-60691, a visual fault indicator as well as remote signal contacts.

Dimensions and Diagram (in mm)

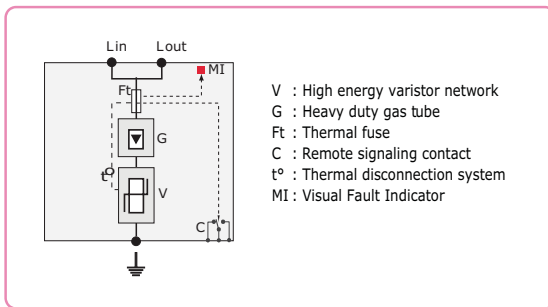
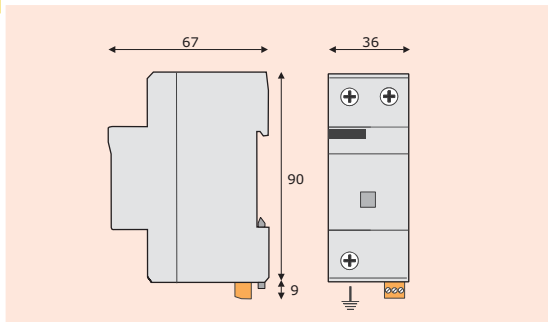

Characteristics

CITEL Part Number	DS250VG-300	DS250VG-120
AC Network	230/400V 277/480V	120/208V 120/240V
Connection Mode	1 Pole, L-N or L-G	1 Pole, L-N or L-G
UL Max. Operating Voltage (MCOV)	330Vac	150Vac
TOV Withstand (UT)	400Vac	150Vac
Leakage Current at MCOV (Ic)	none	none
Follow Current (If)	none	none
IEC/UL Nominal Discharge Current (In) 15 impulses 8/20 µs	30kA/20kA	30kA/20kA
Max. Discharge Current (Imax) 1 impulse 8/20 µs	70kA	70kA
Max. Lightning Current (Iimp) 1 impulse 10/350 µs	25kA	25kA
UL Voltage Protection Rating (VPR)	1200V	600V
Protection Level at In (Up)	1500V	1000V
UL Short-Circuit Current Rating (SCCR)	100kAIC	100kAIC
AC System	IT, TT, TN, Single, Split Phase, Delta, Wye	
Thermal Disconnector	UL 60691	
Overcurrent Protection	Time Delay - 250A Max.	
Dimensions	90 x 36 x 67 (in mm)	
Connection	by screw terminals, #4 AWG Max.	
Visual Fault Indicator	1 Mechanical Indicator	
Remote Signal Indicator	250Vac Max, 2A Form C contacts	
Mounting	Din Rail, 35mm Symmetrical	
Operating Temp	-50°C to +85°C	
Operating Altitude	13,000 ft (4,000m)	
Relative Humidity	5 to 95% non-condensing, up to 100% external	
Enclosure Material	Thermoplastic UL94-5A	
Environmental Rating	IP20	
Weight	7.3 oz	
Standards Compliance		
IEC 61643-1 - INTERNATIONAL	Class I, Class II	
EN 61643-11 - EUROPE	Class I, Class II	
NF EN 61643-11 - FRANCE	Class I, Class II	
UL1449 3rd Edition - USA	Type 4, Type 2 Location	
UL1449 3rd Edition - CANADA	Type 4, Type 2 Location	
CSA C22.2 No. 8-M1986	Class 9091 32, Class 9091 92	
RoHS	Directive 2002/95/EC	

Association with DS100EG protectors

For example : DS254VG-300/G

