

**19-inch**  
**FNSW-4800**

# **48-Port 10/100Mbps Fast Ethernet Switch**



**User's Manual**

# **48-Port 10/100Mbps Fast Ethernet Switch**

**FNSW-4800v2**

**User's Manual**

## **Trademarks**

Copyright © PLANET Technology Corp. 2008.

Contents subject to revision without prior notice.

PLANET is a registered trademark of PLANET Technology Corp. All other trademarks belong to their respective owners.

## **Disclaimer**

PLANET Technology does not warrant that the hardware will work properly in all environments and applications, and makes no warranty and representation, either implied or expressed, with respect to the quality, performance, merchantability, or fitness for a particular purpose.

PLANET has made every effort to ensure that this User's Manual is accurate; PLANET disclaims liability for any inaccuracies or omissions that may have occurred.

Information in this User's Manual is subject to change without notice and does not represent a commitment on the part of PLANET. PLANET assumes no responsibility for any inaccuracies that may be contained in this User's Manual. PLANET makes no commitment to update or keep current the information in this User's Manual, and reserves the right to make improvements to this User's Manual and/or to the products described in this User's Manual, at any time without notice.

If you find information in this manual that is incorrect, misleading, or incomplete, we would appreciate your comments and suggestions.

## **FCC Warning**

This equipment has been tested and found to comply with the limits for a Class A digital device, pursuant to Part 15 of the FCC Rules. These limits are designed to provide reasonable protection against harmful interference when the equipment is operated in a commercial environment. This equipment generates, uses, and can radiate radio frequency energy and, if not installed and used in accordance with the Instruction manual, may cause harmful interference to radio

communications. Operation of this equipment in a residential area is likely to cause harmful interference in which case the user will be required to correct the interference at his own expense.

## **CE Mark Warning**

This is a Class A product. In a domestic environment, this product may cause radio interference, in which case the user may be required to take adequate measures.

## **WEEE Warning**



To avoid the potential effects on the environment and human health as a result of the presence of hazardous substances in electrical and electronic equipment, end users of electrical and electronic equipment should understand the meaning of the crossed-out wheeled bin symbol. Do not dispose of WEEE as unsorted municipal waste and have to collect such WEEE separately.

## **Revision**

PLANET 48-Port 10/100Mbps Fast Ethernet Switch User's Manual

For Model: FNSW-4800v2

Revision: 1.1 (January 2008)

Part No: EM\_FNSW48v2 (2011-A50110-001)

# Table Of Contents

1. Introduction .....	5
1.1 Checklist .....	5
1.2 About the Switch .....	5
1.3 Features .....	6
1.4 Specification .....	7
2. Hardware Description .....	8
2.1 Front Panel .....	8
2.2 Rear Panel .....	9
2.3 Hardware Installation .....	9
3. Switch Operation .....	12
3.1 Address Table .....	12
3.2 Learning .....	12
3.3 Forwarding & Filtering .....	12
3.4 Store-and-Forward .....	12
3.5 Auto-Negotiation .....	13
4. Troubleshooting .....	14
Appendix A Networking Connection .....	15
A.1 Switch's RJ-45 Pin Assignments .....	15
A.2 RJ-45 cable pin assignment .....	15

---

# 1. Introduction

## 1.1 Checklist

Check the contents of your package for following parts:

- FNSW-4800 x 1
- User's manual x 1
- Power cord x 1
- Rubber feet x 4
- Two rack-mounting brackets with attachment screws x 1

If any of these pieces are missing or damaged, please contact your dealer immediately, if possible, retain the carton including the original packing material, and use them against to repack the product in case there is a need to return it to us for repair.

In the following section, the term "Switch" means the FNSW-4800; term of "switch" can be any third part switches

## 1.2 About the Switch

The PLANET FNSW-4800 is a 48-Port 10/100Mbps Fast Ethernet Switch which boasts high performance switch architecture that is capable of providing non-blocking switch fabric and wire-speed throughput as high as 8.8Gbps. With its Auto-negotiation capability, all the RJ-45 ports can be configured to speeds of 10/20Mbps or 100/200Mbps automatically. The FNSW-4800 supports MDI/MDI-X convertible on 48-10/100Mbps ports, the dual speed ports use standard twisted-pair cabling and are ideal for SOHO or segmenting networks.

The FNSW-4800 also supports store-and-forward forwarding scheme to ensure low latency and high data integrity, eliminates unnecessary traffic and relieves congestion on critical network paths. With intelligent address recognition algorithm, the FNSW-4800 could recognize up to 8K different MAC address, enables filtering and forwarding at full wire speed.

The front panel of FNSW-4800 provides LEDs for easy recognition of

---

the switch operation status and troubleshooting. These LED indicators display the power status for the system, LNK/ACT for each 10/100Mbps port.

### 1.3 Features

- Comply with IEEE 802.3 and IEEE 802.3u standards for 10/100Base-TX
- 48-Port 10/100Mbps Fast Ethernet Switch
- Each Switching ports support auto-negotiation-10/20, 100/200Mbps supported
- Auto-MDI/MDI-X detection on each RJ-45 port
- Prevents packet loss with back pressure (Half-duplex) and 802.3x PAUSE frame flow control (Full-duplex)
- High performance Store and Forward architecture, broadcast storm control, runt/CRC filtering eliminates erroneous packets to optimize network bandwidth
- 8K MAC address table, automatic source address learning and ageing
- 2.5Mbit embedded memory for packet buffers
- Support up to 1522 bytes packet and 802.1Q VLAN transparent
- 19-inch rack mount size
- Internal full-range power supply suitable for worldwide use
- EMI standards comply with FCC, CE class A

## 1.4 Specification

Product	FNSW-4800v2 48-Port 10/100Mbps Fast Ethernet Switch
Hardware Specification	
Ports	48 10/ 100Base-TX RJ-45 Auto-MDI/MDI-X ports
Switch Processing Scheme	Store-and-Forward
Throughput (packet per second)	6.6Mpps
Switch fabric	8.8Gbps
Address Table	8K entries
Share data Buffer	2.5Mbit
Flow Control	Back pressure for half duplex, IEEE 802.3x Pause Frame for full duplex
Dimensions (W x D x H)	440 x 260 x 44 mm, 1U height
Weight	3.18kg
Power Requirement	100~240V AC, 50-60 Hz, 0.6A
Power Consumption / Dissipation	18 Watts / 61 BTU
Temperature	Operating: 0~50 degree C, Storage -40~70 degree C
Humidity Operating:	10% to 90%, Storage: 5% to 95% (Non-condensing)
Standards Conformance	
Regulation Compliance	FCC Part 15 Class A, CE
Standards Compliance	IEEE 802.3 (Ethernet) IEEE 802.3u (Fast Ethernet) IEEE 802.3x (Flow control)

## 2. Hardware Description

This product provides two different running speeds – 10Mbps, 100Mbps in the same Switch and automatically distinguishes the speed of incoming connection.

This section describes the hardware features of FNSW-4800. For easier management and control of the Switch, familiarize yourself with its display indicators, and ports. Front panel illustrations in this chapter display the unit LED indicators. Before connecting any network device to the FNSW-4800, read this chapter carefully.

### 2.1 Front Panel

The Front Panel of the FNSW-4800 Fast Ethernet Switch consists of 48x Auto-Sensing 10/100Mbps Ethernet RJ-45 Ports, the LED Indicators are also located on the front panel of the FNSW-4800.



Figure 2-1 FNSW-4800 Switch front panel

#### 2.1.1 LED indicators

##### System

LED	Color	Function
PWR	Green	Lights to indicate that the Switch has power.

##### Per 10/100Mbps port

LED	Color	Function
LNK/ACT	Green	Lights to indicate the link through that port is successfully established. Blinks to indicate that Switch is actively sending or receiving data over that port.

## 2.2 Rear Panel

The rear panel of the FNSW-4800 indicates an AC inlet power socket, which accepts input power from 100 to 240V AC, 50-60Hz, and 0.6A max.



**Figure 2-2** FNSW-4800 Switch rear panel



Note

1. The device is a power-required device, it means, it will not work till it is powered. If your networks should active all the time, please consider using UPS (Uninterrupted Power Supply) for your device. It will prevent you from network data loss or network downtime.
2. In some area, installing a surge suppression device may also help to protect your FNSW-4800 from being damaged by unregulated surge or current to the FNSW-4800.

## 2.3 Hardware Installation

This part describes how to install your FNSW-4800 and make connections to the Switch. Please read the following topics and perform the procedures in the order being presented. To install your Switch on a desktop or shelf, simply completed the following steps.

### 2.3.1 Desktop Installation

To install a Switch on a desktop or shelf, simply completed the following steps:

- Step 1: Attached the rubber feet to the recessed areas on the bottom of the Switch.
- Step 2: Place the Switch on a desktop or shelf near an AC power source.
- Step 3: Keep enough ventilation space between the Switch and the surrounding objects.



Note

When choosing a location, please keep in mind the environmental restrictions discussed in Chapter 1, Section 4, Specification.

Step 4: Connect your Switch to network devices.

- A. Connect one end of a standard network cable to the 10/100 RJ-45 ports on the front of the FNSW-4800 Switch.
- B. Connect the other end of the cable to the network devices such as printer servers, workstations or routers...etc.



Note

Connection to the Switch requires UTP Category 5 network cabling with RJ-45 tips. For more information, please see the Cabling Specification in Appendix A.

Step 5: Supply power to the Switch.

- A. Connect one end of the power cable to the Switch.
- B. Connect the power plug of the power cable to a standard wall outlet then power on the Switch.

When the Switch receives power, the Power LED should remain solid Green.

### 2.3.2 Rack Mounting

To install the Switch in a 19-inch standard rack, follow the instructions described below.

Step 1: Place your Switch on a hard flat surface, with the front panel positioned towards your front side.

Step 2: Attach a rack-mount bracket to each side of the Switch with supplied screws attached to the package. Figure 2-3 shows how to attach brackets to one side of the Switch.

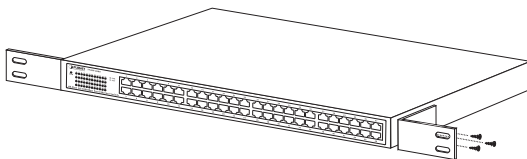

**Figure 2-3** Attaching the brackets to the Switch



Caution

You must use the screws supplied with the mounting brackets. Damage caused to the parts by using incorrect screws would invalidate your warranty.

- Step 3: Secure the brackets tightly.
- Step 4: Follow the same steps to attach the second bracket to the opposite side.
- Step 5: After the brackets are attached to the Switch, use suitable screws to securely attach the brackets to the rack, as shown in Figure 2-4.

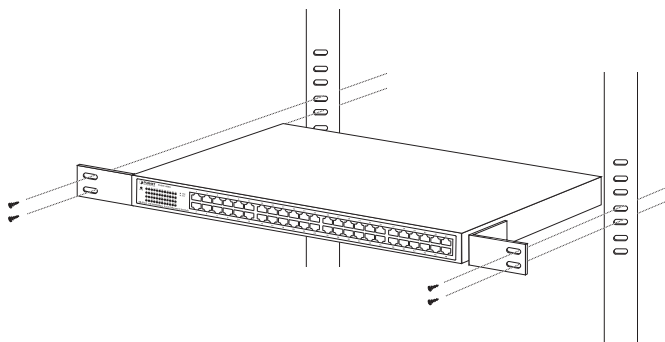

**Figure 2-4** Mounting the Switch in a Rack

- Step 6: Proceed with the steps 4 and steps 5 of section 2.3.1 Desktop Installation to connect the network cabling and supply power to your Switch.

---

## **3. Switch Operation**

### **3.1 Address Table**

The Switch is implemented with an address table. This address table composed of many entries. Each entry is used to store the address information of some node in network, including MAC address, port no, etc. This information comes from the learning process of Ethernet Switch.

### **3.2 Learning**

When one packet comes in from any port. The Switch will record the source address, port no. And the other related information in address table. This information will be used to decide either forwarding or filtering for future packets.

### **3.3 Forwarding & Filtering**

When one packet comes from some port of the Ethernet Switching, it will also check the destination address besides the source address learning. The Ethernet Switching will lookup the address-table for the destination address. If not found, this packet will be forwarded to all the other ports except the port which this packet comes in. And these ports will transmit this packet to the network it connected. If found, and the destination address is located at different port from this packet comes in, the Ethernet Switching will forward this packet to the port where this destination address is located according to the information from address table. But, if the destination address is located at the same port with this packet comes in, then this packet will be filtered. Thereby increasing the network throughput and availability.

### **3.4 Store-and-Forward**

Store-and-Forward is one type of packet-forwarding techniques. A Store-and Forward Ethernet Switching stores the incoming frame in an internal buffer, do the complete error checking before transmission. Therefore, no error packets occurrence, it is the best choice when a

---

network needs efficiency and stability.

The Ethernet Switch scans the destination address from the packet-header, searches the routing table provided for the incoming port and forwards the packet, only if required. The fast forwarding makes the switch attractive for connecting servers directly to the network, thereby increasing throughput and availability. However, the switch is most commonly used to segment existing hubs, which nearly always improves overall performance. An Ethernet Switching can be easily configured in any Ethernet network environment to significantly boost bandwidth using conventional cabling and adapters.

Due to the learning function of the Ethernet switching, the source address and corresponding port number of each incoming and outgoing packet are stored in a routing table. This information is subsequently used to filter packets whose destination address is on the same segment as the source address. This confines network traffic to its respective domain, reducing the overall load on the network.

The Switch performs "Store and Forward" therefore, no error packets occur. More reliably, it reduces the re-transmission rate. No packet loss will occur.

### 3.5 Auto-Negotiation

The STP ports on the FNSW-4800 switch have built-in "Auto-negotiation". This technology automatically sets the best possible bandwidth when a connection is established with another network device (usually at Power On or Reset). Detecting the modes does this and speeds at the second of both devices are connected and capable of, both 10Base-T and 100Base-TX devices can connect with the port in either Half- or Full-duplex mode.

If attached device is:	100Base-TX port will set to:
• 10Mbps, no auto-negotiation	10Mbps
• 10Mbps, with auto-negotiation	10/20Mbps (10Base-T/Full-Duplex)
• 100Mbps, no auto-negotiation	100Mbps
• 100Mbps, with auto-negotiation	100/200Mbps (100Base-TX/Full-Duplex)

## 4. Troubleshooting

This chapter contains information to help you solve issues. If the Switch is not functioning properly, make sure the Ethernet Switch was set up according to instructions in this manual.

### The Link/Act LED is not lit



Solution

Check the cable connection of the Switch.

### Performance is bad



Solution

Check the speed duplex mode of the partner device. The FNSW-4800 is run at Auto-negotiation mode and if the partner is set to half duplex, then the performance will be poor.

### 100Base-TX port link LED is lit, but the traffic is irregular



Solution

Check that the attached device is not set to dedicate full duplex. Some devices use a physical or software switch to change duplex modes. Auto-negotiation may not recognize this type of full-duplex setting.

### Why the Switch doesn't connect to the network



Solution

Check the LNK/ACT LED on the Switch Try another port on the Switch Make sure the cable is installed properly Make sure the cable is the right type Turn off the power. After a while, turn on power again..

## Appendix A Networking Connection

### A.1 Switch's RJ-45 Pin Assignments

#### 10/100Mbps, 10/100Base-TX

Contact	MDI	MDI-X
1	1 (TX +)	3
2	2 (TX -)	6
3	3 (RX +)	1
6	6 (RX -)	2
4, 5, 7, 8	Not used	Not used

### A.2 RJ-45 cable pin assignment

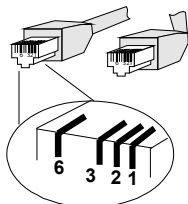

There are 8 wires on a standard UTP/STP cable and each wire is color-coded. The following shows the pin allocation and color of straight cable and crossover cable connection:



Figure A-1 Straight-Through and Crossover Cable

Please make sure your connected cables are with same pin assignment and color as above picture before deploying the cables into your network.

This page is intentionally left blank

[www.planet.com.tw](http://www.planet.com.tw)



**PLANET Technology Corp.**

2011-A50110-001

