



Model CA2458

2.4 to 5.8 GHz Converter/Amplifier System



Installation and Operation Manual

Version 2.6

October 2002

8000 Lee Highway
Falls Church, VA 22042
Tel: (703) 205-0600 Fax: (703) 205-0610
Sales: 1-888-297-9090

www.ydi.com

990 Almanor Avenue
Sunnyvale, CA 94085
Tel: (408) 617-8150 Fax: (408) 617-8151
Sales: 1-800-664-7060

TABLE OF CONTENTS

1.0 DESCRIPTION	1
2.0 CONVERTER (ODU) FEATURES.....	2
3.0 OUTDOOR UNIT SPECIFICATIONS.....	4
4.0 CONVERTER KIT	5
5.0 INSTALLATION INSTRUCTIONS -- INTRODUCTION.....	5
6.0 RADIO FREQUENCY SAFETY	6
7.0 SITE SELECTION AND SYSTEM ENGINEERING.....	6
8.0 OUTDOOR CONVERTER MOUNTING	7
9.0 DC INJECTOR INSTALLATION	7
10.0 TYPICAL ODU INSTALLATION.....	8
11.0 LINK TEST PERFORMANCE	8
12.0 INSTALLATION DETAILS – TYPICAL INSTALLATION.....	8
13.0 CONVERTER INDICATORS AND CONNECTORS	10
14.0 DC POWER INJECTOR.....	10
15.0 DC POWER INJECTOR INDICATORS AND CONNECTORS	11
16.0 POWER SUPPLY	11
17.0 OPERATION	12
APPENDIX A	13
APPENDIX B.....	14
APPENDIX C	16

© 2002 Young Design, Inc. All Rights Reserved. No part or parts of this document may be reproduced, translated, stored in any electronic retrieval system or transmitted in any form or by any means electronic, mechanical, photocopied, recorded or otherwise without prior written permission of Young Design, Inc.

Professional Installation Required

The Model CA2458 Converter/Amplifier, WLAN radio card, antenna, cables and accessories must be installed as a system by experienced antenna installation professionals who are familiar with Radio Frequency (RF) issues such as gains and losses, as well as local building and safety codes. Failure to do so will void the product warranty and may expose the end user to excessive RF hazard. Regulations regarding maximum antenna gains, power output and maximum permissible exposure vary from country to country. It is the responsibility of the end user to operate within the limits of these regulations and to ensure that the professional installers who install this device are aware of these regulations. All antennas are intended to be installed outdoors.

FCC NOTICE

To comply with FCC part 15 rules, the CA2458 Converter/Amplifier must only be used as a system as FCC certified. The system must also be professionally installed to ensure compliance with the Part 15 certification. It is the responsibility of the operator and professional installer to ensure that only certified systems are deployed in the United States (or where FCC rules apply). Further, pursuant to FCC Part 15 regulations, Section 15.247(b)(3)(iii), the installer must ensure that the high-gain directional antenna used in this system is used exclusively for fixed, point-to-point operations and that multiple co-located intentional radiators transmitting the same information are not used. Please visit our web site (www.ydi.com) to see other YDI systems certified by the FCC.

This device complies with Part 15 of the FCC rules. Operation is subject to the following two conditions:

- 1) This device may not cause harmful interference.*
- 2) This device must accept any interference received, including interference that may cause undesired operation.*

SAFETY WARNING

This equipment complies with FCC radiation exposure limits set forth for an uncontrolled environment when installed as directed. This equipment should be installed and operated with fix-mounted antennas that are installed such that the main lobe(s) of these antennas are located at a minimum of 2 meters between the antenna and all persons during normal operation

LIMITED WARRANTY

Young Design, Inc. (YDI) warrants that your device is free of defects in material and workmanship for a period of one year after initial purchase. YDI will, in this period, repair or replace any YDI product returned to the factory, freight prepaid.

The YDI warranty covers repairs or replacement (at YDI's option) of the product only. YDI is not responsible for the cost of removal, reinstallation or shipping to the place of repair. YDI does not extend or modify its warranty period as a result of repair or replacement.

YDI reserves the right to void a warranty and/or make reasonable charges for repair of a unit if the warranty seal is broken or the unit displays evidence of misuse, abuse or tampering.

YDI is not responsible for damage to any other equipment or property, or any other consequential or incidental damages of any kind, whether based on contract, negligence or strict liability. Maximum liability shall not in any case exceed the purchase price of the unit.

Warranties give you (the buyer) specific legal rights. You may also have other rights that vary from state to state. This warranty is only extended to purchases made in the United States of America or its possessions.

Special Warranty Notice

The CA2458 Converter/Amplifier warranty is null and void if any of the following occurs:

1. The Converter or WLAN card are opened.
2. The Converter or any part of the system is installed improperly.
3. The Converter is operated with no antenna attached.
4. The Converter is over-driven or operated with no antenna attached while transmitting.
5. The Converter is operated outside the recommended DC power.
6. The antenna connections are not properly waterproofed.
7. The installers use improper connectors.

Installation and Operation Manual

CA2458 Converter/Amplifier System

1.0 Description

The CA2458 Converter/Amplifier system is a bi-directional wireless data link operating in the 5.8 GHz band. It makes use of existing 802.11b wireless technology up-converted to the 5.8 GHz unlicensed band. The system consists of an 802.11b wireless LAN card, a 5.8 GHz frequency block converter (the outdoor unit or ODU), antennas and accessories.

The CA2458 Converter/Amplifier (Converter or CA2458) outdoor unit provides bi-directional linear frequency block conversion (translation) from the 2.4 GHz band to the 5.8 GHz band. As a system, it allows the use of existing 2.4 GHz WLAN equipment on the 5.8 GHz band. The Local Oscillator (LO) operates at 3.328 GHz. This means a 2.412 GHz signal will go out over the air at 5.740 GHz. Currently, the 5.8 GHz band provides relief from interference that is present on 2.4 GHz in many geographic areas and also allows the use of this band for backbone or backhaul use.

All functions of the CA2458 ODU are transparent to the user. No adjustments of any kind are required. Channel assignment and network set-up are both performed at the radio card (or access point).

Installation of the CA2458 requires outdoor mounting of the Converter (at the antenna) and indoor installation of the WLAN card, DC Injector and power supply. Coaxial cable carries both DC power and the RF signal from the DC Injector to the Converter. All signals passing between the DC injector and Converter are at a frequency of 2.4 GHz to minimize cable attenuation.

2.0 Converter (ODU) Features

- Transmit input levels from +3 dBm to +10 dBm
- 14 dB transmitter conversion power gain
- 12 dB receive conversion gain
- RX preamp noise figure 4.5 dB (typical)
- Mast mounted weatherproof cast aluminum case
- DC power carried up through the transmission cable
- Power and transmit LEDs on both the Converter and the DC Power Injector
- Built-in lightning protection
- DC surge protection
- Heavy duty N-type connectors
- One-year warranty
- Made in the U.S.A

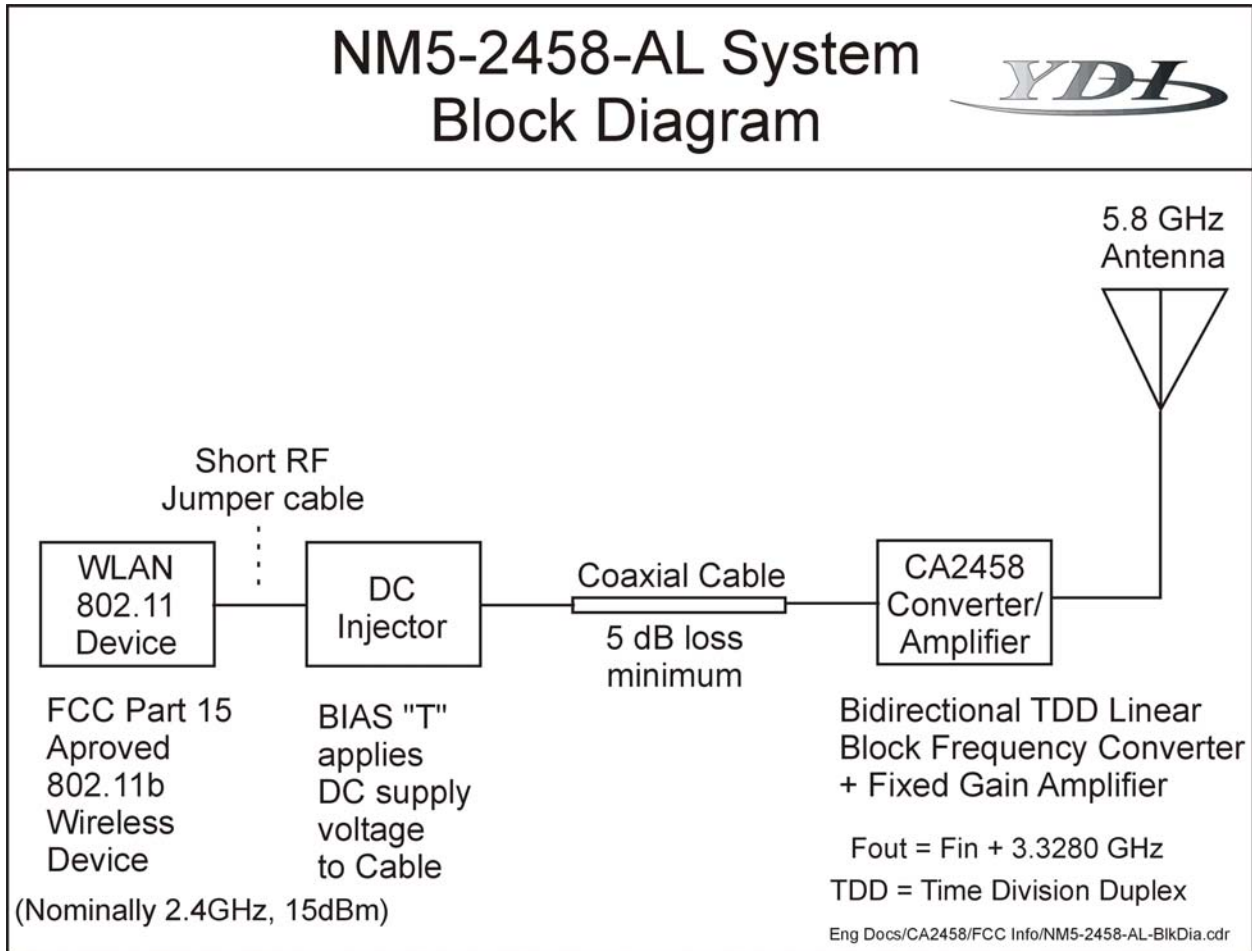



Converter/Amplifier System

3.0 Outdoor Unit Specifications

General Specifications

Operating Range: At radio port: 2400-2483 MHz
At antenna port: 5725-5850 MHz

LO Frequency: 3328 MHz

Operating Mode: Bi-directional, half-duplex. Senses RF carrier from transmitter and automatically switches from receive to transmit mode.

Connectors: N-female

Indicators: TX and RX LEDs on both the Converter and the DC power injector

Lightning Protection: Direct DC ground at antenna connector. DC injector serves as lightning arrestor if properly grounded.

Transmitter Amplifier

DC Surge Protection: 600 Watt TVS at 15 VDC input from transmission cable

Transmit Conversion Gain: 14 dB typical

Frequency Response: +/-1.5 dB over operating range

Transmit Output Power: 250 mW typical for optimum linearity

TX Duty Cycle: 50% Maximum

Transmit Input +3 dBm to +8 dBm for optimum linearity

Power at Converter: +20 dBm absolute maximum for no damage

Receiver Low Noise Amplifier (LNA)

Conversion Gain: 12 dB typical

Frequency Response: +/-3 dB over operating range

Noise Figure: 4.5 dB typical, 6.0 dB max at room temperature

Mechanical, Power and Environmental

Operating Temperature:	-20 deg C to +60 deg C
Dimensions:	Converter/Amplifier: 6.95" x 3.14" x 2.24 "
	DC Power injector: 5.4" x 2.4" x 1.3 "
Power:	100 to 240 VAC when using the power supply provided - or - 13.8 to 15 VDC @ 1.3 Amp peak. Note: DC power supply must be rated at least 2 amps.
Outdoor Mounting Bracket:	Accommodates pole/mast diameters from 3/4" to 3"
Kit Weight:	Approx. 3.5 lb. with U-bolts

4.0 Converter Kit

Each CA2458 Converter kit contains the following:

- Pole mounted CA2458 Converter/Amplifier Outdoor Unit
- DC Power Injector
- 15 VDC Power Supply, 100 to 240 VAC
- Mounting U-bolt with nuts and lock washers
- Installation and Operation Manual
- YDI Diamond WLAN card and adapter cable (purchased together or separately)

5.0 Installation Instructions -- Introduction

Several key factors unique to the particular installation determine the power level at the input of the Converter/Amplifier ODU. The most important consideration is the cable loss in the transmission cable between the radio and the remotely mounted Converter/Amplifier. **It is imperative that the professional installer be knowledgeable about these and other factors when installing the system.**

IMPORTANT: It is vital that the Converter not be over-driven in the transmit mode. Doing so will cause it to go into compression resulting in increased transmitter noise and severe interference to adjacent channels without *any* increase in range or Signal to Noise Ratio (SNR).

IMPORTANT: If you or your installer are not familiar with determining power levels within the transmission system, YDI engineers will assist you in planning your system including selecting the cable and antenna required.

6.0 Radio Frequency Safety

It is the responsibility of the installer and the owner of the equipment to ensure that the installation complies with government standards for Radio Frequency (RF) and Electromagnetic Field exposure.

Please refer to OET Bulletin 65, "Evaluating Compliance with FCC Guidelines for Human Exposure to Radio Frequency Electromagnetic Fields." This document is available on the Federal Communications Commission website at www.fcc.gov.

7.0 Site Selection and System Engineering

Selection of a site and proper system engineering are vital for a successful installation of the system. The following are general guidelines to follow for proper operation:

- The radio path must provide line of sight with no obstruction or Fresnel Zone incursion.
- Antenna polarization must be the same on both ends of the link.
- A path analysis must be performed to ensure that the correct antenna gains have been selected.
- The System Operating Margin must be maintained at a level above 14 dB.

Several types of system calculations may be performed on-line at the YDI website. Please visit www.ydi.com and click on **Calculations Page**. For additional technical support, please call (703) 205-0600.

8.0 Outdoor Unit Mounting

The Converter can be mast mounted using the steel U-bolt included with the unit. Refer to Section 12.0 of this manual, ***Installation Detail - Typical Installation***, for a cabling diagram. The Converter must be installed with the N-type connectors facing downward. Use an open-end wrench to tighten the bolts with the nuts included in the kit. Be careful not to over-tighten the bolts.

It is imperative to waterproof the RF connectors on the Converter. However, we recommend that you do not seal the connectors until after all system tests have been performed. Ensure that a high quality weather resistant electrical tape and/or other water sealant method is used. A “drip loop” should be used on the coaxial cable where it enters the building. Silicon sealants are not recommended since they are difficult to work with, do not ensure a 100% waterproofing of the connectors and are hard to remove if ever necessary.

The antenna and Converter must be mounted as far away as possible from other radio transmitters, regardless of their frequency range. There must be no obstructions in front of the antenna or in the antenna Fresnel Zone.

A good ground connection must be established. If the mast and/or tower are properly grounded, an adequate ground connection will be provided by the Converter’s mounting bracket. If additional grounding is desired, a cable grounding kit should be used where the coax cable enters the building.

NOTE: Do not add any additional lightning protection between the DC Injector and the Converter. It will block or short the DC power going to the Converter.

9.0 DC Injector Installation

The DC injector mounting location is not critical, but it must be located indoors as it is not weatherproof. Attach the DC injector to a flat surface using screws or bolts through the mounting flanges. Use only the supplied DC power supply or a well regulated 15-volt supply with a current rating of at least 2.0 Amperes.

It is important to provide a good ground for protection against lightning and surges. Connect a #12 AWG or larger ground wire to the ground stud on the DC injector.

10.0 Typical ODU Installation



The picture to the left shows the Converter in a typical installation with a 2-foot dish antenna. The Converter should connect to the antenna with the shortest possible cable. The location on the mast where it is mounted is not important, provided that the connectors face downward. (Note that when this picture was taken, the connectors were not yet weather proofed nor was the cable secured to the mast.).

The cable connecting the Converter to the antenna should not exceed 2 feet in length if LMR400 cable is used.

In addition, there is no need to plug or fill any of the holes on the back of the Converter enclosure. The housing is designed so that these holes do not penetrate the inside of the waterproof seal.

If the tower or mast is adequately grounded and the U-bolt makes a good electrical connection to it, there is no need to provide additional grounding to the amplifier enclosure.

11.0 Link Test Performance

Link tests were performed at 18 miles with a clear line of sight and Fresnel Zone. A Signal to Noise Ratio (SNR) in excess of 20dB was achieved. The test was set up according to the **Installation Details** diagram in Section 12.0 using the following equipment:

- ORiNOCO ROR
- YDI Diamond WLAN Card
- RF Adapter Cable (LUNM)
- CA2458 Converter/Amplifier
- 75 feet of LMR400 cable between the DC Injector and the Converter
- 2-foot Dish Antennas with 27dBi gain

12.0 Installation Details – Typical Installation

The following diagram on page 10 illustrates the installation details of the Converter.

INSTALLATION DETAILS

CA2458 Converter/Amplifier with 2.4 GHz Radio

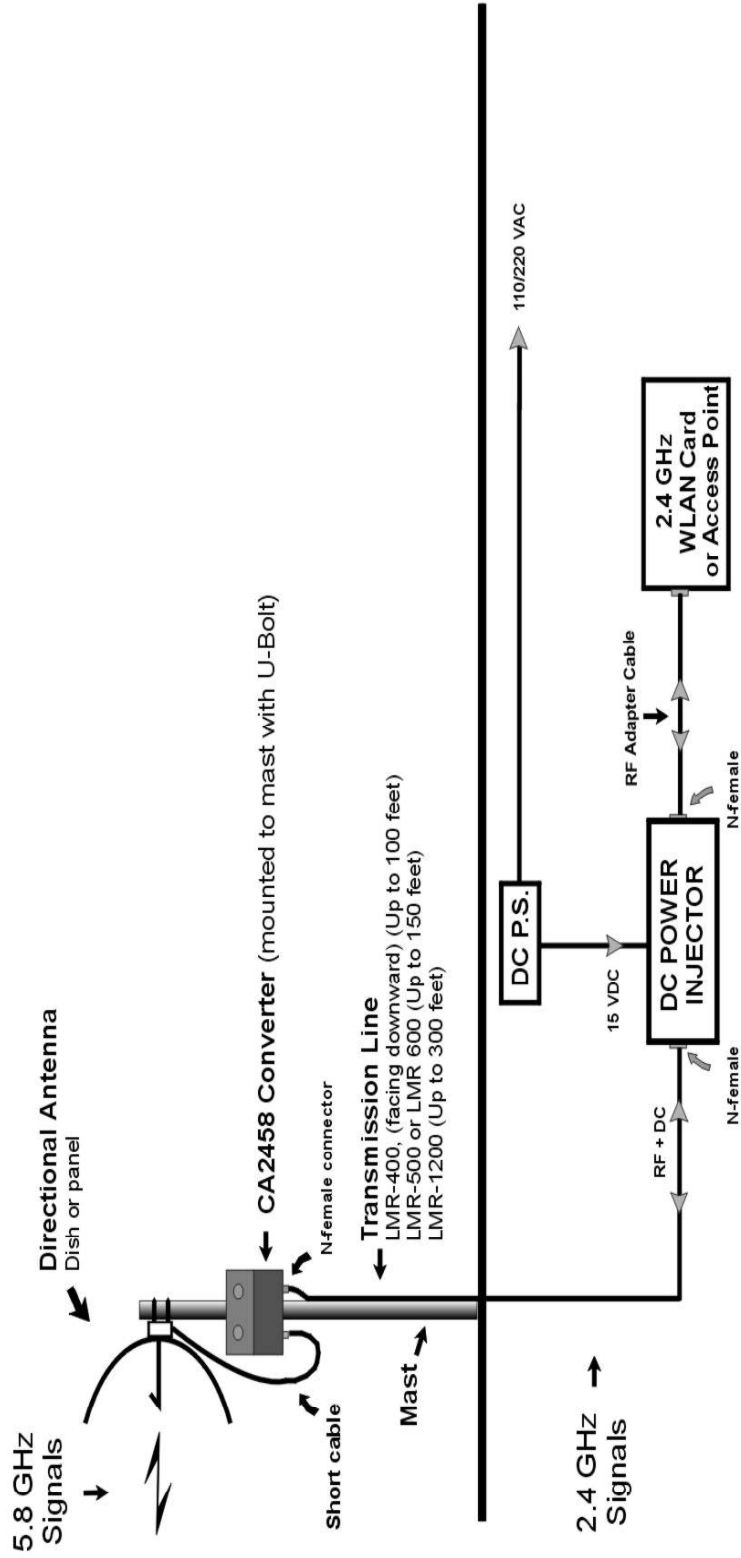

YDI can provide all necessary cables, antennas and accessories. The professional installer must provide the mast or pole to mount the antenna and amplifier.

13.0 Converter Indicators and Connectors

CAUTION: Only use high quality N-type connectors. Do not use PL259 “CB” type UHF connectors. Doing so will ruin the N-Female jacks and void your warranty.

Transmit LED:	This LED glows RED when the Converter has switched to the transmit mode. This occurs when the Converter detects RF power at the N-type connector labeled “To DC Injector”.
Receive LED:	This LED glows GREEN in the receive mode when DC power is applied to the Converter/Amplifier. It is turned off when the Converter is in the transmitting mode.
DC Injector Connection:	This N-type female connector attaches to the DC Power Injector via the transmission cable. The length of this cable will determine the type of cable that should be used. See the <i>Installation Detail</i> diagram in Section 12.0 and Appendix B, Table B for more information.
Antenna Connection:	This N-type female connector attaches to the antenna with the shortest length of low-loss coax cable possible.

14.0 DC Power Injector

A DC Power Injector is an in-line device that “injects” the DC power onto the coax cable to provide the power necessary to operate the remotely mounted converter/amplifier. The DC Power Injector is the interface between the WLAN card and the Outdoor Unit. This allows the coax cable to carry both RF signals and DC power to the mast-mounted Converter/Amplifier. This precludes the need to run a separate power cable to the remote mounted Converter/Amplifier.

When grounded to either an earth ground through the grounding stud or mounting flange, the DC Power Injector will provide maximum lightning protection to your radio modem, wireless LAN card or Access Point.

15.0 DC Power Injector Indicators and Connectors

Red Transmit LED:	This LED glows RED when the Converter goes into transmit mode. The Remote Transmit LED is controlled by unique circuitry, which actually detects changes in the DC current traveling through the transmission line to the amplifier. When you see this LED flash, you will know that the remotely mounted Converter is going into transmit mode.
Green Receive LED:	This LED glows GREEN when DC power is applied to the Converter and it is in the receive mode. When toggling between transmit and receive, this LED will glow slightly dimmer.
“To Radio” Connection:	This N-type female connector attaches to the WLAN card via a short jumper cable.
“To Amplifier” Connection:	This N-type female connector attaches to the amplifier on the mast using the coax transmission line.
15 VDC:	This is the DC power input for the injector and is a standard 2.5 mm barrel jack. +15 VDC should be applied with center positive.

16.0 Power Supply

The CA2458 Converter/Amplifier kit comes with a 100 - 240 VAC power supply that has a standard 2.5 mm barrel plug [center pin positive (+) tip and outer ring negative (-)]. Although normally supplied with a power supply, any 15 Volt DC, 2 amp (or greater) regulated power supply can be used. The Converter can operate from 13.8 to 15 VDC enabling vehicle operation as well. The WLAN card receives power from its host device.

The DC power input is diode protected to prevent damage caused by reverse polarity input voltages, as well as by an MOV (surge protector) to protect it and the amp from voltage surges.

17.0 Operation

The system operates automatically and requires no user adjustments. It translates 2.4 GHz signals by 3.328 GHz to and from the 5.7- 5.8 GHz band. For example, a 2.462 GHz signal will go out over the air at 5.790 GHz (See Conversion Table below).

Conversion Table

802.11 Channel	2.4 GHz Freq. (MHz)	5.8 GHz Freq. (MHz)
1	2412	5740
2	2417	5745
3	2422	5750
4	2427	5755
5	2432	5760
6	2437	5765
7	2442	5770
8	2447	5775
9	2452	5780
10	2457	5785
11	2462	5790
12	2467	5795
13	2472	5800

The Converter ODU is only intended for use with 2.4 GHz devices that alternate between transmit and receive on the same radio channel. These are referred to as Time Division Multiplex (TDM) devices. A typical example is an 802.11 WLAN card or Access Point. These modems “ping-pong” back and forth between transmit and receive so quickly during normal operation that both the TX and RX LEDs will appear to be lit simultaneously. You can approximate the duty cycle from the LEDs by their brightness.

The Converter ODU will not work with radio modems or wireless bridges that are band-split true full duplex devices. Presently the ODU is only certified with the YDI Diamond WLAN card as a system.

The Converter provides for linear amplification for transmit output powers up to +24 dBm (250 mW). This is important for Direct Sequence Spread Spectrum (DSSS) radios, especially 802.11 devices. If you drive the Converter in excess of 250mW output power, the amplifier will start to go into compression. This will result in raising the sidebands and thus create interference on adjacent radio channels.

NOTE: Remember that all signals passing between the WLAN card and Converter ODU are at a frequency of 2.4 GHz. Cable calculation must be performed using 2.4 GHz attenuation values.

APPENDIX A

Table A - Conversions from dBm to Watts

dBm	Watts	dBm	Watts
0	1.0 mW	26	400 mW
1	1.3 mW	27	500 mW
2	1.6 mW	28	640 mW
3	2.0 mW	29	800 mW
4	2.5 mW	30	1.0 W
5	3.2 mW	31	1.3 W
6	4.0 mW	32	1.6 W
7	5.0 mW	33	2.0 W
8	6 mW	34	2.5 W
9	8 mW	35	3.0 W
10	10 mW	36	4.0 W
11	13 mW	37	5.0 W
12	16 mW	38	6.0 W
13	20 mW	39	8.0 W
14	25 mW	40	10 W
15	32 mW	41	13 W
16	40 mW	42	16 W
17	50 mW	43	20 W
18	64 mW	44	25 W
19	80 mW	45	32 W
20	100 mW	46	40 W
21	128 mW	47	50 W
22	160 mW	48	64 W
23	200 mW	49	80 W
24	250 mW	50	100 W
25	320 mW	60	1000 W

Table B - Typical Cable Attenuation Values*

Cable Type	Attenuation per 100 ft. at 2.4 GHz (dB)
Belden 9913	8.0
LMR 200	16.8
LMR 240	12.9
LMR 400	6.9
LMR 600	4.4
½" LDF	3.9
½" Superflex	6.1
3/8" LDF	5.9
3/8" Superflex	6.8
1/4" Superflex	9.8

* Values are approximate. Consult the cable manufacturers for exact specifications.

APPENDIX B

FCC Certified Systems

FCC ID#: NM5-2458-AL
(long card with internal antenna)

FCC Certified Systems consist of:

- CA2458 Converter/Amplifier, DC power injector and 15 VDC power supply
YDI Diamond/Emerald/Agere WLAN card
- Outdoor antenna
- Coax cable
- Consult the YDI website for the most current product and certification information.
www.ydi.com

Table A - Authorized Antennas

Model	Antenna Type	Antenna Gain (dBi)	Max EIRP (dBm)	MPE Distance (CM)
A5.8FP23	One foot flat panel	24	48	71
A5.8FP27	Two foot flat panel	27	51	90
A5.8-1'	One foot dish	24	48	71
A5.8-2'	Two foot dish	27	51	71
A5.8HP90-15	90° sector antenna	16	40	25

NOTE:

1. MPE distance figures are based on a conservative "worst case" scenario, i.e. +24 dBm into antenna using formula $S=EIRP/(4\pi R^2)$ and no calculation for duty factor. In practice the minimum distance will be much shorter.
2. The minimum MPE distance has been calculated for the maximum allowed Power Density (S) limit of 1.0 mW/cm² in the Frequency range 1,500-100,000 MHz uncontrolled environments (See Reference 2.).

References:

1. FCC Part 15, sub-clause 15.247(b)(4)
2. FCC OET Bulletin 65, edition 97-01
3. FCC Supplement C to OET Bulletin 65, edition 97-01

APPENDIX B (Continued)

Table B - Authorized Cables with Minimum Lengths

Cable Type	Minimum Length	Maximum Recommended Lengths
RG58/U LMR195	25 feet	40 feet
LMR200	30 feet	50 feet
LMR240	40 feet	65 feet
LMR400	75 feet	100 feet
LMR500	90 feet	150 feet
LMR600	120 feet	175 feet
LMR900	150 feet	275 feet
LMR1200	200 feet	375 feet
LMR1700	300 feet	500 feet

NOTE: This table is for reference only. In order to comply with FCC Part 15 Certification, the installer must insure that actual coax cable used between the radio and the Converter/Amplifier has at least 5 dB of insertion loss.

CAUTION: The transmit input power to the remote mounted converter must be limited to 10 dBm or less to prevent the Converter/Amplifier from going into compression.

APPENDIX C

Calculating Transmit Power

The following information explains how to calculate the input and output power to and from the Converter:

1. Using Appendix A, Table A, convert the output power of the radio device from milliWatts to dBm. The Model CA2458 Converter ODU is optimized to work with input powers between +3 dBm and +8 dBm.

2. Calculate the cable attenuation at 2.4 GHz as follows:

Determine the attenuation for the length of your cable at 2.4 GHz. Use the cable manufacturer's specifications or, for convenience, refer to Table B for typical values. For example, Table B shows that typical attenuation for LMR-400 is about 7 dB per 100 foot at 2.4 GHz. Add 2 dB of misc. loss for connector, adapter cable and DC injector. Subtract total attenuation from the radio's transmit power.

3. Calculate the maximum power that can be expected at the Converter when mounted on the pole as follows:

$$\text{WLAN card output (dBm)} - \text{Cable loss (dB)} - \text{Misc. Loss} = \text{Signal level @ CA2458 input (dBm)}$$

For example, a radio with +15 dBm output and 75 feet of LMR400 (about 5 dB of loss) would have the following input level to the converter/amplifier:

$$+15 \text{ dBm} - 5 \text{ dB} - 2 \text{ dB} = +8 \text{ dBm}$$

If the input to the Converter exceeds +10 dBm by your calculations, an attenuator pad or a longer/higher loss coax cable will be necessary between the WLAN card and the DC injector. Alternatively, a special version of the Converter may be obtained from YDI that will accept higher transmit input power.

NOTE: Do not attempt to over drive the Converter. Doing so does not only puts the converter into hard compression and does not increase output power. It only raises the sidebands, which pollutes adjacent channels and may result in harmful emissions outside the 5.8 GHz Spread Spectrum band.

Transmit power at 5.8 GHz would then be:

$$+8 \text{ dBm} + 14 \text{ dB} = +22 \text{ dBm}$$

NOTE: Never put attenuator pads in the cable between the DC injector and the Converter/Amplifier since there is a +15VDC voltage on the cable. Doing this would prevent DC power from reaching the amp and will damage the attenuator. A longer cable or one with higher signal loss could be used.

Calculating Effective Isotropic Radiated Power (EIRP)

EIRP is defined as the sum of the power feeding an antenna plus the gain (in dBi) of that antenna. For example, +22 dBm of power into a two foot dish or flat panel antenna with 27 dBi gain would be the following dBm EIRP:

$$+22 \text{ dBm} + 27 \text{ dB} = 49 \text{ dBm (80 watts) EIRP}$$



UNI-POP



EX-1



Amps & Antennas



WIPOP-In-A-Box



Bandwidth Control Unit



EtherAnt II, EtherAnt II-LR



Diamond Card



Lightning Protectors

Your One **STOP** Shop For Complete High-Speed Wireless Internet Systems!!!

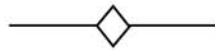

View YDI's Complete Line of High-Speed License Free Wireless Data Products, Antennas and Accessories at:

www.ydi.com

Contact Our Sales Department

Main Office

West Coast Office

8000 Lee Highway
Falls Church VA 22042
Tel: (703) 205-0600 Fax: (703) 205-0610
Sales: 1-888-297-9090

www.ydi.com

990 Almanor Avenue
Sunnyvale, CA 94085
Tel: (408) 617-8150 Fax: (408) 617-8151
Sales: 1-800-664-7060