

---

# TP-SW8-NC

**8 port PoE Endspan (Switch)  
(Extend Ethernet and PoE)**

## USER'S MANUAL



**TYCON POWER SYSTEMS**

---

<b>1. General Information.....</b>	<b>3</b>
<b>2. Hardware Description.....</b>	<b>3</b>
LED Indicators.....	3
Power Wiring .....	5
Ethernet Port Wiring.....	6
PD Port Wiring.....	8
<b>3. Technical Specification.....</b>	<b>9</b>

# 1. General Information

The TP-SW8 POE Switch family provides a PoE/Data input port that is compatible with 802.3af and 802.3at (Type 1 and Type 2) and it has seven 10M/100M TX ports with PoE PSE function. In addition to the ability to accept standard 48VDC power on the Ethernet input Port 8, the TP-SW8-NC provides 2 secondary DC wire terminal input ports for PoE switch operation from 12VDC to 58VDC. PoE output voltage is equal to the input voltage, making this switch a universal voltage PoE switch. The PoE Switch can be used as an Ethernet/PoE repeater to extend Ethernet data and DC power up to 200 meters. This manual will help you install and maintain the PoE switch. Installation of the PoE switch is very easy and you will begin to operate as soon as you are powered up.

The TP-SW8-NC comes with DIN rail mounting adapters for ease of mounting in network cabinets.

# 2. Hardware Description

## \*LED Indicator

There are 18 LEDs on the PoE switch to indicate the power and operational status. The following section describes the functions of each LED indicator.



5	6	7	8
1	2	3	4

Front panel detail  
the port number is as the diagram shows.

\*PWR Indicator

LED	STATUS	Description
Power	Green	LED ON if power input has valid power supplied. (via the terminal block on rear panel or Port 8 on front panel)
	Red	LED ON if the following condition happens. *Power input under voltage (Vin<12V) *Power input over voltage (Vin>58V) *PoE over current(2A)
	Off	No power in DC input

\*SWITCH indicator (the right LED on RJ45)

LED	STATUS	Description
P1~P8 Link/Act	Green	A network device is detected at 100Mbps, but no communication activity is detected.
	Green Blinking	This port is transmitting to, or receiving package from another device at 100Mbps.
	Yellow	A network device is detected at 10Mbps, but no communication activity is detected.
	Yellow Blinking	This port is transmitting to, or receiving package from another device at 10Mbps.
	Off	No device is detected.

\*PoE indicator (the left LED on RJ45)

LED	STATUS	Description
P1~P7 PoE PSE	Yellow	LED ON when PoE power output.
	Off	No PoE output
P8 PoE PD	Yellow	4 pairs power source receive.
	Yellow Blinking	2 pairs power source receive.
	Off	No power is detected on this port.

### \*Power wiring

The PoE switch accepts input voltage from terminal block (rear panel) or RJ45 cable (port 8). If power input from terminal block, the input voltage must be in the range of 12 to 57 VDC. Input current on secondary wire terminal input is 10A max.

If power input from the RJ45 cable (port8), the input voltage must be in the range of 44 to 57VDC if running for 802.3af operation or 50 to 57VDC if running for 802.3at operation. Input current on port 8 is 2A max.

If the TP-SW8-NC is not powered within the above designated input voltage, it will only function as an Ethernet switch without PoE output.

The PoE PSE ports will deliver DC power over the spare pairs as the connection:

- \* TX on lines 1 and 2
- \* RX on lines 3 and 6
- \* V+ on line 4 and 5
- \* V- on line 7 and 8

The Port 8 may get power over the signal pair or spare pairs, the connection as:

- \* Data pair A plus V+ /V- on lines 1 and 2
- \* Data pair B plus V-/V+ on lines 3 and 6
- \* V+/V- on line 4 and 5

\* V-/V+ on line 7 and 8

Rear panel terminal block wiring detail:

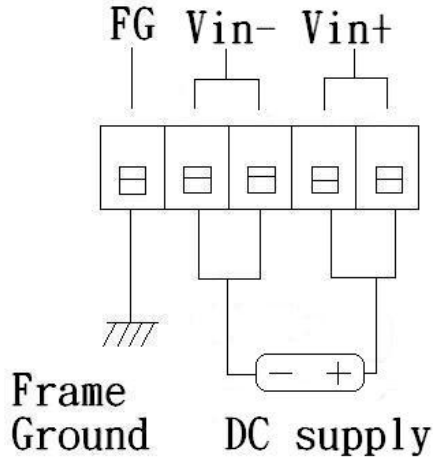

You may use the TP-SW8-NC with our AC adaptor products as the below: (OPTION)

	PSHP-18	PSHP-24	PSHP-48
Maximum output	18VDC/7.5A	24VDC/6.25A	48VDC/3.125A
Related model	TP-SW8-NC	TP-SW8-NC	TP-SW8 TP-SW8-NC

### \*Ethernet Port/PD Port Wiring

The PoE Switch supports Port 1 to Port 8 with automatic MDI/MDI-X crossover, autosense of the speed and duplex for 10Base-T or 100Base-TX connections. Automatic MDI/MDI-X crossover allows you to connect to other devices (switches, hubs, or workstations etc.), without regard to using straight-through or crossover cabling.

Port 1 to port 7 also provides Power over Ethernet function which delivers DC power through the spare pairs (pair 4,5 and pair7,8) to the PD. Port 8 provides Power Device function that receive

power from 4 pairs or 2 pairs Ethernet cable.

Connect an Ethernet cable into any switch port and connect the other side to your attached device. The green or yellow Link/Act LED will light up when the cable is correctly connected. Refer to the **LED Indicator** section for descriptions of each LED indicator.

If a port LED is off, go back and check for connectivity problems between that port and the network device it is connected to.

The maximum cable length for 10/100BaseT with Cat 5 twisted pair cables is typically 100 meters (328 ft.).

### 3. Network Application

The PoE Switch can receive power from PoE midspan and provide power to the PD. It will power 802.3af compliant devices if it is powered at 48VDC although it will not perform the 802.3af handshake with the client device. The PoE Switch can be installed in a more appropriate position for better performance to extend Ethernet to 200 meters. The following figure is an example of a network application for PoE Switch.

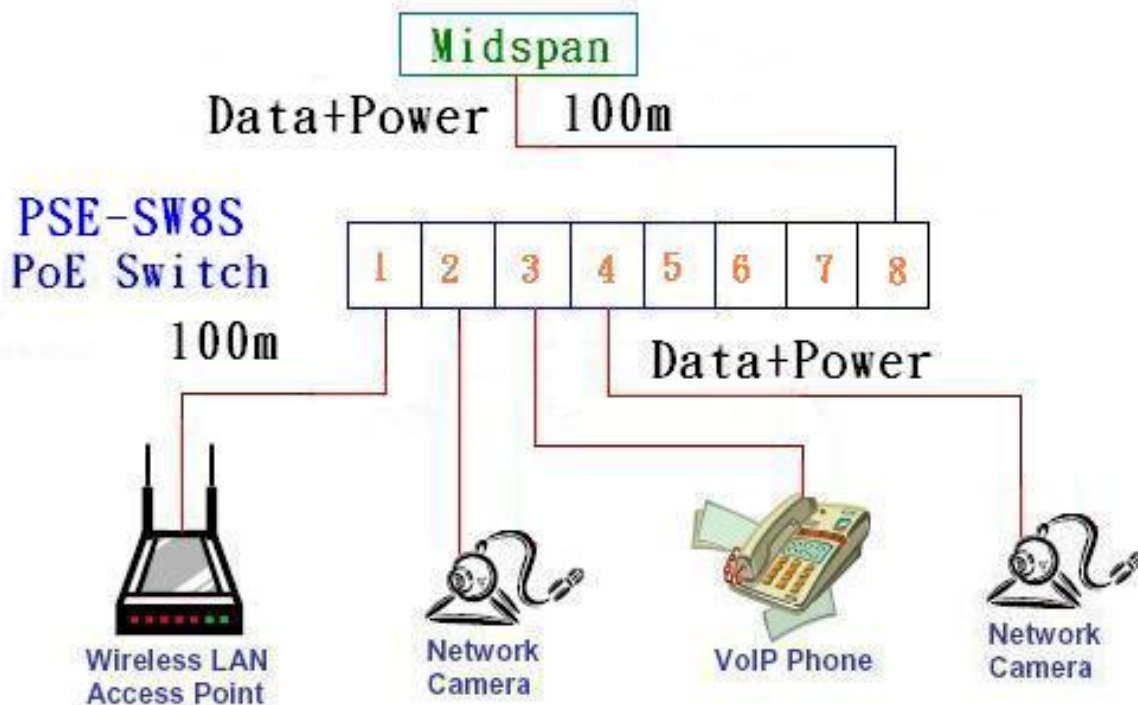

### 3. Model Information

Model	Input Voltage (REAR)	Input Voltage (Port 8)	Output voltage	802.3af/at
TP-SW8-NC	12-57VDC	42.5-57VDC	12-57VDC (non-regulated)	No
TP-SW8	40-57VDC	42.5-57VDC	56VDC (regulated)	Yes

### 4. Technical Specifications

Standards	IEEE802.3/IEEE802.3u standards (10 base-T/100base-T)
Ports	8 ports with 7 PoE PSE & 1 PoE PD, supports auto-crossover & auto-polarity
Transmission speed	100 Mbps(100base-T),10 Mbps(10base-T) Auto-negotiation
Switch technology	store-and-forward
Protocols	CSMA/CD
Flow control	IEEE802.3x(full-duplex),back pressure(half-duplex)
Data transmission rate	148800pps for 100base-T, 14880pps for 10base-T
Address table	2K MAC address table, self-learning
Connect	RJ-45
PoE port	Port 1-7, Pin assignment: TX(1,2), RX(3,6), V+(4,5), V-(7,8) Port 8, 4 pairs PD
Maximum PoE power	Port 1-7: 2 A per port with 12-57V input power supply, 10 A

---

	Maximum total power Port 8: 90W (802.3at 2 event classification)
PoE protection	Over-current, over/under voltage
LEDs	*Link/Activity (Green ON/ Green Blinking @100Mbps/ Yellow/Yellow Blinking @10Mbps) *PoE (Yellow) port 1-4 ON - PD detect Port 5 ON – 4 pair power, Blinking-2 pair power *POWER Green-normal, Red-alarm
Power input	DC(12V~57V) from rear panel or DC(44V~57V) port 8 from midspan (or network switch)
Power consumption	5W without PD loading
Operating temperature	-10°C~ 70°C
Operation humidity	90% relative humidity, non-condensing
Storage temperature	-40°C~+85°C
Dimension	40mm(H)x116mm(W)x159mm(D)