



Installation and Management

TsunamiTM

**ETHERNET BRIDGE
SPREAD SPECTRUM RADIOS
(2.4 AND 5.8 GHz)**

Copyright © 1999, 2000 & 2001 by Western Multiplex Corporation. Copyright © 2004, 2005 Proxim Corporation. All rights reserved. No part of this manual may be reproduced without prior written permission from Proxim Corporation.

The information contained in this manual is subject to change without notice. Proxim Corporation shall not be liable for errors contained herein or for incidental or consequential damages in connection with the furnishing, performance, or use of this manual or equipment supplied with this manual. Proxim Corporation makes no warranty of any kind with regard to this manual or any equipment supplied with this manual, including, but not limited to, the implied warranties of merchantability and fitness for a particular purpose.

Helix™ is a registered product of Andrews Corporation

SmartBits™ is a registered product of NetCom Corporation

Chariot™ and QCheck™ are registered products of Ganymede Software Inc.

other names are trademarks of their owners

Printed in the United States of America

Notice: Y2K (Year 2000 Issue)

All software supplied by and for Proxim Corporation products adheres to the four-(4) digit year nomenclature as required for Year 2000 compliance.

If you are having a problem using a Proxim WAN product and cannot resolve it with the information in the product documentation, gather the following information and contact Proxim Technical Support:

- What kind of network are you using?
- What were you doing when the error occurred?
- What error message did you see?
- Can you reproduce the problem?

Be sure to obtain an RMA number before sending any equipment to Proxim for repair.

To receive E-mail technical support, be sure to include the serial number of the product(s) in question. The serial number should be on the product and conform to the following format: ##UT##### or ##R7#####. We are unable to respond to your inquiry without this information.

USA & Canada Customers

Call Technical Support: WAN Toll Free

866-674-6626 or

408-542-5390

Hours: 6:00 AM to 5:00 PM M-F Pacific Time

LAN Toll Free

866-674-6626 Hours: 24x7

International Customers

Call Technical Support:

WAN 408-542-5390

Hours: 6:00 AM to 5:00 PM M-F Pacific Time

LAN 408-542-5390 Hours: 24x7

Search Knowledgebase: <http://support.proxim.com/>

Latest software and documentation: <http://support.proxim.com/>

Issue: February 2005

Revision history:

Feb 2000	Added 8Mbps and 12Mbps products
May 2000	Fixed switch settings for 8/12 Mbps radios
July 2000	Added more link-test/loopback detail Added more testing details (Qcheck) Fixed neg/pos power supply table titles Added FCC information Added "Switch" to Ethernet section (Appendix C)
August 2000	Fixed Figure and Table references Removed future product
September	Clarified use of 802.1Q frames (maximum frame size) Fixed Table B-2 for Channel 2 switch settings
October	Added more detail concerning frame size allowance
November	Fixed Figure 3-14 Added pin numbers for 10BaseT, T1 & E1 connectors
April 2001	Added section on typical throughput and equipment Added index pointer to frequency plans
May 2001	Corrected frame length to 1518 bytes with explanation Added safety instruction
January 2005	Adjust ambient temperature maximum specified Replace inaccurate switch settings (Section 5: Appendices) Update front cover, notices, and support information
February 2005	Update switch settings, pages 5-3 through 5-6



Regulatory Notice

This equipment has been tested and found to comply with the limits for a class B digital device, pursuant to Part 15 of the FCC Rules. These limits are designed to provide reasonable protection against harmful interference in a residential installation. This equipment generates, uses and can radiate radio frequency energy and, if not installed and used in accordance with the instructions, may cause harmful interference to radio communications. However, there is no guarantee that interference will not occur in a particular installation. If this equipment does cause harmful interference to radio or television reception, which can be determined by turning the equipment off and on, the user is encouraged to try to correct the interference by one or more of the following measures:

- * Reorient or relocate the receiving antenna.
- * Increase the separation between the equipment and receiver.
- * Connect the equipment into an outlet on a circuit different from that to which the receiver is connected.
- * Consult the dealer or an experienced radio/TV technician for help.

Shielded cables and I/O cords must be used for this equipment to comply with the relevant FCC regulations.

Changes or modifications not expressly approved in writing by Western Multiplex may void the user's authority to operate this equipment.

This device complies with RSS-210 and/or RSS-139 of Industry Canada. Operation is subject to the following two conditions: (1) this device may not cause interference, and (2) this device must accept any interference, including interference that may cause undesired operation of the device.

This device must be professionally installed.

This page intentionally left blank

WARRANTY

GENERAL TERMS

- 1.1 All Definitions contained in Western Multiplex's Conditions of Sale (Western Multiplex document number CS96-8), apply to the Warranty.
- 1.2 Subject to the provisions of the Warranty, Western Multiplex warrants that the equipment described in Paragraph 1.3 shall conform to their specifications described in Paragraph 1.4 in all material respects and that the equipment shall be free from material defects in materials and workmanship.
- 1.3 This Warranty applies to all original purchases of Western Multiplex manufactured equipment and accessories (collectively the "Equipment").
- 1.4 This Warranty applies to the specifications contained in the most recent version of the manual for the model of the Equipment purchased (the "Specifications").
- 1.5 This Warranty does not apply to the following items of Equipment which are covered by the Original Equipment Manufacturer's warranty:
 - (a) antenna systems, including coax cable, waveguide, connectors flex-sections, mounts, other parts of the antenna system and installation materials;
 - (b) non-Western Multiplex manufactured rack mounted equipment that is assembled wired and tested at Western Multiplex's factory or supplied as part of a system, including orderwire items, channel banks, multiplexers, fuse/alarm panels, remote alarm items; and
 - (c) equipment which is not listed in Western Multiplex's price book.
- 1.6 The effective period of this Warranty shall start on the date of shipment of the Equipment and shall end:
 - (a) for all spread spectrum unlicensed radio products and for all licensed digital microwave radio products, two (2) years later;
 - (b) for all analog microwave radio products, three (3) years later; or
 - (c) for all baseband products, five (5) years later (in each case the "Warranty Period").
- 1.7 The Customer acknowledges that Western Multiplex does not represent or warrant that the services provided by Western Multiplex under this Warranty will ensure uninterrupted or error-free operation of the Equipment.

RETURN OF EQUIPMENT UNDER WARRANTY

- 2.1 If an item of Equipment malfunctions or fails in normal intended usage and maintenance within the applicable Warranty Period:
 - (a) the Customer shall promptly notify Western Multiplex of the problem and the serial number of the defective item;
 - (b) Western Multiplex shall, at its sole option, either resolve the problem over the telephone or provide the Customer with a Returned Materials Authorization number (RMA #) and the address of the location to which the Customer may ship the defective item;
 - (c) if the problem is not resolved over the telephone, the Customer shall attach a label to each Returned item describing the fault and the Customer's Return address. The Customer shall, at its cost, properly pack the item to be Returned, prepay the insurance and shipping charges, and ship the item to the specified location;
 - (d) if the Western Multiplex product shall prove to be defective in material or workmanship upon examination by Western Multiplex, Western Multiplex shall either repair or replace the Returned item at its sole option. The replacement item may be new or refurbished; if refurbished, it shall be equivalent in operation to new Equipment. If a Returned item is replaced by Western Multiplex, the Customer agrees that the Returned item shall become the property of Western Multiplex.

- (e) Western Multiplex shall at its cost, ship the repaired item or replacement to any destination within the United States of America by carrier and method of delivery chosen by Western Multiplex. If the Customer has requested some other form of conveyance, such as express shipping, or is located beyond the USA borders, then the Customer shall pay to the cost of return shipment.
- 2.2 Equipment which is repaired or replaced by *Western Multiplex* under this Warranty shall be covered under all of the provisions of this Warranty for the remainder of the applicable Warranty Period or ninety (90) days from the date of shipment of the repaired item or replacement, whichever period is longer.

DEFAULT AND TERMINATION

- 3.1 *Western Multiplex* may immediately terminate this Warranty and all of its performance under this Warranty, upon notification to the Customer, if the Customer:
 - (a) makes any unauthorized modifications to the Equipment;
 - (b) assigns or transfers the Customer's rights or obligations under this Warranty without the written consent of *Western Multiplex*;
 - (c) becomes bankrupt or insolvent, or is put into receivership; or
 - (d) has not paid *Western Multiplex* all amounts for the Equipment, services, or other additional charges within thirty (30) days of receipt of written notice from *Western Multiplex*.
- 3.2 If this Warranty is terminated by *Western Multiplex*, the Customer shall remain liable for all amounts due to *Western Multiplex*.

FORCE MAJEURE

- 4.1 "Force Majeure" has the same meaning as defined in *Western Multiplex's* Conditions of Sale (*Western Multiplex* document number CS96-8).
- 4.2 *Western Multiplex* shall not be responsible for failure to discharge its obligations under this Warranty due to Force Majeure.

LIMITATIONS AND QUALIFICATIONS OF WARRANTY

- 5.1 This Warranty does not apply to any damage, defect or failure caused by:
 - (a) any part of the Equipment having been modified, adapted, repaired, or improperly installed, operated, maintained, transported or relocated by any person other than *Western Multiplex* personnel or a *Western Multiplex* authorized service agent, without *Western Multiplex's* prior written consent;
 - (b) storage or environmental conditions which do not conform to the applicable sections of the appropriate *Western Multiplex* Equipment Manual;
 - (c) failure to conform with the Equipment Installation, Operating and Maintenance Instructions of the appropriate *Western Multiplex* Equipment Manual;
 - (d) external causes, including external electrical stress or lightning, or use in conjunction with incompatible equipment, unless such use was with *Western Multiplex's* prior written consent;
 - (e) cosmetic damage;
 - (f) accidental damage, negligence, neglect, mishandling, abuse or misuse, other than by *Western Multiplex* personnel or a *Western Multiplex* authorized service agent; or
 - (g) Force Majeure.

Please see reverse side for additional limitations on damages.

LIMITATIONS ON DAMAGES (North America)

- 6.1 THE WARRANTY STATED IN THIS DOCUMENT IS THE CUSTOMER'S EXCLUSIVE WARRANTY FOR THE EQUIPMENT; WESTERN MULTIPLEX SPECIFICALLY DISCLAIMS ALL OTHER WARRANTIES OF ANY KIND, EXPRESS OR IMPLIED, INCLUDING ANY WARRANTIES OF FITNESS FOR A PARTICULAR PURPOSE AND OF MERCHANTABILITY.
- 6.2 WESTERN MULTIPLEX SHALL NOT BE LIABLE IN TORT, INCLUDING LIABILITY IN NEGLIGENCE OR STRICT LIABILITY, AND SHALL HAVE NO LIABILITY AT ALL FOR INJURY TO PERSONS OR PROPERTY. WESTERN MULTIPLEX'S LIABILITY FOR FAILURE TO FULFIL ITS OBLIGATIONS UNDER THIS WARRANTY OR ANY OTHER LIABILITY UNDER OR IN CONNECTION WITH THE EQUIPMENT SHALL BE LIMITED TO THE AMOUNT OF THE PURCHASE PRICE OF THE EQUIPMENT. THE REMEDIES STATED IN THIS WARRANTY ARE THE CUSTOMER'S EXCLUSIVE REMEDIES AGAINST WESTERN MULTIPLEX REGARDING THE EQUIPMENT.
- 6.3 EVEN IF WESTERN MULTIPLEX HAS BEEN ADVISED OF THE POSSIBILITY OF THEM, WESTERN MULTIPLEX SHALL NOT BE LIABLE FOR ANY INDIRECT, INCIDENTAL, SPECIAL OR CONSEQUENTIAL DAMAGES, INCLUDING THE COST OF LABOR BY THE CUSTOMER'S OWN EMPLOYEES, AGENTS OR CONTRACTORS IN IDENTIFYING, REMOVING OR REPLACING THE DEFECTIVE ITEM; LOST PROFITS, AND REVENUES; FAILURE TO REALIZE EXPECTED SAVINGS; ANY CLAIM AGAINST A CUSTOMER BY A THIRD PARTY; OR ANY OTHER COMMERCIAL OR ECONOMIC LOSSES OF ANY KIND.
- 6.4 THESE LIMITATIONS AND DISCLAIMERS ARE NOT MADE BY WESTERN MULTIPLEX WHERE PROHIBITED BY LAW.

LIMITATIONS ON DAMAGES (International)

- 6.1 THE WARRANTY STATED IN THIS DOCUMENT IS THE CUSTOMER'S EXCLUSIVE WARRANTY FOR THE EQUIPMENT; ALL OTHER WARRANTIES OF ANY KIND, EXPRESS OR IMPLIED, INCLUDING ANY WARRANTIES OF FITNESS FOR A PARTICULAR PURPOSE AND OF MERCHANTABILITY ARE EXCLUDED TO THE FULLEST EXTENT PERMITTED BY LAW.
- 6.2 WESTERN MULTIPLEX'S LIABILITY FOR FAILURE TO FULFIL ITS OBLIGATIONS UNDER THIS WARRANTY OR IN TORT OR AS A RESULT OF STRICT LIABILITY OR ANY OTHER LIABILITY UNDER OR IN CONNECTION WITH THE EQUIPMENT OR ITS SUPPLY SHALL BE LIMITED, EXCEPT IN RESPECT OF DEATH AND PERSONAL INJURY CAUSED BY WESTERN MULTIPLEX'S NEGLIGENCE, TO THE AMOUNT OF THE PURCHASE PRICE OF THE EQUIPMENT. THE REMEDIES STATED IN THIS WARRANTY ARE THE CUSTOMER'S EXCLUSIVE REMEDIES AGAINST WESTERN MULTIPLEX REGARDING THE EQUIPMENT.
- 6.3 EVEN IF WESTERN MULTIPLEX HAS BEEN ADVISED OF THE POSSIBILITY OF THEM, WESTERN MULTIPLEX SHALL NOT BE LIABLE FOR ANY INDIRECT, INCIDENTAL, SPECIAL OR CONSEQUENTIAL DAMAGES, INCLUDING THE COST OF LABOR BY THE CUSTOMER'S OWN EMPLOYEES, AGENTS OR CONTRACTORS IN IDENTIFYING, REMOVING OR REPLACING THE DEFECTIVE ITEM; LOST PROFITS, AND REVENUES; FAILURE TO REALIZE EXPECTED SAVINGS; ANY CLAIM AGAINST A CUSTOMER BY A THIRD PARTY; OR ANY OTHER COMMERCIAL OR ECONOMIC LOSSES OF ANY KIND.

CONDITIONS OF SALE

DEFINITIONS

- 1.1 In these Conditions, unless there is something in the subject matter or context necessarily inconsistent:
- (a) "Western Multiplex" means Western Multiplex (d.b.a. Western Multiplex), Sunnyvale, CA;
 - (b) "Equipment" means the equipment itemized on the Quotation/Order Acknowledgment;
 - (c) "International" means any location other than United States of America and Canada, including their territories and possessions;
 - (d) "North America" means any location in the United States of America and Canada, including their territories and possessions;
 - (e) "Order Acknowledgment" means the sales order acknowledgment provided by Western Multiplex to the Customer;
 - (f) "Payment Instructions" means Western Multiplex's payment instructions, (Western Multiplex document P197-1);
 - (g) "Quotation" means the quotation signed by an authorized representative of Western Multiplex and provided to the Customer;
 - (h) "Shipping Date" means the actual date on which the Equipment left Western Multiplex's factory at Sunnyvale, CA, U.S.A.;
 - (i) "Warranty" means Western Multiplex's warranty, document W97-1;
 - (j) "Invoice" means the bill of goods prepared by Western Multiplex for the equipment with the shipping and any insurance costs.
- 1.2 Headings have been inserted in these Conditions for convenience of reference only and will not effect their construction.

ENTIRE AGREEMENT

- 2.1 The Quotation, these Conditions of Sale, the Order Acknowledgment, the Payment Instructions and the Warranty shall apply to all sales made by Western Multiplex and shall constitute the entire agreement by Western Multiplex and the Customer (the "Agreement").
- 2.2 Any terms and/or conditions of sale, which may be included on the Customer's purchase order form or any communication from the Customer, that are not identical with the terms and conditions stated in this document shall NOT become a part of the agreement of sale unless expressly agreed to in writing in the Quotation.
- 2.3 Western Multiplex's failure to object to any terms and/or conditions of sale contained in any communication from the Customer shall not be considered as acceptance of such terms and/or conditions or as a waiver of the terms and conditions of sale contained herein.
- 2.4 Western Multiplex shall sell to the Customer, and the Customer shall purchase from Western Multiplex, the Equipment in accordance with the Agreement. Western Multiplex accepts the Customer's purchase orders for Equipment and agrees to deliver the Equipment to the Customer only on the terms of the Agreement.
- 2.5 No variation of the Agreement shall be binding unless agreed to in writing by authorized representatives of Western Multiplex and the Customer.

PRICING

- 3.1 All prices in the Quotation are exclusive of all shipping charges and all applicable taxes including but not limited to, federal, state, local, excise, sales and use taxes.
- 3.2 All prices in the Quotation unless otherwise stated:
- (a) for North American customers are FOB Sunnyvale, CA, USA. (New York Uniform Commercial Code); or
 - (b) for international customers are Ex-Works, Sunnyvale, CA, U.S.A. (Incoterms 1990).
- 3.3 All prices in the Quotation include standard domestic packing, unless a separate line item is provided detailing export or special packing charges.

SHIPPING AND INSURANCE

- 4.1 Western Multiplex shall arrange shipping and insurance when requested by the Customer, and shall bill the Customer for the Equipment with the shipping and any insurance costs as separate items, on an invoice (the "Invoice").
- 4.2 Delivery dates quoted by Western Multiplex are to be considered estimates only. In no event will Western Multiplex be liable for any loss or damage resulting from its failure to deliver products within a specified time.

TERMS OF PAYMENT

- 5.1 The Customer shall pay for all Equipment, including shipping and insurance in accordance with the terms of the Invoice.
- 5.2 All Invoices for North American Customers are due and payable in thirty (30) days from the date of the Invoice.
- 5.3 International Customers shall make payments in accordance with Western Multiplex's Payment Instructions by either:
- (a) providing a wire transfer (telegraphic transfer) for the full amount of the Equipment, shipping and insurance charges contained in the Quotation or the pro-forma Invoice sent to the Customer, prior to the Shipping Date; or
 - (b) establishing an acceptable Letter of Credit (LC) for the full amount of the Equipment, shipping and insurance charges contained in the Quotation prior to the order being booked and accepted by Western Multiplex.
- 5.4 If a Customer fails to pay an Invoice when due, Western Multiplex may, without prejudice to any other remedy, postpone shipments, alter payment terms, terminate the Agreement and charge interest on all overdue amounts the rate of 1.5% per month compounded monthly (or if less, the maximum allowed by law). Upon demand, the Customer shall pay all such interest charges and all reasonable collection fees, including reasonable legal expenses.

SECURITY FOR PAYMENT

- 6.1 If the Customer is located in North America, the Customer grants to Western Multiplex a purchase money security interest in the Equipment to secure the payment of the purchase price of the Equipment and all other amounts due from the Customer.
- 6.2 If the Customer is not located in North America:
- (a) despite delivery and passing of risk in the Equipment and any other provision of these Conditions, the title in the Equipment shall not pass to the Customer until Western Multiplex has received payment in full of the purchase price of the Equipment and all other amounts then due from the Customer, and
 - (b) until the title in the Equipment passes to the Customer:
 - (i) the Customer shall hold the equipment as Western Multiplex's fiduciary agent and bailee, and shall properly store, protect and insure the Equipment and shall identify the Equipment as Western Multiplex property;
 - (ii) if the Customer fails to pay Western Multiplex in accordance with the agreed payment terms, Western Multiplex may require the Customer to deliver up the Equipment to Western Multiplex, and, if the Customer does not, Western Multiplex may enter on the premises where the Equipment is stored and repossess the Equipment; and
 - (iii) the Customer shall not pledge the Equipment by way of security for any, indebtedness of the Customer, but if the Customer does so all moneys owed by the Customer to Western Multiplex shall, without prejudice to any other remedy of Western Multiplex, immediately become due.

CHANGES TO PRODUCT SPECIFICATIONS

- 7.1 Western Multiplex may, without notice to the Customer, make changes to the specifications of Equipment which do not materially affect the quality or performance of the Equipment.

EQUIPMENT CONFIGURATION AND EXPEDITING CHARGES

- 8.1 At the Customer's request, Western Multiplex may, for a fee agreed in advance:
- (a) reconfigure the Equipment; or
 - (b) expedite the Customer's order.

SHORTAGES

- 10.1 The customer shall not make any claim for shortages (which are items that the Invoice does not show are on back-order) after twenty-one (21) days after the date of the Invoice.

RETURNS AND EXCHANGES

- 10.1 The return of defective Equipment is covered by the Warranty .
10.2 The Customer may only return Equipment that is not defective if:
- the Equipment does not correspond with the Customer's purchase order; or
 - the Equipment has been ordered in error by the Customer and Western Multiplex has permitted the Customer to remedy the mistake by ordering the correct equipment and resuming the Equipment and the Customer obtains a Returned Materials Authorization number ("RMA #") from Western Multiplex prior to returning any Equipment.
- 10.3 Western Multiplex reserves the right to charge a fee for returned equipment under Subparagraph 10.2(b) with the amount of the fee being determined prior to an RMA # being given by Western Multiplex.
- 10.4 Authorized returns of equipment under Paragraph 10.2 must be in an undamaged condition, in the original configuration, in the original packing materials and within a time period agreed to when the RMA # was issued.
- 10.5 If the Customer does not comply with the provisions of Paragraphs 10.2, 10.3, and 10.4, the Customer shall pay the full amount of the Invoice.
- 10.6 The party liable for all shipping, insurance and any other expenses incurred by the Customer in returning the Equipment under Paragraph 10.2 and for all loss or damage to the Equipment until received by Western Multiplex, shall be: (a) for all items returned under Subparagraph 10.2(a), Western Multiplex and (b) for all items resumed under Subparagraph 10.2(b), the Customer.

CANCELLATION

- 11.1 If the Customer cancels an order before the Shipping Date, Western Multiplex reserves the right to charge the Customer a cancellation charge up to 100% of the amount of the order.
- 11.2 The Customer shall pay all cancellation charges within thirty (30) days from date of the Invoice.

FORCE MAJEURE

- 12.1 Western Multiplex shall not be liable if its performance of the Agreement becomes commercially impractical due to any contingency beyond Western Multiplex's reasonable control, including acts of God, fires, floods, wars, sabotage, civil unrest, accidents, labor disputes or shortages, government laws, rules and regulations, whether valid or invalid, inability to obtain material, equipment or transportation, incorrect, delayed or incomplete specifications, drawings or data supplied by the Customer or others (collectively "Force Majeure"). In no event of Force Majeure shall Western Multiplex be required to purchase goods from others to enable it to deliver the Equipment under the Agreement.

ENGINEERING AND SYSTEM DESIGN

- 13.1 The Customer is solely responsible for the engineering, design, integration and normal preventative and remedial maintenance of the Customer's system for which Western Multiplex supplies Equipment.
- 13.2 Western Multiplex is not responsible for the satisfactory operation of the Equipment in conjunction with other manufacturer's equipment, nor for any losses which may occur as a result of a failure of the Equipment to operate in conjunction with other manufacturer's equipment.

WARRANTY

- 14.1 All Equipment is covered by the Warranty.
- 14.2 THE WARRANTY CONTAINS LIMITATIONS ON THE CUSTOMER'S RIGHTS AND REMEDIES AGAINST WESTERN MULTIPLEX UNDER THE AGREEMENT. THE CUSTOMER ACKNOWLEDGES HAVING READ, UNDERSTOOD AND AGREED TO THOSE LIMITATIONS.

DAMAGES FOR BREACH OF AGREEMENT

- 15.1 If either party is successful in any litigation between the parties based on the Agreement, the successful party shall recover from the other, in addition to direct damages, the successful party's reasonable attorney's fees and other costs of litigation.

INSOLVENCY OF CUSTOMER, ETC.

- 16.1 Western Multiplex may cancel the Agreement and suspend any further deliveries under the Agreement without any liability to the Customer, and, if Equipment has been delivered but not paid for, the price shall become immediately due and payable despite any other agreement to the contrary if:
- any proceedings in bankruptcy, insolvency, receivership or liquidation are taken against the Customer;
 - the Customer makes an assignment for the benefit of creditors or commits an act of bankruptcy or insolvency;
 - the Customer ceases, or threatens to cease, to carry on the ordinary course of its business, or transfers all or substantially all of its property;
 - the Equipment is seized under any legal process or confiscated; or
 - Western Multiplex in good faith believes that the ability of the Customer to pay or perform any provision of the Agreement is impaired, or that any of the events mentioned above is about to occur.

NOTICE

- 17.1 All requests, instructions and notices from one party to the other must be in writing and may be given via registered post or facsimile transmission to the address of the parties shown on the Quotation or Order Acknowledgment.

EXPORT PROVISIONS

- 18.1 The Customer shall not, whether directly or indirectly (including facilitating a third party) export or re-export the Equipment outside the country in which the Customer has stated these items are to be used without obtaining the licenses required under all applicable rules. The Customer shall indemnify Western Multiplex against any liability incurred by Western Multiplex due to any violation by the Customer of any of the provisions of this Section, but this indemnity shall not apply if the Customer reasonably relies on information supplied to it by Western Multiplex with respect to export licenses. Upon receipt of a governmental consent to export the receiving party shall immediately notify the other in writing.

MISCELLANEOUS

- 19.1 No waiver by Western Multiplex of any breach of this Agreement shall be considered as a waiver of any subsequent breach of the same or any other provision.
- 19.2 Any provision of the Agreement which is, or is deemed to be, unenforceable in any jurisdiction shall be severable from the Agreement in that jurisdiction without in any way invalidating the remaining portions of the Agreement, and that unenforceability shall not make that provision unenforceable in any other jurisdiction.
- 19.3 The rights which accrue to Western Multiplex by virtue of the Agreement shall inure for the benefit of and be binding upon the successors and assigns of Western Multiplex.
- 19.4 The agreement shall be governed by the laws of the State of California including the California Uniform Commercial Code. However Western Multiplex may enforce the provisions of the Agreement in accordance with the laws of the jurisdiction in which the Equipment is situated. The United Nations Convention on the Sale of Goods (The Vienna Convention) shall not apply to the Agreement.
- 19.5 Les parties ont exigés que cette entente soit rédigée en anglais.

Tsunami™

Table of Contents

1. HOW TO USE THIS MANUAL	1-1
1.1 MANUAL ORGANIZATION.....	1-1
1.2 ICONS	1-2
1.3 IMPORTANT SAFETY INSTRUCTIONS	1-3
2. PRODUCT DESCRIPTION	2-1
2.1 GENERAL DESCRIPTION.....	2-1
2.1.1 <i>Response Time and Equipment</i>	2-2
2.2 SPECIFICATIONS.....	2-3
2.2.1 <i>Transmitter</i>	2-3
2.2.2 <i>Antenna / Antenna Coupling Unit</i>	2-4
2.2.3 <i>Receiver</i>	2-4
2.2.4 <i>System (Single Hop Performance)</i>	2-5
2.2.5 <i>Digital Line Interface</i>	2-8
2.2.6 <i>Auxiliary Connections</i>	2-10
2.2.7 <i>Temperature and Environment</i>	2-11
2.2.8 <i>Power</i>	2-11
2.2.9 <i>Regulatory Information</i>	2-12
2.2.10 <i>Mechanical</i>	2-12
2.3 FRONT PANEL DESCRIPTION	2-13
2.3.1 <i>General</i>	2-13
2.3.2 <i>Test Points / Power Indicator</i>	2-14
2.3.3 <i>Alarm and Status Indicators</i>	2-15
2.3.4 <i>Controls</i>	2-16
2.3.5 <i>Connections</i>	2-17
2.4 REAR PANEL DESCRIPTION	2-18
2.4.1 <i>RF Connection</i>	2-19
2.4.2 <i>DATA Connections</i>	2-20
2.4.3 <i>Auxiliary Data Connections</i>	2-20
2.4.4 <i>Switches</i>	2-21
2.5 INSTALLATION ACCESSORIES.....	2-23
3. INSTALLATION & ADJUSTMENTS	3-1
3.1 SHIPPING CONTAINER	3-1
3.2 PACKING ITEMS IDENTIFICATION	3-2
3.3 BEFORE INSTALLATION TASK LIST	3-3
3.3.1 <i>Site Selection Requirements</i>	3-3
3.3.2 <i>Line-of-Sight and Path Clearance Guidelines</i>	3-4
3.3.3 <i>RSL Calculation and Link Budget</i>	3-5
3.3.4 <i>Fade Margin Calculation</i>	3-6
3.3.5 <i>Availability Calculation</i>	3-7
3.3.6 <i>Frequency Plan Determination</i>	3-8
3.3.7 <i>Power Supply Planning</i>	3-9
3.3.8 <i>Antenna Planning</i>	3-10
3.4 TOOLS REQUIRED	3-11
3.5 FREQUENCY CHANNEL PLANS	3-12
3.6 MOUNTING THE TSUNAMI.....	3-14

3.7	POWER CONNECTION AND WIRING.....	3-15
3.7.1	DC Power Wiring	3-16
3.7.2	AC Power Connection	3-18
3.8	ANTENNA CONNECTION.....	3-19
3.9	TRANSMISSION LINE CONNECTION	3-20
3.10	ANTENNA INSTALLATION & ALIGNMENT.....	3-21
3.11	ETHERNET INTERFACE CONNECTION	3-24
3.12	DIP SWITCH SETTINGS	3-25
3.12.1	Channel Selection	3-25
3.12.2	Spreading Code Selection.....	3-26
3.13	SYSTEM TURN-UP TO SERVICE	3-27
3.13.1	Output Power Adjustment.....	3-35
3.13.2	Link Testing	3-36
3.13.3	Error LED Mode Selection.....	3-37
3.14	ADDITIONAL CONNECTIONS.....	3-38
3.14.1	Orderwire Connection and Address Selection.....	3-38
3.14.2	Alarm Connections	3-41
3.14.3	Diagnostics Port Operation.....	3-43
3.14.4	AUX DATA (Digital Service Channel) Connection	3-46
3.14.5	Fail-over option.....	3-47
4.	TROUBLESHOOTING.....	4-1
4.1	REGULAR MAINTENANCE	4-1
4.1.1	THROUGHPUT AND EQUIPMENT.....	4-2
4.2	CHANGING FREQUENCY PLANS	4-3
4.3	USING A SPARE TERMINAL	4-4
4.4	TECHNICAL SUPPORT.....	4-5
4.5	REPAIR POLICY.....	4-6
4.6	FRONT PANEL STATUS LEADS.....	4-7
4.6.1	BER (Bit Error Rate) Alarm	4-8
4.6.2	MUTE Alarm (AIS).....	4-11
4.6.3	RX SYNC (Receiver Synchronization) Alarm.....	4-12
4.6.4	FAN Alarm.....	4-13
4.6.5	RADIO FAIL Alarm.....	4-14
4.6.6	FAR END Alarm.....	4-15
4.7	ERRORS IN THE DATA STREAM.....	4-16
4.8	INTERFERENCE COUNTERMEASURES	4-17
4.8.1	Use of a Spectrum Analyzer to Evaluate Potential Interference.....	4-19
4.9	BACK-TO-BACK TESTING	4-20
4.10	LINK TESTING.....	4-22
5.	APPENDICES.....	5-1
APPENDIX A - DIGITAL INTERFACE SPECIFICATIONS	5-1	
1. General Characteristics.....	5-1	
2. Specifications.....	5-1	
APPENDIX B - REAR PANEL DIP SWITCHES	5-2	
APPENDIX C – NETWORKING Q&AS	5-8	
APPENDIX D - REAR PANEL DATA CONNECTORS	5-23	
APPENDIX E – INSTALLATION AND TROUBLESHOOTING GUIDE.....	5-25	

Figures

FIGURE 1-1: PROPER EARTHING/GROUNDING	1-4
FIGURE 2-1: FRONT PANEL, 2.4 & 5.8 GHZ w/o T/E1	2-13
FIGURE 2-2: FRONT PANEL, 2.4 & 5.8 GHZ w/ T/E1	2-13
FIGURE 2-3: REAR PANEL.....	2-18
FIGURE 3-1: CHANNEL PLAN, 2.4 GHZ (2 MBPS).....	3-12
FIGURE 3-2: CHANNEL PLAN, 5.8 GHZ (4 MBPS & 12 MBPS).....	3-12
FIGURE 3-3: CHANNEL PLAN, 5.8 GHZ (8 MBPS).....	3-13
FIGURE 3-4: CHANNEL PLAN, 2.4 GHZ (12 MBPS).....	3-13
FIGURE 3-5: NEGATIVE VOLTAGE DC CONNECTION	3-17
FIGURE 3-6: POSITIVE VOLTAGE DC CONNECTION	3-17
FIGURE 3-7: AC CONNECTION.....	3-18
FIGURE 3-8: TYPICAL RSL VOLTAGE VERSUS RECEIVED SIGNAL LEVEL (RSL).....	3-23
FIGURE 3-9: SPREADING CODE SELECTION.....	3-26
FIGURE 3-10: TYPICAL RF OUTPUT POWER VERSUS PWR VOLTAGE, 2.4 GHZ MODELS	3-29
FIGURE 3-11: TYPICAL RF OUTPUT POWER VERSUS PWR VOLTAGE, 5.8 GHZ MODELS	3-30
FIGURE 3-12: ERROR LED MODE SELECTION	3-37
FIGURE 3-13: RJ-11 ORDERWIRE TELEPHONE CONNECTION.....	3-39
FIGURE 3-14: VF PORT CONNECTION.....	3-40
FIGURE 3-15: PIN CONNECTIONS, ALARM INTERFACE	3-41
FIGURE 3-16: DIAGNOSTIC PORT PROTOCOL SELECTION.....	3-43
FIGURE 3-17: RS-232 DIAGNOSTIC PORT CONNECTIONS	3-44
FIGURE 3-18: RS-422 DIAGNOSTIC PORT CONNECTIONS	3-45
FIGURE 3-19: AUX DATA CABLE CONNECTION FOR REPEATER/HUB	3-46
FIGURE 4-1: BACK-TO-BACK TEST CONFIGURATION.....	4-21
FIGURE 4-2: END-TO-END TEST CONFIGURATION	4-22
FIGURE D-1: VF PORT CONNECTION.....	5-23
FIGURE D-2: ALARM PORT CONNECTIONS	5-23
FIGURE D-3: DIAGNOSTIC PORT 9-PIN D-STYLE CONNECTOR.....	5-24
FIGURE D-4: AUX DATA PORT 9-PIN D-STYLE CONNECTOR.....	5-24

Tables

TABLE 3-A: DC POWER CONNECTION FOR NEGATIVE SUPPLY	3-15
TABLE 3-B: DC POWER CONNECTION FOR POSITIVE SUPPLY.....	3-15
TABLE 3-C: TRANSMITTER OUTPUT POWER ADJUSTMENT, +6 dBW EIRP INSTALLATIONS	3-33
TABLE 3-D: TRANSMITTER OUTPUT POWER ADJUSTMENT FOR 2.4 GHZ, USA INSTALLATIONS	3-34
TABLE 3-E: ALARM INTERFACE CONNECTIONS.....	3-42
TABLE A-1: INTERCONNECTION SPECIFICATION.....	5-1
TABLE B-1: TSUNAMI 2.4 GHZ (~2 MBPS) SWITCH SETTINGS	5-3
TABLE B-2: TSUNAMI 5.8 GHZ (~ 4 MBPS) SWITCH SETTINGS	5-4
TABLE B-2: TSUNAMI 2.4/5.8 GHZ (~ 8/12 MBPS) SWITCH SETTINGS	5-6
TABLE B-3: TSUNAMI TBOS BIT MAP.....	5-7

1. How to Use This Manual

1.1 Manual Organization

The Installation and Maintenance Manual provides information required to install and maintain *Tsunami* and to use its many features to the fullest advantage. This manual is divided into the following sections:

- Section 1** *How to Use This Manual.* Provides instructions on how to most effectively utilize the information in this manual.
Earthing (Grounding) Considerations. Provides UL and other necessary regulatory warnings.
- Section 2** Provides a brief description and specifications of the *Tsunami*.
- Section 3** Explains the *Tsunami* installation and adjustments in detail.
- Section 4** Provides maintenance, repair and troubleshooting information for the *Tsunami Spread Spectrum radios*.
- Appendices** Charts and diagrams are provided for radio connections and DIP switch settings along with other general information.



This device must be professionally installed. Instructions on setting the transmitter RF output power are contained in Section 3 of this Manual.



This device is to be used exclusively for fixed point-to-point operation that employs directional antennas.

1.2 Icons

Throughout this manual, the following icons are used to highlight areas of special interest and importance.



Note



Practical Tip



Caution

1.3 IMPORTANT SAFETY INSTRUCTIONS

This product is intended to be installed, used and maintained by experienced telecommunications personnel only.

This product has been evaluated to the U.S. and Canadian (Bi-National) Standard for Safety of Information Technology Equipment, Including Electrical Business Equipment, CAN/CSA C22.2, No. 950-95 * UL 1950, Third Edition, including revisions through revision date March 1, 1998, which are based on the Fourth Amendment to IEC 950, Second Edition. In addition, this product was also evaluated to the applicable requirements in UL 1950, Annex NAE.

WARNING - This unit is intended for installation in a Restricted Access location in accordance with Articles 110-18, 110- 26, and 110-27 of the United States National Electric Code ANSI/NFPA 70.

This equipment should be installed in accordance with Article 810 of the United States National Electrical Code.

When installed, this equipment is intended to be connected to a Lightning/Surge Protection Device that meets all applicable national Safety requirements. **TO AVOID INJURY, RISK OF FIRE, AND DAMAGE, DO NOT CONNECT THIS PRODUCT DIRECTLY TO AN ANTENNA, AND ENSURE THAT PROPER LIGHTNING ISOLATION IS ALSO PROVIDED BETWEEN THIS UNIT AND OTHER EQUIPMENT.**

Equipment is to be used and powered by the type of power source indicated on the marking label only.

This product is intended to be connected to a ± 24 VDC OR ± 48 VDC power source which must be electrically isolated from any ac sources and reliably earthed. Only a DC power source that complies with the Safety Extra Low Voltage (SELV) requirements in the Standard for the Safety of Information Technology Equipment, Including Electrical Business Equipment, CAN/CSA C22.2, No. 950-95 * UL 1950, Third Edition, can be used with this product. A 15-Amp circuit breaker is required at the power source. In addition, an easily accessible disconnect device should be incorporated into the facility wiring. Always use copper conductors only for all power connections.

WARNING - This equipment is intended to be earthed. If you are not using the power supply provided by Western Multiplex, you will need to connect the earthing conductor of your power source to the earthing terminal located on the back of the unit; or, connect an earthing conductor between the unit's earthing terminal and your earthing point. See III. for instructions. For safe operation, always ensure that the unit is earthed properly as described in this manual and per Figure 1-1.

Do not connect or disconnect the power cable to the equipment when the other end of the cable is connected to the dc power supply.

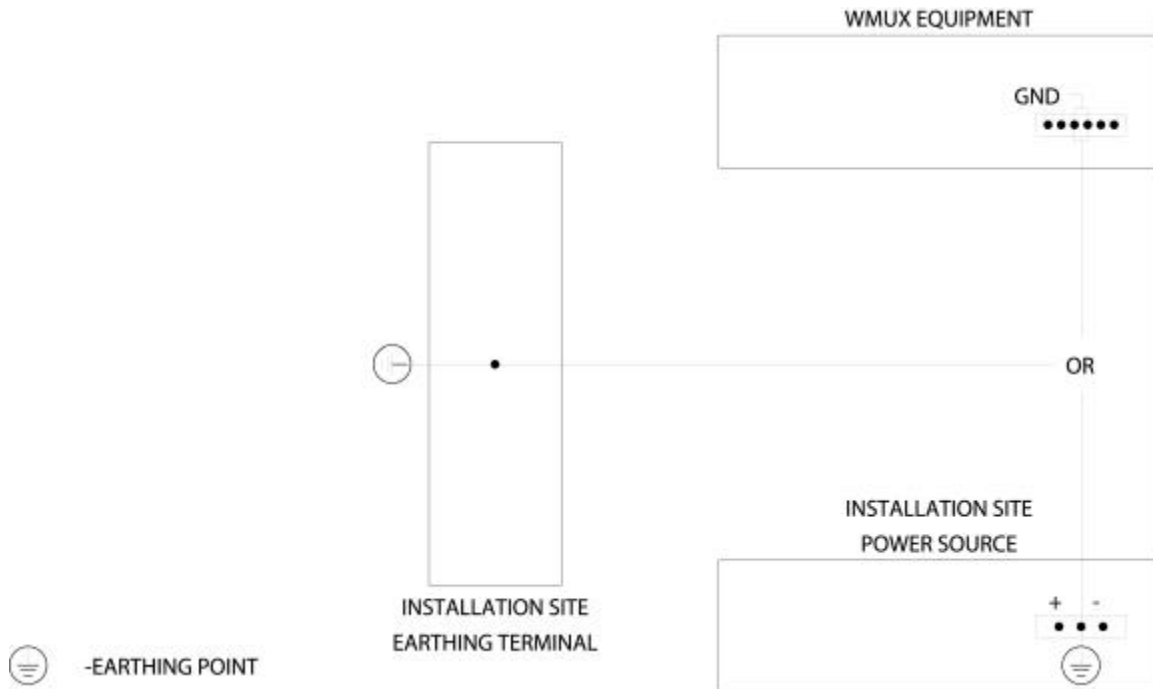

Figure 1-1: Proper Earthing/Grounding

Servicing of this product should be performed by trained personnel only. Do not disassemble this product. By opening or removing any covers you may expose yourself to hazardous energy parts. Incorrect re-assembly of this product can cause a malfunction, and/or electrical shock when the unit is subsequently used.

Do not insert any objects of any shape or size inside this product while powered. Objects may contact hazardous energy parts that could result in a risk of fire or personal injury.

Do not spill any liquids of any kind on or inside this product.

Side openings are provided for ventilation. To protect this product from overheating, do not cover or block any of the openings.

Always ensure that sufficient amount of space is provided above and below this product.

This product can be installed in a standard 19 inch rack. Check the size and clearance requirements for this product and ensure that enough clearance is provided for installation. Considerations should be given to the mechanical loading of the rack and the equipment to avoid potential hazards.

If this product is to be powered from the same source as other units, ensure that the power supply circuit does not get overloaded.

When installed in a rack, always ensure that proper air flow is provided for this product.

The maximum room ambient temperature (Tmra) for this product is 50°C. When installed in a closed or multi-unit rack, consideration should be given to installing this equipment in an environment compatible with the Tmra.

Equipment is suitable for mounting on concrete or other noncombustible surface only.

If you are using a handset not provided by Western Multiplex with this product, ensure that the handset is a UL-Listed (ITE) device, that has been evaluated to the Standard for the Safety of Information Technology Equipment, Including Electrical Business Equipment, CAN/CSA C22.2, No. 950-95 * UL 1950, Third Edition.

2. Product Description

2.1 General Description

The *Tsunami* Spread Spectrum radios provide a new level of control and convenience in a digital communications network.

The *Tsunami* radios provide 10BaseT intelligent bridging between two locations without the delay and expense of installing cable or traditional microwave.

Because each owner controls the operation of the link, there is no reliance on any outside services. *Tsunami* radio operators are able to operate instant links whenever needed, and to be in control of their own network.

The *Tsunami* offers two primary benefits:

- ❖ **CONVENIENCE** Easy to install and operate with **no user license requirements** or frequency coordination in the USA. (Other countries may require a user license and/or frequency coordination).

- ❖ **CAPABILITY** Full transparent Ethernet signals over any line-of-sight distance (typically up to 50 miles, depending on terrain and governmental regulations).



Tsunami radios are ISO Layer 2 Data Link Layer (use MAC address for filtering) devices where they provide their full stated throughput. At level 2 (bridges) or 3 (routers) where hardware plays the major part, the most common tester is the SmartBits 200 product from NetCom Systems. At Application Layer 7, you may see less than 60% throughput from the maximum capacity measured w/SmartBits due to the increased protocol/software overhead at that level. Layer 7 can be tested with software such as Ganymede's Chariot or Qcheck product (<http://www.qcheck.net/index.html>). Use Qcheck (or equivalent), do NOT use PING for throughput testing (<http://www.qcheck.net/whyqcheck.html>)!

As an example: testing copper CAT5 cable with SmartBits will test 100% throughput (let's say you can send/rcv a full 10Mbps). At Layer 7 you will be transferring data at the 10Mbps rate, but only 4-6 Mbps of user data will transfer (Ethernet has a high overhead of bytes added to each data packet each time you go up a layer). The advantage is the more complex overhead makes the data virtually resilient to corruption and minor errors (i.e. collisions), it's easy to reroute and can use inexpensive plug/play devices like hubs/switches instead of multiplexers as used in the telco industry (i.e. LYNX T1 radios)

Western Multiplex tests at Layer 2/3 where bridges are defined. At layer 7 (application layer), you will may less than 60% or more depending on the other traffic that may be on the LAN as this layer is more dependent on the type of data being sent (it does not matter if it's wire, fiber or any Ethernet bridge - wired or wireless). Another way to look at it: the model 31145 12Mbps (10Mbps 10BaseT+T1/E1 wayside) bridge will test the same as a piece of CAT5 Ethernet cable.

2.1.1 Response Time and Equipment

Also refer to Appendix E fold-out as an additional guide

Requirements for Full Duplex

For a network to support Full Duplex, both devices must support and be configured for Full Duplex. Full Duplex is intended to increase the speed of a direct link between two devices. i.e., between switches, or between an end-station and a switch. Switches support Full Duplex, hubs do not. Configuring an adapter for Full Duplex operation while connected to a hub or other half duplex device (NIC, etc.), can cause many network issues such as slowness, packet loss or station drop-offs.

What is Auto-Negotiation?

Auto-Negotiation is a protocol between devices where they negotiate highest common speed. Also known in the industry as NWAY. Since every frame is tested for speed and configuration, auto-negotiation takes away from the maximum bandwidth possible through a network. When possible, do not use auto-negotiation especially when the port configuration is known (e.g. 10 or 100Base, half or full duplex, etc.). Tsunami radios are especially sensitive and work best only with devices hard set to the radio's configuration (e.g. full duplex, 10BaseT) and NOT in auto-negotiation nor auto-sense.

What is the difference between 10 and 100BaseT (or F)?

These are fully different and mostly incompatible Ethernet communication. Ten (10)Base is any throughput speed from 1bps to 10Mbps, 100Base (also known as Fast Ethernet) is any throughput from 1bps to 100Mbps with the 10BaseT standard NOT capable of transmitting the full throughput of a 100Base device. Each has its own set of communication rules and need to be considered separately when communicating with either standard. Many hubs, switches and routers will auto-negotiate between these two speeds, but Tsunami radios (in order to maximize their throughput) do NOT auto-negotiate. Many throughput problems have been found when the computer's Ethernet NIC card is set to auto-negotiate when it should be set (through Network Properties) to NOT auto-negotiate. Although if the switch, router or NIC is set for auto-negotiation, the interface will function but the throughput speed can suffer considerably and high latency can result. All NICs & routers and most "managed" switches can be hard set or programmed to not auto-negotiate (both 10/100Base and full/half duplex) and is the desired set-up for maximum Ethernet throughput with any network especially those with wireless components.

Hub Vs Switch

All the devices connected to a hub are in the same collision domain. These devices share the bandwidth of the hub (10 Mbps for Ethernet or 100 Mbps for Fast Ethernet). By contrast, each port of a switch is actually the entrance to a separate collision domain with its own dedicated bandwidth. Each domain is either shared by other devices or dedicated to a single device. If many devices and the network is utilized over 25%, a switch is necessary to optimize Ethernet traffic. If economics allow, a programmable or managed switch is desirable for many reasons such as for the reasons above and that spanning tree can be easily accomplished if needed in a network.

Response time slower with switch than it was with a hub

Low volume on the network could cause a slowness in performance when a switch is introduced into an environment where a hub was used previously. There may not be enough traffic on the network to warrant a switch. When network utilization starts to reach 25 - 30%, the conditions are good for a switching product.

2.2 Specifications



All specifications are subject to change without notice.

2.2.1 Transmitter

<u>All Models</u>	
Frequency Selection	Rear Panel DIP switches; 7-cavity RF filter assembly
Modulation	OQPSK
Coding	Direct Sequence
Number of Codes	4 (Rear Panel DIP switch selectable)
<u>2.4 GHz</u>	
Output Power (typ.)	+27 dBm*
Output Power (max.)	+30 dBm*
Control Range	16 dB min.
Frequency Range	2410-2473 MHz (occupies 2400- 2483.5 MHz)
<u>5.8 GHz</u>	
Output Power (typ.)	+20 dBm
Output Power (max.)	+23 dBm
Control Range	20 dB min.
Frequency Range	5741-5834 MHz (occupies 5725- 5850 MHz)

* May be limited due to EIRP restrictions in a particular country

2.2.2 Antenna / Antenna Coupling Unit

<u>All Models</u>		
Mechanics	External antenna	
Antenna Connection	N-type female	
Impedance	50 ohms	
Recommended Antenna (not included)	<u>2.4 GHz</u>	<u>5.8 GHz</u>
	4, 6, or 8 foot parabolic	2, 4, 6, or 8 foot parabolic & flat panel
Gain & Beamwidth (3 dB)		
2 ft Antenna	N/A	29 dB / 6°
4 ft Antenna	27 dB / 7°	35 dB / 3°
6 ft Antenna	31 dB / 5°	38 dB / 2°
8 ft Antenna	33.5 dB / 3.5°	41 dB / 1.5°

2.2.3 Receiver

<u>All Models</u> (2 and 4 Mbps Models are discontinued)				
Nominal Receive Level	-30 to -60 dBm			
Maximum Receive Level	0 dBm error free, +10 dBm no damage			
Frequency Selection	Rear Panel DIP switches, 7-cavity RF filter assembly			
Processing Gain	10 dB minimum			
	<u>2.4 GHz</u> (~2 Mbps)	<u>2.4 GHz</u> (~8 Mbps)	<u>2.4 GHz</u> (~12 Mbps)	
Threshold Rx Level	-93 dBm	-88 dBm	-86 dBm (BER = 10 ⁻⁶)	
Frequency Range	2400 -	2400 -	2400 -	
	2483.5 MHz	2483.5 MHz	2483.5 MHz	
	<u>5.8 GHz</u> (~2 Mbps)	<u>5.8 GHz</u> (~4 Mbps)	<u>5.8GHz</u> (~8Mbps)	<u>5.8GHz</u> (~12Mbps)
Threshold Rx Level (BER = 10 ⁻⁶)	-92 dBm	-90 dBm	-88 dBm	-86 dBm
Frequency Range	5725 -	5725 -	5725 -	5725 -
	5850 MHz	5850 MHz	5850 MHz	5850 MHz

2.2.4 System (Single Hop Performance)

<u>All Models</u>				
Error Floor	10 ⁻¹¹			
Dispersive Fade Margin	58 dB, typical			
Transmission delay (radio only)	250 μsec, maximum			
(10 mile path)	300 μsec, maximum			
System Gain*	--USA-- <u>2.4 GHz**</u>	-----NO EIRP LIMIT ----- <u>2.4 GHz</u> <u>5.8 GHz</u>		
0.6m Antennas	N/A	N/A	158 dB	
1.2m Antennas	166 dB	169 dB	170 dB	
1.8m Antennas	174 dB	181 dB	182 dB	
2.4m Antennas	176 dB	181 dB	182 dB	
Typical Link Distance***	<u>0.6m Antennas</u>	<u>1.2m Antennas</u>	<u>1.8m Antennas</u>	<u>2.4m Antennas</u>
No EIRP Limit	≤24 km	≤64 km	≤80 km	>80 km
+6 dBW EIRP	≤8 km	≤16 km	≤24 km	≤32 km
<p>* Same size antenna and 30 meter 1/4inch coaxial transmission line (6.6 dB @ 5.8 GHz, 4 dB @ 2.4 GHz) at each end of the link with no EIRP limits.</p> <p>** (2.4 GHz EIRP limits apply in the U.S.A.)</p> <p>*** Assumes 30 meter 1/4inch coaxial transmission line and same size antennas at each end. Shorter and longer link distances can be accomplished depending on transmission line quality (and diameter), length of transmission line and other more minor factors.</p>				

System (Single Hop Performance)

Note: 2 and 4 Mbps models are no longer being manufactured

Transmit Frequencies			
	<u>2.4 GHz (~2 Mbps)</u>	<u>5.8 GHz (~2 Mbps)</u>	<u>5.8 GHz (~4 Mbps)</u>
A1 channel	2410 MHz	5735 MHz	5741 MHz
A2 channel	2453 MHz	5800 MHz	5803 MHz
B1 channel	2430 MHz	5755 MHz	5772 MHz
B2 channel	2473 MHz	5820 MHz	5834 MHz
C1 channel	N/A	5775 MHz	N/A
C2 channel	N/A	5840 MHz	N/A
Receive Frequencies			
	<u>2.4 GHz (~2 Mbps)</u>	<u>5.8 GHz (~2 Mbps)</u>	<u>5.8 GHz (~4 Mbps)</u>
A1 channel	2453 MHz	5800 MHz	5803 MHz
A2 channel	2410 MHz	5735 MHz	5741 MHz
B1 channel	2473 MHz	5820 MHz	5834 MHz
B2 channel	2430 MHz	5755 MHz	5772 MHz
C1 channel	N/A	5840 MHz	N/A
C2 channel	N/A	5775 MHz	N/A

System (Single Hop Performance) - continued

Transmit Frequencies				
	<u>2.4 GHz</u> (~8 Mbps)	<u>2.4 GHz</u> (~12 Mbps)	<u>5.8 GHz</u> (~8 Mbps)	<u>5.8 GHz</u> (~12 Mbps)
A1 channel	2408 MHz	2411 MHz	5735 MHz	5740 MHz
A2 channel	2449 MHz	2461 MHz	5800 MHz	5803 MHz
B1 channel	2426 MHz	N/A	5755 MHz	5772 MHz
B2 channel	2467 MHz	N/A	5820 MHz	5834 MHz
C1 channel	N/A	N/A	5775 MHz	N/A
C2 channel	N/A	N/A	5840 MHz	N/A
Receive Frequencies				
	<u>2.4 GHz</u> (~8 Mbps)	<u>2.4 GHz</u> (~12 Mbps)	<u>5.8 GHz</u> (~8 Mbps)	<u>5.8 GHz</u> (~12 Mbps)
A1 channel	2449 MHz	2461 MHz	5800 MHz	5803 MHz
A2 channel	2408 MHz	2411 MHz	5735 MHz	5741 MHz
B1 channel	2467 MHz	N/A	5820 MHz	5834 MHz
B2 channel	2426 MHz	N/A	5755 MHz	5772 MHz
C1 channel	N/A	N/A	5840 MHz	N/A
C2 channel	N/A	N/A	5775 MHz	N/A

2.2.5 Digital Line Interface

<u>All Models</u>	
Data Interface	10BaseT (fully compatible with IEEE 802.3u/Ethernet V.2)
Connector	RJ-45/48c Pins:1=Tx+, 2=Tx-, 3=Rx+ & 6=Rx-
Remote Loopback	Internally generated test signal for self-testing the radio link
Configuration	Half duplex or full duplex on the WAN interface
Filtering	15,000 frames per second theoretical, before forwarding
Buffer	256-frame
Frame Length	Total size cannot exceed 1518 bytes (including: VPN, VLAN frames)
	Note: VPN/VLAN tagging is NOT supported within the 10BaseT standard, but may be attempted via router and/or manageable switch with this product -Use the MTU command to limit the data portion of Ethernet frame to 1496 bytes-
LAN Table	10,000 MAC addresses
Self-learning	Automatic learning and aging (IEEE 802.1D)
<u>2.4 GHz</u>	
Digital Capacity	~8Mbps full or half duplex (16Mbps total) – “stealable” T1/E1 (future)
T1/E1	~12Mbps full or half duplex (24Mbps total) with wayside T1/E1 and a “stealable”
<u>5.8 GHz</u>	
Digital Capacity	~8Mbps full or half duplex (16Mbps total) – “stealable” T1/E1
	~12Mbps full or half duplex (24Mbps total) – with wayside T1/E1 + “stealable” T1/E1
<u>Models with wayside T1 or E1 line and/or “stealable” T1 or E1 interface</u>	
T1 or E1 capacity	T1 (1.544Mbps) or E1 (2.048Mbps)

2.2.5.1 T1 Interface Models

<u>T1 Models</u>	
Data Rate	1.544 Mbps
Digital Interface *	DSX-1
Connector	DB-9 female, 8-pin modular jack female (RJ-48C) Pins:1=TT, 2=TR, 4=RT & 5=RR
Line Code	AMI / B8ZS (rear panel DIP switch selectable)
Line Build Out	0-660 feet (rear panel DIP switch selectable)
Blue Code **	Alarm Indication Signal (AIS)
Remote Loopback	Internal or external test signal (rear panel DIP switch selectable)
* Meets AT&T Pub 62411, Bellcore TR-TSY-000499.	
** Signal is selectable (on/off) and is generated only on data loss or link failure when selected.	

2.2.5.2 E1 Interface Models

<u>E1 Models</u>	
Data Rate	2.048 Mbps
Digital Interface *	CEPT-1
Connector	RJ45/8 balanced, 120 ohm (optional 75 ohm unbalanced balun available) Pins:1=TT, 2=TR, 4=RT & 5=RR
Blue Code **	Alarm Indication Signal (AIS)
Remote Loopback	Internal or external test signal (rear panel DIP switch selectable)
• Meets ITU-T G.703	
** Signal is selectable (on/off) and is generated only on data loss or link failure when selected.	

2.2.6 Auxiliary Connections

<u>All Models</u>	
Orderwire Interface	2-wire, 4-pin modular jack, female (RJ-11)
REN (Ringer Equivalency Number)	1.0 B
DTMF tones	within $\pm 1.5\%$ of nominal freq. (+0-6 dB)
Ringing Voltage	48 VDC, typical
	<i>(use telephones with solid state ringers, NOT adequate for older style mechanical ringers)</i>
VF Orderwire Bridge	600 ohm balanced, 4-wire, 0 dBm, DB-25, male
Configuration Port (Config)	RS-232/ RS-422 (Craft), DB-9, male
Aux Data (clear service channel)	RS-232 / RS-422, ≤ 9600 baud, DB-9, female
Alarm	2 x Form C, 6xTTL signals on DB-25, female
Test Points	Output Power Near-end and far-end received signal level (RSL)

2.2.7 Temperature and Environment

<u>All Models</u>	
Operating Temperature Range	-30 to +50°C
Humidity	95% non-condensing
Altitude	4 500 meters maximum

2.2.8 Power

<u>All Models</u>	
DC Input Voltage	±20 to ±63 VDC
Power Consumption	< 45 watts
AC Adapter (optional)	100-250 VAC, 50-60 Hz
Connector	Barrier strip, plug in type

2.2.9 Regulatory Information

<u>2.4 GHz</u>	
FCC Identifier	HZB-LYNX42 or HZB-S24-12
FCC Rule Parts	15.247
Industry Canada ID	522 102 748A or 202 810 21852A
IC Rule Parts	RSS 210
ETSI	ETS 300-328 & -826
<u>5.8 GHz</u>	
FCC Identifiers	HZB-S24-02, HZB-S58-04, HZB-LYNX96, HZB-S24-12, HZB-S58-12
FCC Rule Parts	15.247
Industry Canada ID	522 102 767A, 522 102 1454A or 202 810 1684A
IC Rule Parts	RSS 210
* Approved and/or Certified in many other countries (consult factory)	

2.2.10 Mechanical

<u>All Models</u>	
Width (for 19-inch EIA rack mounting)	437 mm (17.2") rack mounting brackets supplied
Height	89 mm (3.5") (2RU)
Depth	368 mm (14.5")
Weight	5 kg. (11 lbs.)

2.3 Front Panel Description

2.3.1 General

The *Tsunami* radio front panels, as shown in Figure 2-1 through 2-2, have LED indicators, test points, controls and connections that are used for installation, maintenance, operation and troubleshooting. Prior to installation, it is best to be familiar with the front panel of your particular model. Sections 2.3.2 through 2.3.5 briefly describe the front panel access and lights from left to right.

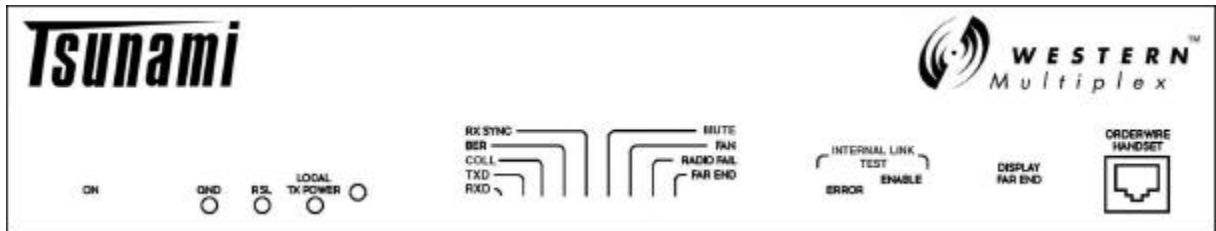

Figure 2-1: Front Panel, 2.4 & 5.8 GHz w/o T/E1

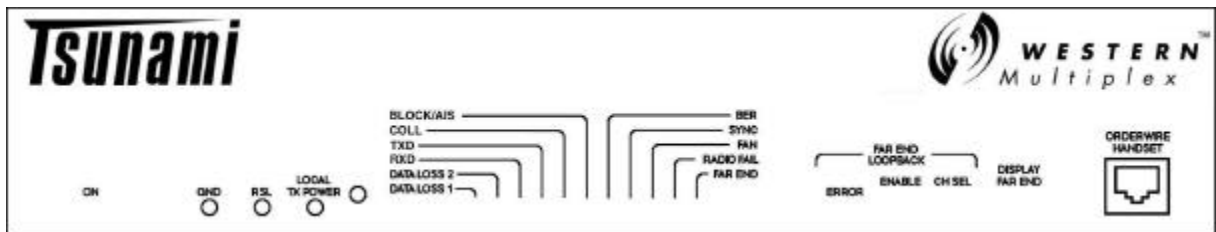

Figure 2-2: Front Panel, 2.4 & 5.8 GHz w/ T/E1

2.3.2 Test Points / Power Indicator

ON This is an LED indication. When lit GREEN, *Tsunami* is powered.



The Tsunami radio products do not have an on/off switch.

GND This is a test point referenced to chassis ground. This is used in conjunction with the next two test points to measure voltages related to radio performance.

RSL This is a test point which relates to the Received Signal Level (RSL). A voltage can be measured with a voltmeter (using the GND test point for reference) which corresponds to the actual power level of the incoming received signal. While the DISPLAY FAR END button is pressed, this RSL voltage corresponds to the RSL of the far-end radio. These measurements are used during installation, maintenance and troubleshooting.

LOCAL TX PWR This is a test point which corresponds to the output transmit power of the radio. A voltage can be measured with a voltmeter (using the GND test point for reference) which corresponds to the actual power level of the outgoing signal. This measurement is used during installation, maintenance and troubleshooting



This voltage only applies to the near-end and does not allow measurement of the far-end output transmit power, even when the DISPLAY FAR END button is pressed.

There is a receptacle on the front panel to the right of the LOCAL TX PWR test point which is an installation adjustment allowing the output transmit power to be increased or decreased within the radio's specified limits. Using a small screwdriver, this adjustment is used to set the output power of the transmitter, in accordance to the path planning.



The Tsunami system requires professional installation. Transmitted output power limits may apply when using this radio. Consult FCC, IC, ETSI, Western Multiplex or other regulatory authorities for limits which may apply. See Section 3.13.1 for details on setting output power.

2.3.3 Alarm and Status Indicators

- TXD** When lit GREEN, indicates transmitted data into the wireless link.
- RXD** When lit GREEN, indicates received data from the far end of the wireless link.
- COLL** This is an alarm. When lit RED, indicates that Ethernet collisions are occurring. These collisions may be normal for a heavily used WAN, but should be remedied as soon as possible as the maximum throughput of the radio link is not being realized. It is normal for the COLL indicator to blink occasionally.
- BER** This is the Bit Error Rate (BER) alarm. When lit RED, this alarm condition indicates that the received signal bit error rate is above the error threshold of 1×10^{-6} . This alarm condition typically indicates a path problem or a problem with the far-end radio and usually is not a problem with the near- end radio.
- SYNC** When lit RED, this is an alarm condition indicating that the intended received signal is not being received. This alarm may indicate problems related to the path, connections, or the near-end or far-end radio hardware.
- MUTE** When lit RED, this is an alarm condition indicates that one or both of the following:
1) The security address setting for switch 2 on the back of the radio does not match the radio bridge on the other end of the link.
2) There is an excessive number of data errors on the 10BaseT connection that the radio will not transmit so it MUTEs (or BLOCKS) the data from being sent.
- FAN** When lit RED, this is an alarm condition indicating a failure with one or both of the internal cooling fans. The radio is designed to operate within specification when only one fan is operating. The two fans are provided for redundancy only.
- RADIO FAIL** When lit RED, this is an alarm condition indicating a major failure with the near-end radio hardware.
- DATA LOSS** When lit RED, this is an alarm condition indicating that the T1 (or E1) interface is not receiving a proper signal on the corresponding input channel. This alarm can be disabled via the rear panel DIP switch settings so if the T1 (or E1) interface is not used, will not cause a nuisance alarm. If enabled and there is a loss of data, the local radio will inject AIS (Alarm Indication Signal) into the data stream to the far-end radio. This alarm is not present on the 2 or 4Mb Tsunami models.
- FAR END** When lit RED, this is an alarm condition indicating that there are alarm or status conditions present on the far-end radio. Press and hold the "Display Far End" button on the near-end radios to indicate the alarm conditions for the far-end radio terminal. Monitoring the far-end alarms can be helpful for radio installation and routine maintenance.

2.3.4 Controls



Link test transmits either an internal signal and re-transmits this signal back at the far-end radio. The near end then receives the signal. This is very useful for testing because the test signal can be monitored at the near-end and the quality of the entire link can be determined without anyone going to the far-end radio location.

ERROR When lit RED, this indicates that bit error(s) occurred while in link test mode.

ENABLE This is a push-button switch that executes the link test mode. Link test is initiated by pressing and holding this switch for approximately 3 seconds. Once in link test mode, the LED which is embedded in the switch is illuminated YELLOW to indicate that the test is in progress. The LED on the near-end radio flashes while the far-end is solid. Link test is disabled by pushing and releasing the ENABLE button at either the near-end or far-end radio. For radios with wayside(s) T1 or E1, the channel select switch is used to set which to perform the link/loop test. Three (3) blinks indicates bit error testing the Ethernet portion of the radio (internal only test source-Ethernet does not loopback). To select one of the wayside channels (if enabled), hold down the CH SEL switch for 3 seconds and release. One (1) or two (2) blinks indicate which T1/E1 data channel is being looped back (internal or external BER test source applies).



Enabling link test will interrupt traffic. This is an out-of-service test.

DISPLAY FAR END This push-button provides the capability to determine alarms and status of the far-end radio. When pressed and held, the alarm and status LEDs and the RSL test point correspond to the far-end radio's status and RSL value. This can be used for installation, maintenance and troubleshooting. When the LED on this switch is flashing, no far-end information is available. This typically indicates that there is no link between near-end and far-end radios.

2.3.5 Connections

ORDERWIRE

This connection is used to access the orderwire function. This is a facility for "telephone" style service from one radio to another. A standard electronic telephone [one with a handset and DTMF (push-button tone) dialing] plugs into this connector. The user can dial the orderwire address of the far-end radio (or any radio in the *Tsunami* network) to establish telephone communication between sites. This communication does not interrupt or interfere with the other radio communications. The radio link must be operational to use this facility. The orderwire feature can be very useful for installation, maintenance and troubleshooting.

- Touch-tone Telephone* (for communication with far-end)

*Telephone connection specifications:

REN (Ringer Equivalency Number)	1.0 B
DTMF tones	within $\pm 1.5\%$ of nominal freq.
Ringing Voltage	48 VDC, typical
<i>(Ringing voltage is adequate for modern solid state ringers, NOT for the older mechanical type ringers)</i>	

2.4 Rear Panel Description

The *Tsunami* radio rear panel, as shown in Figure 2-3, has connections and DIP switches that are used for installation, maintenance, operation and trouble-shooting. Prior to installation, you should familiarize yourself with the rear panel.

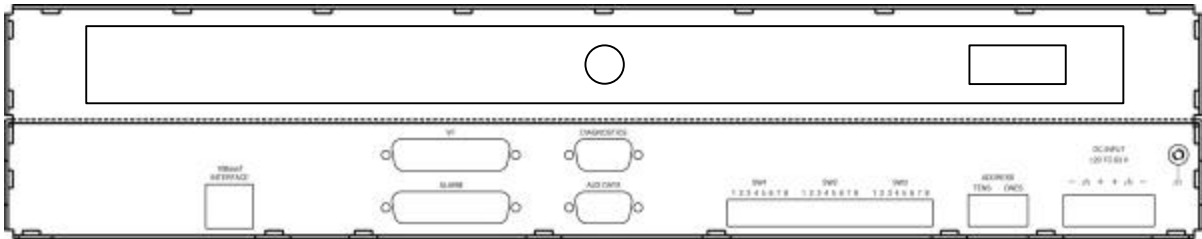

Figure 2-3: Rear Panel

2.4.1 RF Connection

The RF port of the *Tsunami* radio is an N-type female connector that is an integral part of the filter assembly. The filter assembly occupies nearly the entire top half of the rear panel. The N-Type connector is used to connect the antenna, typically using coaxial transmission line. In some cases, waveguide may be used as the primary transmission line, in which case a waveguide-to-N adapter is required.



For the Tsunami, 1/2" or 5/8" coaxial cable (LDF4-50 or LDF4.5-50) is recommended. Coaxial cable that is 7/8" or larger can exhibit moding at 5.8 GHz and is not recommended for 5.8 GHz radios. For waveguide transmission line at 5.8 GHz, EW-52 waveguide is recommended. EW-63 will also work, but may exhibit more loss.

2.4.2 DATA Connections

The connection for the Ethernet interface that carries the signals in and out of the radio is a RJ45 10BaseT connection.

2.4.3 Auxiliary Data Connections

There are 5 auxiliary data connections for *Tsunami* as shown in Figure 2-3.

VF This connector is used to link two *Tsunami* radios at a repeater site for Orderwire operation. This would allow orderwire "telephone" calls to and from any point in the *Tsunami* network.



The Tsunami orderwire circuit can also be connected to other existing orderwire networks. See Section 3.14.1 for details.

ALARM This connector is used for monitoring alarms electrically. The alarm connections are essentially the same as described for the front panel, however instead of LED operation, alarm status is provided electrically by means of TTL and Form C relay connections. The TTL and Form C relays can be connected to other transmission equipment for monitoring alarm status locally or remotely.

DIAG-NOSTICS This is a serial interface port (RS-232 or RS-422, ≤ 9600 baud) to the *Tsunami* radio. This port provides maintenance information about the *Tsunami* radio(s) to a connected computer or terminal. This port is typically used for maintenance and troubleshooting.

AUX DATA This is a serial interface port (RS-232 or RS-422, ≤ 9600 baud) which allows the user to connect auxiliary serial data from one point in the radio network to another. This facility can also be used for bridging the DIAGNOSTICS port for remote alarm and status monitoring or for connecting other equipment's serial alarm information. It can alternatively be used for separate data connection for serial devices.

2.4.4 Switches

There are three sets of 8-segment DIP switches (SW1, SW2 & SW3) and two rotary switches (Address TENS and ONES), as shown in Figure 2-3 on the rear panel of the *Tsunami* radio. These switches provide user configuration of several radio parameters. A brief explanation for each function follows.



Refer to the switch setting detail in Appendix B.

SW1

Full or Half Duplex

Choose whether the bridge is to use the half duplex (normal-down position) or the full duplex mode. Half duplex uses the maximum bit rate in one direction while full duplex allows the maximum bit rate to be used in both directions simultaneously effectively doubling the maximum throughput if the LAN on each end of the link can transmit and receive at the same time if the network devices at each end of the bridge can and are set up to utilize the full duplex capability.

Filtering Enable/ Disable

OFF or down position (normal) allows only frames destined for another LAN to be transmitted over the WAN. ON or up switch setting sends all frames over the WAN. Disable filtering for LAN extender or segmenter applications.

TBOS or Data

Select whether the auxiliary data port is to be used with OpenLYNX™ (TBOS interface) or by the user as a dedicated data port. OpenLYNX is the default (down) setting.

Error Unlatch

This switch segment selects an optional mode for the ERROR LED to flash for each error occurrence (instead of latching on). This can be useful for short duration link testing when the operator is located at the terminal site and watching for errors.

Data Mute/AIS Disable

This switch, when set in the ON/up position, will disable the automatic MUTE/AIS function of the bridge radio. The radio may also MUTE the link's communication if the security addresses of the link are not the same (see switch 2). Refer to section 2.3.3 for a description of the MUTE function and front panel light for further detail.

Enable Aux Data

This switch segment allows the AUX DATA port to be optionally used as a clear service channel for RS-232 or RS-444 (≤ 9600 baud) user data. The radio normally uses this port for TBOS radio diagnostics. Set the switch to the ON or up position to use this port for your own data use.

SW2

Ethernet Bridge Address

These switch segments allow the user to select a unique address for a particular link between two LANs. This feature provides a level of security to prevent another radio in the communication path to pick up the transmitted data unless it is set to the exact same address (1 out of 256 unique addresses). Be sure each point-to-point link is set to the same address. If not, the radio will invoke the MUTE function. *Do NOT use the factory default of all zeros!*

SW3

Spreading Code

This set of switch segments allow the user to select the spreading code for the spread spectrum signal. Both ends of a radio system must be set to the same code. Users may wish to change codes for radios that are nearby other similar radios to aid in interference rejection. (see Section 3.12.3)

Line Build- Out and T1/E1 Channel Disable

Line build out (T1 only) allows for extended T1 connection cables.

Channel 1 and/or 2 Disable provides for unused wayside channels to be disabled so that they do not cause unnecessary alarm(s) to be generated or displayed on the radio's front panel.

Frequency Selection

This set of switch segments programs the radio to match the specific RF channel corresponding to the RF filter set which has been installed. (see Section 3.12.1)

Rotary SW

Address

There are two rotary switches which determine the radio's address (01 to 99). This address is used for Orderwire signaling (dial a particular radio in the network).



Refer to Appendix B for Switch Settings

2.5 Installation Accessories

The *Tsunami* radio is shipped with several accessories commonly required for the radio as described below:

AC Power Supply If ordered as an option, this power supply provides AC to DC conversion for use with AC powered locations.

AC Power Cord This power cord connects the AC Power Supply, if ordered, to a standard 115V U.S. AC outlet.

Rack Mount Brackets Two brackets (along with required mounting screws) are provided which allow 19-inch rack mounting of the *Tsunami* radio.

Terminal Connector This is a 6-pin mating connector used for DC power supply.

D Connector 9-pin Two of these mating connectors are provided. One is used for the DIAGNOSTICS port interface and another for the AUX DATA port.

D Connector 25-pin There are 2 mating connectors provided, one for the ALARM interface and the other for the VF interface.

RF Power Adjustment Cover A small plastic cap is provided which is placed over the RF output power adjustment receptacle once output power has been set by professional installation personnel.

Other accessories are available, such as orderwire handsets, connector adapters and special cables. These can be ordered separately upon request.



Your Notes on the *Tsunami* Radio

3. Installation & Adjustments

3.1 Shipping Container

The equipment is shipped in boxes unless ordered as an integrated system and configured at the factory, in which case the equipment may be racked and shipped in a crate. The equipment is packaged so as to prevent damage in transit.

The boxes should be left intact and sheltered until arrival at the installation site.



If the shipping container shows signs of damage, the transportation company should be notified immediately. Extra care and inspection of the contents is advised immediately upon receipt.



It is recommended that all the packaging materials be retained. In the unlikely event that the equipment must be returned to the factory, use the original packing materials for return shipment. ***The original packaging materials are also recommended for transporting the equipment from location to location.***

Inside the primary shipping containers, internal boxes may contain other items. These boxes should also be saved for future use.



Also, save the Tsunami radio test data sheet that is provided. The test data sheet can be placed where the Tsunami terminal will be installed for future quick reference. This sheet could also be placed in the front pocket of this manual, and the manual kept at the radio location for future reference. All Tsunami units are individually tested and the actual measured performance recorded on the Factory Test Data Sheet. You will find this information to be of use during installation, troubleshooting and maintenance.

A set of quick installation instructions is also provided which can be useful for easy reference during installation.

3.2 Packing Items Identification

The primary shipping container houses the radio and an additional box. The box contains several related items inside including:

- ❖ This manual
- ❖ Installation accessory kit (see Section 2.5)

3.3 Before Installation Task List

There are several tasks that should be accomplished prior to installing the *Tsunami* radio system. This section briefly describes the following:

- Site selection
- Line-of-Sight and Path Clearance determination
- Anticipated RSL calculation
- Fade margin calculation
- Availability calculation
- Frequency plan determination
- Power supply planning
- Antenna (and accessories) purchase



Only directional antennas should be used with Tsunami spread spectrum radios. These can be grid or solid parabolic antennas (minimum 2 foot - .6 meter). Flat panel antennas are also acceptable if the beam width is kept to a minimum.

3.3.1 Site Selection Requirements

The radio site must have:

- access to the appropriate power
- close proximity to the telephone or computer system you wish to interconnect
- line-of-sight to the other radio location with adequate clearance
- location for mounting the antenna

3.3.2 Line-of-Sight and Path Clearance Guidelines

The *Tsunami* radios will not operate properly unless they have line-of-sight between their corresponding antennas. The *Tsunami* radio transmission will not pass through trees or other obstacles. Factors to consider include:

- Earth curvature
- Future growth of trees
- Height of buildings

In addition to the line-of-sight requirement, a well-engineered path will also have additional path clearance to allow for signal loss due to partial obstructions, atmospheric ducting and ground reflections. To maximize radio reception, 0.6 times the first Fresnel zone should be calculated and this distance added to the path clearance (in addition to trees or buildings).

3.3.3 RSL Calculation and Link Budget

The received signal level (RSL) can be estimated using the following formula:

$$\text{RSL (dBm)} = P_{\text{out}} - FL_1 + G_1 + G_2 - FL_2 - L_p$$

where: P_{out} is the transmitter output power (in dBm)

FL_1 is the feeder loss of the transmit side (in dB)

G_1 is the gain of the transmit antenna (in dB)

G_2 is the gain of the receive antenna (in dB)

FL_2 is the feeder loss of the receive side (in dB)

L_p is the Path loss, defined by:

$$L_p \text{ (dB)} = 96.6 + 20 \log_{10} F + 20 \log_{10} D$$

where: F = Frequency in GHz (2.4 or 5.8)

D = Distance of path in miles

This link budget is very important for determining any potential problems during installation. If you have calculated the expected RSL, you can see if it has been achieved during installation, and troubleshoot if necessary.



In the USA, 5.8 GHz models of the Tsunami may be installed with any size directional antennas and operated at full power. The 2.4 GHz model may require power reduction where: $P_{\text{out}} - FL_1 + G_1$ is replaced by $30 - [(G_1 - 6) / 3] + FL_1$



In some countries effective isotropic radiated power (EIRP) limits apply, such as +6 dBW (+36 dBm) in Canada. Output power may need to be reduced, and the above path planning equation changed such that: $EIRP \text{ (dBm)} = P_{\text{out}} + G_1 - FL_1$

3.3.4 Fade Margin Calculation

The fade margin is the difference between the actual received signal and the radio's threshold. Using the formula provided in Section 3.3.3, the anticipated RSL can be calculated. Compare this RSL to the specified threshold of the *Tsunami* radio, which is shown in Section 2.2, and calculate the fade margin as the difference between the two signal levels.

Dispersive fade margin is another factor that many microwave path engineers may use to plan their link budget. For the *Tsunami* radio, the dispersive fade margin is in excess of 55 dB and therefore is not a determining factor in path planning. This excellent dispersive fade margin performance is important because the spread spectrum RF signal has considerably wide bandwidth.

3.3.5 Availability Calculation

Availability of the microwave path is a measure of the percent of the time that the link will operate without producing an excessive BER due to multipath fading. In the absence of direct interference, availability is affected by the following:

- Path length
- Fade margin
- Frequency (2.4 GHz or 5.8 GHz in the case of the *Tsunami* radios)
- Terrain (smooth, average, mountainous)
- Climate (dry, temperate, hot/humid)

Depending on the type of traffic carried over the link, the system designer may wish to design for a specific availability. For example, if the data or voice traffic that is carried by the radio is critical then it may be designed for a very high availability (e.g. 99.999% or 5.3 minutes of outage per year). To improve availability, for example, the fade margin can be increased by making the path shorter, or by using higher gain antennas in conjunction with lower loss feeders (by using high quality transmission line or shortening feed length).

3.3.6 Frequency Plan Determination

When configuring radios in a hub or repeater configuration, careful engineering of the *Tsunami* radio frequency plans and antenna locations should be performed in order to minimize potential interference between the nearby radios. As a rule of thumb, do not place identical frequency plan radios (e.g. two "A" channel radios) at the same site. In most cases, it is desirable to use a different frequency plan (e.g. A versus B). However, with careful engineering, placing more than one radio of the same frequency channel plan at the same site can be accomplished. In fact, the *Tsunami* frequency plan is designed to allow complex hub configurations that may require re-using the same frequency plan. When designing these types of configurations, antenna size and antenna location are critical. If identical channel plans must be used at the same site, the same radio channel (e.g. A1 and A1) should be used at a site to minimize interference. Using alternate channels (e.g. A1 and A2) is less likely to be successful (and therefore not recommended) due to the high level of transmitter to receiver isolation required from the antenna system.

Sometimes it is required to locate the *Tsunami* radio nearby a transmitter that is the same as, or close to the *Tsunami* receive or transmit frequencies. In this case, the *Tsunami* terminal that should be placed closest to this interfering transmitter should be the specific terminal with the receive frequency which is furthest from this unwanted transmitted frequency. This approach minimizes the potential of interference. While interference conditions are rare when using the *Tsunami* radios, cases of interference may be overcome by exchanging the radios from end to end or simply reinstalling the filter unit, as described in Section 4.2 (thus swapping the frequencies of both ends of the radio link). In some cases, changing frequency plans (e.g. from A to B) can also help mitigate any interference.



Section 4.8 of this manual describes interference countermeasures in further detail.

3.3.7 Power Supply Planning

The *Tsunami* radio must have access to a supply of appropriate power, either DC or AC (if the AC adapter option has been ordered). The *Tsunami* can be powered from a DC battery system, or from a solar or generator power plant, usually with battery reserves. Typically either a positive or negative ground 24 or 48 volt supply is used. For DC, be sure the cable is of sufficient gauge to carry the necessary current and it is less than three (3) meters (9.75 feet) in length.

Before installing the radio, plan for the continuous power consumption needs in accordance with the specifications given in Section 2.2 of this manual. It is also wise to plan for backup power for critical communication circuits (including the *Tsunami* radio). Backup power allows the radios and associated equipment to continue operation when primary power is interrupted.

3.3.8 Antenna Planning

Using the path planning tools, proper antenna size can be determined which will yield the desired path performance. In general, the larger the antenna that is used with the *Tsunami* radio, the better the link will perform. Larger antennas have narrower beamwidth and higher gain, which will yield better link performance (higher fade margin, better availability) and improve immunity to interference (due to the smaller beamwidths). However, larger antennas are more costly to purchase and install than smaller antennas, in some cases requiring special equipment for installation. All of these factors should be taken into consideration when selecting antennas.



In areas where transmitted output power restrictions apply, the use of larger antennas will maintain the benefit of narrow beamwidths and receive gain. However, output power may need to be reduced to meet regulations. (See Section 3.13.1)

Prior to installation, the specific antenna location and mounting should be determined. This advanced planning also yields the transmission line requirements.



*Only directional antennas should be used with *Tsunami* spread spectrum radios. These can be grid or solid parabolic antennas (minimum 2 foot - .6 meter). Flat panel antennas are also acceptable if the beam width is kept to a minimum.*

3.4 Tools Required

The following tools may be required for the installation of the *Tsunami* radios:

- Phillips (cross tip) screwdrivers (for 19-inch rack mounting and attachment of brackets)
- Small blade standard screwdriver (for power supply connector and RF output power adjust)
- Soldering iron (if using any D-type connectors)
- Wire strippers (for removing insulation from power supply and other wiring)
- Digital Voltmeter (to measure RSL, Tx output power, Alarms)

The following tools are recommended for the installation of the *Tsunami* radios:

- RF power meter (to measure transmitter output power)
- Cellular phone or two-way radio (for talking with far-end crew and tower crew)
- Bit Error Rate test set (to test link after installation)
- Touch-tone Telephone* (to test orderwire circuits and for communication with far-end)

Additional tools will likely be needed for antenna and transmission line installation and antenna alignment. Consult Sections 3.8 through 3.10 of this manual for more details.

*Telephone connection specifications:

REN (Ringer Equivalency Number)	1.0 B
DTMF tones	within $\pm 1.5\%$ of nominal freq.
Ringing Voltage	48 VDC, typical
<i>(Ringing voltage is adequate for modern solid state ringers, NOT for the older mechanical type ringers)</i>	

3.5 Frequency Channel Plans

The *Tsunami* system offers several non-overlapping channel plans for the different models of radio. This channel plan arrangement allows users to implement *Tsunami* systems in the proximity of other *Tsunami* radios (planned or unplanned), hub and repeater applications, and can be used to mitigate interference. The channel plans are illustrated below in Figures 3-1 through 3-2. Section 4.2 and 4.3 describe how to change frequency channel assignments of a *Tsunami* radio.

Figure 3-1: Channel Plan, 2.4 GHz (2 Mbps is discontinued)

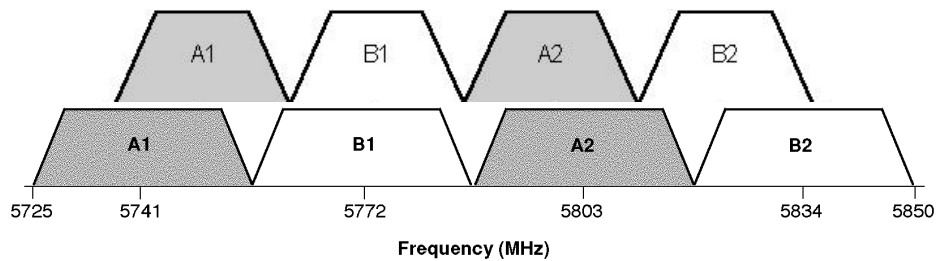

Channel Pairs			
<u>A1</u>		<u>A2</u>	
Tx 5741	→	Rx 5741	
Rx 5803	←	Tx 5803	
<u>B1</u>		<u>B2</u>	
Tx 5772	→	Rx 5772	
Rx 5834	←	Tx 5834	

Figure 3-2: Channel Plan, 5.8 GHz (4 Mbps & 12 Mbps)

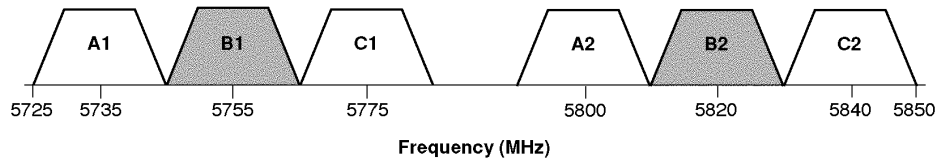

Channel Pairs				
<u>A1</u>			<u>A2</u>	
Tx	5735	→	Rx	5735
Rx	5800	←	Tx	5800
<u>B1</u>			<u>B2</u>	
Tx	5755	→	Rx	5755
Rx	5820	←	Tx	5820
<u>C1</u>			<u>C2</u>	
Tx	5775	→	Rx	5775
Rx	5840	←	Tx	5840

Figure 3-3: Channel Plan, 5.8 GHz (8 Mbps)

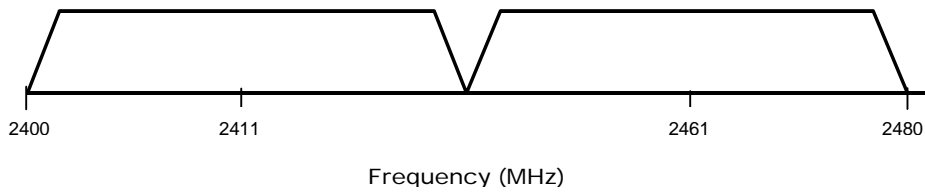

Channel Pairs				
<u>A1</u>		→	<u>A2</u>	
Tx	2411	←	Rx	2461
Rx	2461	→	Tx	2411

Figure 3-4: Channel Plan, 2.4 GHz (12 Mbps)

3.6 Mounting the *Tsunami*

The *Tsunami* radio can be mounted at any height in a standard 19-inch rack. Blank rack-mounting spaces above and below the *Tsunami* are recommended, especially if the surrounding equipment dissipates a considerable amount of heat (over 40W).

The *Tsunami* radio may be set up for mounting with the front edge projecting from the front face of a standard 19-inch rack using the rack mounting brackets enclosed with the screws in the Accessory Kit (4 per bracket). The rack mounting brackets may be reversed, in order to install for flush or cabinet mounting if preferred. Depending on rack configuration, it may be necessary to remove the four adhesive backed rubber feet on the bottom of the unit.



The *Tsunami* radio has internal fans which intake and exhaust on the left and right sides of the chassis. When rack mounting, it is important to leave a small gap between the outer edges of the radio and the inside edge of the rack.



The *Tsunami* radio may alternatively be placed on a table or shelf attached to a wall. Because of the low weight of the *Tsunami*, any mounting option other than rack mounting will be less secure.

3.7 Power Connection and Wiring



There is no ON/OFF switch on the Tsunami. As soon as power is applied, the equipment will be operational. This means that there can be up to 1W of RF power present at the antenna port. The antenna port should be terminated before power is applied.

Power is connected using the DC power plug contained in the Accessory Kit. Use Table 3-A or 3-B along with the associated diagram of Figure 3-7 or 3-8 to connect the DC power cables. For example, for a negative DC power input, use Table 3-A and Figure 3-7.

NEGATIVE DC POWER INPUT (-20 TO -63 VDC)	
PIN	FUNCTION
1	Power (-DC)
2	Ground (see figure 3-7)
3	Return (+DC)
4	Return (+DC)
5	Ground (see figure 3-7)
6	Power (-DC)

Table 3-A: DC Power Connection for Negative Supply

POSITIVE DC POWER INPUT (+20 TO +63 VDC)	
PIN	FUNCTION
1	Return (-DC)
2	Ground (see figure 3-8)
3	Power (+DC)
4	Power (+DC)
5	Ground (see figure 3-8)
6	Return (-DC)

Table 3-B: DC Power Connection for Positive Supply



Pins 1 and 6 are connected together on the motherboard. Either pin may be used to apply (-DC) DC power input. Similarly, pins 3 and 4 are connected together on the motherboard and may be used to apply (+DC) DC power input.



For DC power return connection, connect to the opposite voltage (either the -DC or the +DC Pin) and connect the return to ground at the DC power plug on pins 2 and/or 5.

3.7.1 DC Power Wiring

Connect the power cable with adequate current rating (minimum of 20 AWG) to the terminals shown on the removed (not plugged into the radio) DC power plug using the screw connections. The recommended minimum current rating of external fuses and cables is 3 Amps. The *Tsunami* radios consume less than 1 Amp at $\pm 48V$ and less than 2 Amps at $\pm 24V$. Be sure the DC power cable is less than 3 meters (9.75 feet) in length.



Each Tsunami terminal should be externally fused separately with a 5 Amp maximum fuse. The DC power cable must be less than three (3) meters in length.

If using **negative** power, connect the negative voltage to pins 1 or 6. Connect the ground return connection to pins 3 or 4. See Figure 3-5.

If using **positive** power, connect the positive voltage to pins 3 or 4. Connect the ground return connection to pins 1 or 6. See Figure 3-6.

The **ground** connection is available at pins 2 and 5. Either pin may be used to ground the return side of the power supply. Do not ground both sides of the power supply.



Proper grounding, either through the chassis and/or the power supply, can be very important for protection from lightning. A grounding screw hole is provided on the rear panel.



The ground connection may be left floating if the power supply is referenced to ground externally and to avoid ground loops in some configurations. However, this may not provide adequate grounding for lightning protection.

Use a DVM (digital voltmeter) to verify voltage and polarity on the DC power plug.



Do not connect the DC power plug to the rear of the Tsunami terminal until a load is connected to the antenna port (either an RF pad, or an RF cable and antenna).

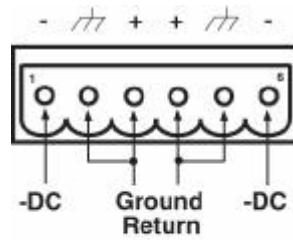

Figure 3-5 Connection

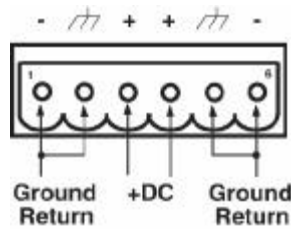

Figure 3-6: Positive Voltage DC Connection



Make sure that when connecting the mating plug that it is properly oriented (terminal screws pointing up) and securely fastened.

3.7.2 AC Power Connection

The optional AC power supply operates from any AC voltage 100V - 250V and 50 Hz or 60 Hz. The AC supply is equipped with a mating connector that plugs directly into the *Tsunami* radio and an AC cord with a 3-pin AC plug.

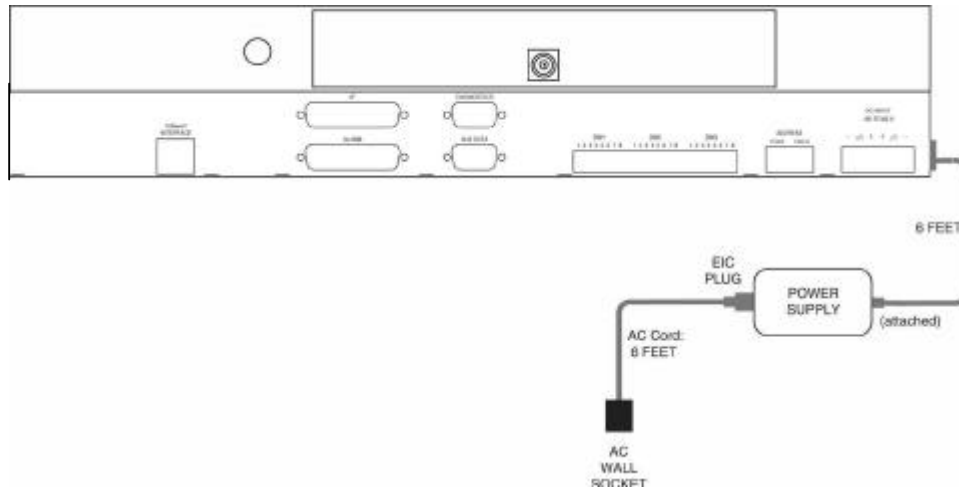

Figure 3-7: AC Connection

3.8 Antenna Connection

The *Tsunami* radio is equipped with an N-type female connector at the antenna port located on the rear panel. A short length (~6 feet) jumper cable such as RG-214 coax (or “pigtail”) fitted with two N-type male connectors can be used to connect the antenna port to the antenna transmission line (see Section 3.9). The recommended cable type for a jumper is RG-214.

A low loss 50-ohm cable (for example LDF4-50 1/2 inch coax) or EW-52 waveguide (for 5.8 GHz radios) is recommended for the antenna transmission line between the top of the rack and the antenna. The return loss presented by the transmission line at the top of the rack should be as high as possible (20 dB, minimum recommended). The length of the antenna transmission line should be kept as short as possible (to minimize losses).

For 5.8 GHz radios, to minimize feeder losses, the use of 5.8 GHz elliptical waveguide is recommended (typical loss is 1.25 dB/100 ft) for feeder lengths in excess of 200 feet. Depending on path length and feeder length, 1/2 inch coax cable can be used with 5.8 GHz radios.



For the Tsunami radio, 1/2” or 5/8” coaxial cable (LDF4-50 or LDF4.5-50) is recommended. Coaxial cable 7/8” or larger can exhibit moding at 5.8 GHz and is not recommended for 5.8 GHz radios. For waveguide transmission line at 5.8 GHz, EW-52 waveguide is recommended. EW-63 will also work, but may exhibit more loss.



Do not use right angle N-type connectors with the 5.8 GHz Tsunami radios: they may present high loss at 5.8 GHz. Do not use a low quality N-type jumper cable with the Tsunami. Some cable types, such as RG-8, may have high loss at 5.8 GHz.

3.9 Transmission Line Connection

The transmission line feeder (such as LDF4-50 1/2 inch coax cable or EW-52 elliptical waveguide) should be prepared first by cutting to the approximate length (allowing some excess) and installing the appropriate connector on the antenna end.

The prepared transmission line is then pulled through the cable ducts, trays or conduit (as required) to the antenna, while being careful not to kink or damage the transmission line in any way.

The transmission line should be supported in a tray on horizontal runs and by hangers on vertical runs. Hangers should be spaced according to the manufacturer's instructions (typically every 5 feet under conditions of no ice and not greater than 85 mph winds).

The transmission line should be grounded using the manufacture's recommended grounding kit. Grounding kits attach to the outer copper conductor. Grounds must be installed at the antenna, at the bottom of the tower (if applicable) and where the transmission line enters the building. Long transmission line runs should be grounded every 100 feet. In areas of high incidence of lightning, dissipaters should be attached to antennas. In addition, coaxial, in-line, spark-gap type, lightning suppressors should be added at the bottom of the coax cable before entering the building/enclosure.



Any in-line lightning protection device must be rated for the operating frequency of the Tsunami (2.4 or 5.8 GHz).

After installation, the transmission line is terminated with an N-type male connector/adaptor attached at the equipment end. For waveguide, this typically requires a CPR-to-N adapter.

Prior to operation, the electrical integrity of the transmission line, including all connectors, can be checked with a simple DC check between the center conductor and outer conductor. (This is neither possible, nor required for waveguide).

The transmission line should ideally be connected directly to the antenna at one end and to the Tsunami antenna port at the other end. However, short RG-214 type pigtail jumper cables may be required to avoid sharp bends in the transmission line to limit stress on either connection.



7/8 inch coax cable or larger is not recommended for use at 5.8 GHz and higher frequencies.



Do not use right angle N-type connectors with the 5.8 GHz Tsunami radios: they may present high loss at 5.8 GHz. Do not use a low quality N-type jumper cable with the Tsunami. Some cable types, such as RG-8, may have too high a loss at 5.8 GHz.

3.10 Antenna Installation & Alignment



INSTALLER CAUTION: Antennas used for this device must be fix-mounted on permanent outdoor structures to provide 5 meters or more separation from all persons during device operation to comply with FCC RF Exposure requirements. Installers should contact the manufacturer for applicable antenna gain and type restrictions to ensure compliance.

The antenna installation consists of mounting the antenna on the tower, building roof, or other location that provides line-of-sight path clearance to the far-end location. In general, antennas smaller than 2 feet diameter are not recommended for urban areas due to their wider beamwidths, which results in higher interference susceptibility. For 2.4 GHz *Tsunami* radios, a minimum of 4 foot (1.2m) diameter antennas, or larger, are recommended.

Antennas should be ordered with a suitable mounting kit specific to the site requirements. For example, specifying round or angle tower leg adapters, or a roof tripod as necessary.

The antenna must be very rigidly mounted, with adequate room for azimuth and elevation adjustment.

The antenna polarization must be the same at both ends of the link, either vertical or horizontal.

In general, antenna mountings require a support pipe to which upper and lower support brackets are attached with "U" bolts. The antenna and optional elevation and azimuth adjustment rods are then mounted onto the support brackets. The whole structure must be adequately grounded for lightning protection. The antenna system must always be installed according to the manufacturer's instructions.

Unless special test equipment is available, two operating *Tsunami* terminals are required to align the antennas. Alternatively, a CW generator may be used to transmit a signal toward the end under alignment.

The antenna is coarse aligned using visual sighting and then fine aligned using the receive signal level (RSL) voltage of the *Tsunami*.



The RSL voltage reading can still be used to peak antennas even if the radios have not synchronized, however far-end RSL cannot be measured from the near-end terminal until radios are synchronized.

To coarse align the antenna, first set it for flat elevation (no up or down tilt) using a spirit level. Then point it at a heading marker obtained using a compass back-bearing from an adjacent location, (ideally, 100 feet or more away from the antenna).

If a heading marker cannot be set sufficiently far away (for example when on a city building roof or looking through a window) then a rough azimuth setting can be obtained by sighting along the antenna feed.



It should be verified that both antennas are on the same polarization by using the manufacturer's instructions. Otherwise the RSL will be approximately 25 to 30 dB below the calculated level.

Most antennas will also need fine alignment obtained using an operating link because it is very important to maximize the receive RF signal level at each end of the radio link.



Read Section 3.7 before applying DC power to the Tsunami radio.

Once the coarse alignment has been set-up at both ends, then the link can be powered and some level of reliable communication established. The voltage at the *Tsunami* front panel RSL test point should be measured with a DVM to determine the relative receive RF signal level.

For the fine alignment, adjusting first the azimuth and then the elevation of the local antenna will maximize the RSL voltage. Then, the far antenna is aligned in the same way, using the RSL voltage of its local *Tsunami* radio.

When aligning antennas it may be convenient to run two wires from the RSL and ground test points to the antenna so that the voltmeter reading is directly visible to the technicians aligning the antenna. Also, a cellular telephone or two-way radio may be useful for coordinating alignment activities between both ends of the link. Once the radios are coarse aligned and synchronized, the built-in orderwire phone service can also be used to coordinate alignment between both ends of the link.



An orderwire telephone will provide end-to-end voice communications once radios are synchronized. Synchronization usually can be accomplished by coarse alignment only. After synchronization, the orderwire phones can be used to communicate between radio sites for antenna fine alignment. The phone interconnect cable can be extended to the antenna when desired.

The larger the antenna size, the more critical alignment becomes: for example, with a 2 foot dish, the antenna can be moved ± 3 degrees off the correct heading before the receive signal level drops by 3 dB. This compares with a 6-foot dish which may only be moved ± 1 degree for the same degradation.

The graph shown in Figure 3-10 shows the typical variation of RSL voltage as the receive signal level is increased from threshold to a higher level. There is some variation between *Tsunami* receivers, but an approximate estimate of the potential RSL value may be made using this figure.



Use the Factory Test Data Sheet shipped with your Tsunami terminal to obtain the best estimate of your RSL.

Above 0 dBm RSL, the receiver may produce errors: however this level is rarely likely to be exceeded. A link budget calculation should be made to calculate the anticipated RSL as described

in Section 3.3.3. During anomalous propagation conditions, the RSL may fade but will not increase up more than 10 dB (except in unusual very long paths which may fade up by 15 dB).



Antenna alignment should enable the RSL to be peaked to the level calculated in the link budget. If the RSL is peaked but is approximately 20 dB below the calculated level, then it is likely that the antennas are aligned on a sidelobe of the antenna's radiated signal. In this case, the antennas should be rotated in a wide arc until the main lobe is located. (Other possible causes of low RSL are path obstructions, loss in connectors, adapters and pigtail jumper cables or different antenna polarization at each end of the link.)

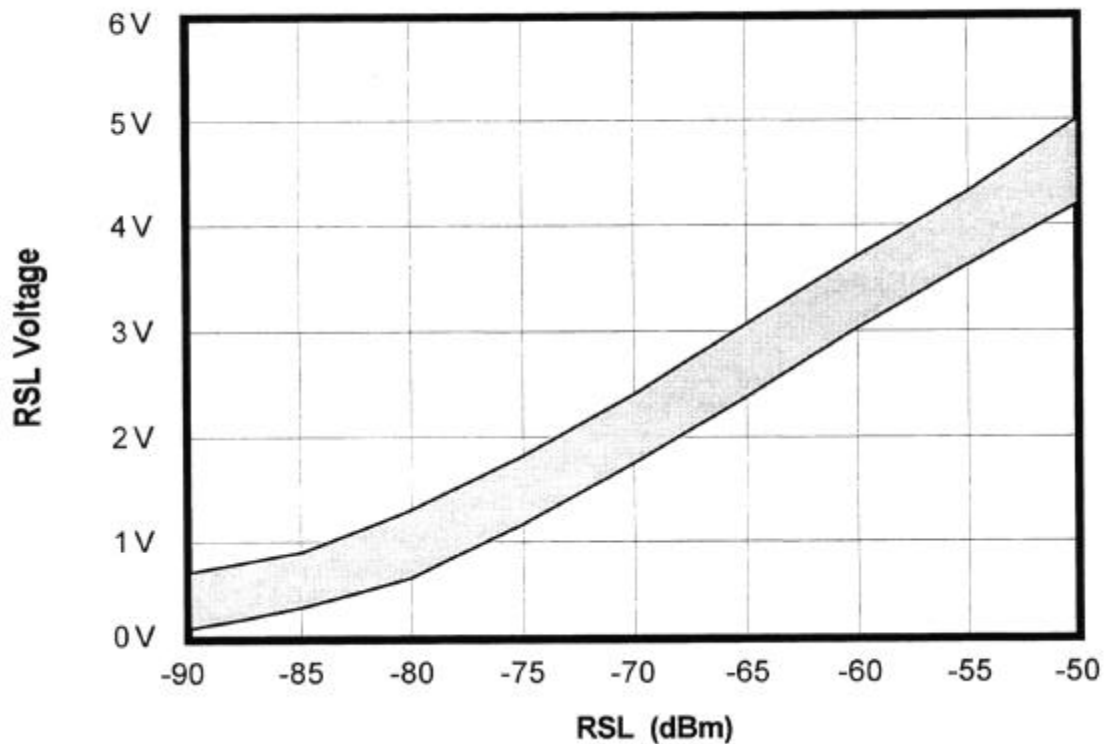

Figure 3-8: Typical RSL Voltage versus Received Signal Level (RSL)

3.11 Ethernet Interface Connection

The 10BaseT interface connection to the *Tsunami* radio is on the rear panel.



Additional external lightning protection devices are recommended for the connections if the radio is installed in an area prone to lightning.

The 10BaseT connection to the *Tsunami* is at the data interface on the rear of the shelf.

3.12 DIP Switch Settings

A quick reference guide to all DIP switches is provided in Appendix B.



DIP switch settings are noted by their position, either up (1), or down (0), not by on/off as may be printed on the DIP switch assembly.

3.12.1 Channel Selection

The *Tsunami* radio offers several frequencies of operation for the 2.4 GHz and the 5.8 GHz models (see Section 3.5). There are DIP switch segments (typical numbers 5 through 8 on SW3) which define the frequency channel plan of the *Tsunami* radio (refer to Appendix B). The DIP switches must be set to match the filter assembly that is mounted on the radio. For single and double capacity models, positions 5,6 and 7 define the frequency channel plan of the radio (e.g. B), the last DIP switch defines the transmit channel of the radio (e.g. A1 or A2).

Radios are shipped from the factory with their DIP switch segments set to match the installed filter. In most cases, no modification of these switches is required. Also, there are labels on the RF filter illustrating the correct DIP switch settings. One label is right side up and the other is upside down. Set the DIP switch settings for the label that is right side up. If a new filter is installed, or the existing filter is rotated for opposite channel configuration (e.g. A1 to A2), reset the DIP switches to match the right side up label on the filter. Refer to Section 4.2 for more information.

The radio channel selection is user adjustable by removing and replacing, or reversing the filter assembly. This allows units of the same radio model to be used as spares for several channels. For example, if a network of *Tsunami* radios has several radios using all three channel plans at 5.8 GHz, a single spare unit of any channel plan can be used to spare all the radios. If a radio failure were to occur in the network, the filter assembly of the failed unit would be removed and replace the filter assembly in the spare radio. The DIP switch segments on the spare may need to change to match the installed filter and the spare radio could be put into service.



The DIP switch setting must match the filter assembly mounted on the radio. Also, both radios of a link must have opposite channel plans (e.g. A1 and A2).



Consult Section 4.2 of this manual for more information on changing RF channels. Consult Appendix B for proper frequency channel switch settings.



Other NON-standard frequency plans may be offered in the future. In these cases, follow the DIP switch setting on the filter label.

3.12.2 Spreading Code Selection

The spreading code is the pseudo-random chip sequence that is mixed with the data to produce the spread spectrum signal. The spreading code is generated by the *Tsunami* radio internally. Different codes can be selected using the DIP switches on the *Tsunami* radio rear panel.



*The spreading code **must** be the same for both ends of a radio link.*



*The spreading code has no effect with the Model 31850 or (8Mbps) or Model 31145 (12 Mbps) *Tsunami* radios.*

Spreading codes are all set in the factory to code 1. Should the code need to be changed, then both ends of the link must be changed.

Changing the spreading code is an out-of-service adjustment. There are two DIP switch segments on SW3 located on the rear panel which select the spreading codes. See Figure 3-9 for DIP switch segment settings.

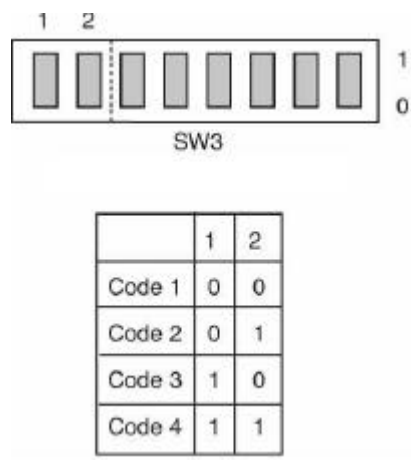

Figure 3-9: Spreading Code Selection

3.13 System Turn-up to Service

1. Prior to installing the system, it may be desirable to perform a back-to-back test of the *Tsunami* radio pair. Consult Section 4.9 for further details. Back-to-back testing is a simple way to verify that the *Tsunami* radios are fully operational before they are installed. Installation adds several variables (such as antenna alignment) which can lead to system turn-up delays. Also, during back-to-back testing, the DIP switch settings and some connections can be tested. This step can eliminate a majority of troubleshooting once the radios are installed.



A cellular phone or two-way radio system (walkie talkie, CB, mobile radio) can be very useful during installation. These can be used for temporary near-end and far-end communications between the installation personnel at one site and installation personnel at the other site while installing the system. These can also be helpful for communication between a person at the top of a very tall tower and ground personnel.



The Tsunami radio incorporates an internal Orderwire feature that provides end-to-end "telephone" style communications. However, the link must be partially operational to use this feature. In lieu of, or in addition to the use of cellular phones or two-way radio, this Orderwire feature can also be very useful for installation, but typically cannot be put into service until step 8 or 9 of this procedure is completed. See Section 3.14.1 for more details.

2. Perform a general alignment of the antennas on both ends of the path using binoculars, compass or other related tools. It is important to have the antennas aligned as accurately as possible before putting radio traffic over the link. This will help in getting the system running more rapidly. See Section 3.10 for more details.
3. Connect the transmission line to the antenna, and feed it to the *Tsunami* radio location (see Section 3.9). Connect the opposite end of the transmission line to the N-type female connector located on the filter assembly which occupies the top half of the *Tsunami* rear panel. The connection must be terminated into an antenna or a load before DC power is applied to the radio.
4. Verify that DIP switch settings for frequency channel selection match that of the filter that is installed on the rear of the radio. Consult 3.12.1 for further details. The far-end radio must have the same channel plan (e.g. A, B, C) as the near-end radio, and the opposite Tx and Rx frequencies (e.g. A1 and A2 make up a matched pair of radios).
5. Verify that the DIP switch settings for spreading code are the same for both ends of the radio link (see Section 3.12.3).
6. With the DC power source active, but not plugged into the *Tsunami* radio, using a voltmeter, confirm that the DC mating connector has the proper power connections in accordance with Section 3.7. Verify the polarity and the absolute voltage on all pins. Verify ground connection for power.

7. Connect power to the *Tsunami* radio. Verify that the Front Panel "ON" LED indication is illuminated. This confirms that power has been properly applied.



Ensure that the RF Antenna port connection is properly terminated before applying power to the Tsunami terminal, as in step 3.



When the Tsunami radio is initially powered-on, some alarm conditions may be present. This is normal and alarms can be ignored at this time.

8. Place a voltmeter across the GND and PWR front panel test points. See Figure 3-8 and 3-9 for voltage setting information and Table 3-C for typical output power levels for given cable lengths where EIRP limits apply. If necessary, use a small screwdriver at the front panel receptacle to adjust the output power of the local transmitter in accordance with the path analysis calculations. The recessed potentiometer is rotated clockwise to increase transmit output power and counter clockwise to decrease transmit output power. After verifying correct setting of the transmit output power, disconnect the voltmeter. Place the cover cap found in the installation accessory kit over the front panel receptacle.



The Tsunami radio requires professional installation. With some Tsunami models, in certain countries, there may be Effective Isotropic Radiated Power (EIRP) limits which dictate the maximum output power that the Tsunami radio can transmit given the transmission line loss and the gain of the antenna. Consult with appropriate government agencies or Western Multiplex if there is any question regarding maximum output power allowed.



In the USA, 5.8 GHz models may be operated at full power. 2.4 GHz models may require a power reduction of 1 dB from +30 dBm input power, as measured at the antenna feed, for every 3 dB that the antenna gain exceeds +6 dB.

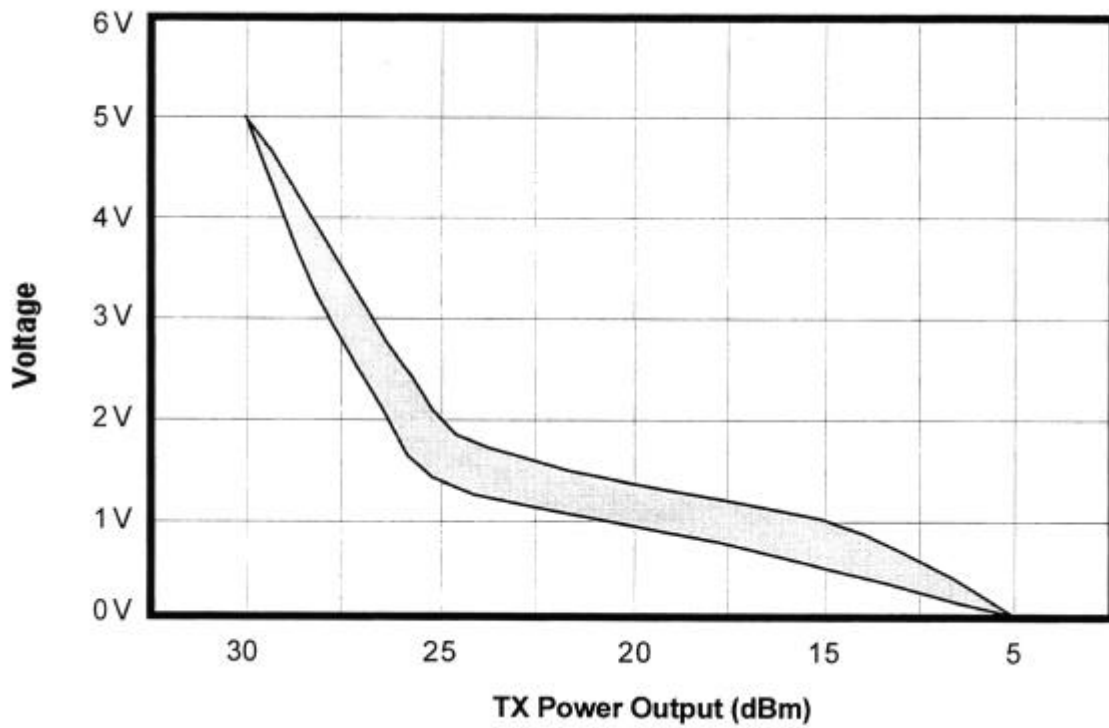

Figure 3-10: Typical RF Output Power versus PWR Voltage, 2.4 GHz Models



Use the Tsunami Factory Test Data sheet to determine more precisely the voltage corresponding to the RF output power.

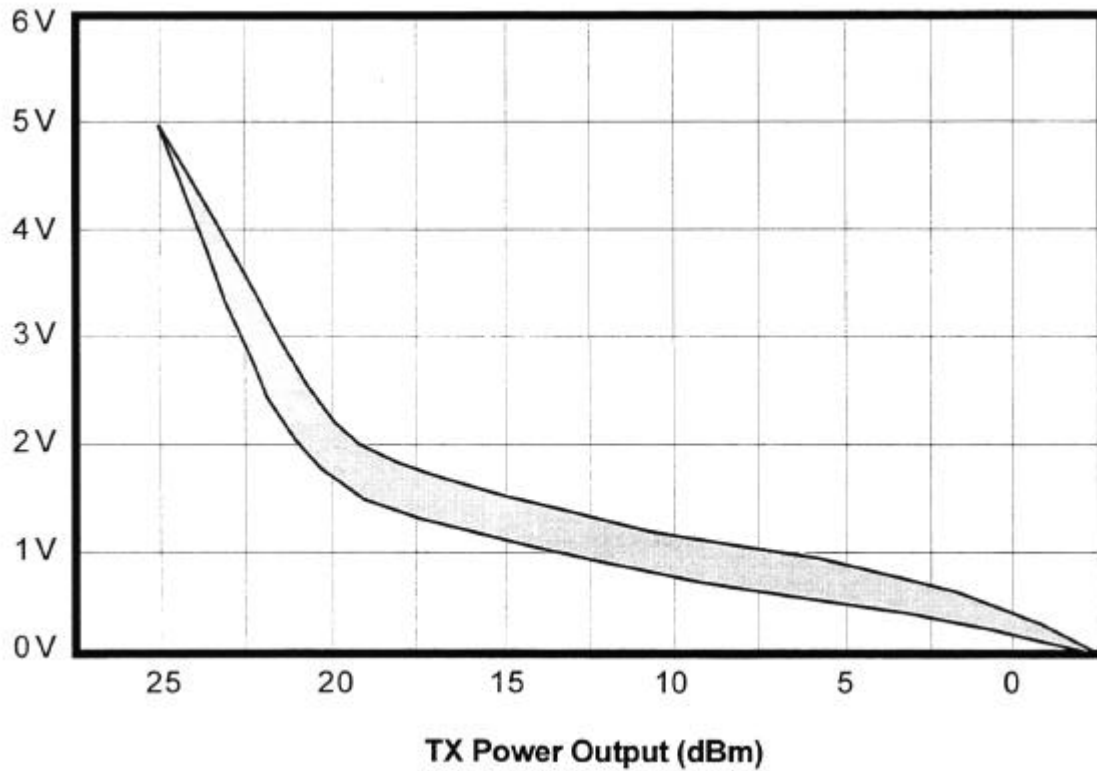

Figure 3-11: Typical RF Output Power versus PWR Voltage, 5.8 GHz Models



Use the Tsunami Factory Test Data sheet to determine more precisely the voltage corresponding to the RF output power.



For precision measurement of transmit output power, it is best to connect an RF power meter to the antenna port. The PWR port voltage may not provide enough precision. This is especially important where EIRP limits apply to the installation.



In cases of no EIRP limits, the radio transmitter output power can be adjusted to maximum for installation, except for very short paths using very high gain antennas, where excessive power may not be advised.



Don't forget that the RF output port should be terminated at all times when power is applied to the Tsunami radio. Therefore, disconnect power to the radio before connecting a power meter and reapply power once connected. Often, an RF power meter may have a limit to the input power that it can measure without damage. It is advised to place a calibrated fixed value RF attenuator (typically 20 dB or more) between the Tsunami radio and the power meter to assure proper operation and safety for the RF power meter. The value of this fixed attenuation can then be added to the value of the RF power meter reading to obtain the actual Tsunami radio transmitter output power.

9. Connect a voltmeter across the GND and RSL front panel test points. This voltage reading corresponds to the Received Signal Level (RSL) of the near-end radio. In other words, RSL is the "amount" of signal the near-end radio is receiving from the far-end radio. Since the antennas have not been finely aligned, it is not expected at this time that the RSL will read very high. However, at this point it can be verified that some communication is taking place between the two *Tsunami* terminals. Use the RSL voltage reading to align the antennas. Align one antenna at a time in accordance with Section 3.10. Complete alignment of both ends of the radio link before going further.



The RSL voltage output on the radio's front panel will output a voltage range over the full receiving capability of the radio (approximately 10 VDC at 0 dBm to 0.0 VDC at threshold).

The *Tsunami* radio has a unique feature of allowing measurement of the far-end RSL from the near-end radio. This is only possible if the *Tsunami* radios are communicating (the RSL is above threshold). The far-end RSL can be used to verify that adjustments to local antenna alignment are corresponding to the far-end radio reception. Far-end RSL is measured by pressing and holding the DISPLAY FAR END front panel button. While this button is held, the RSL voltage indicates the RSL of the far-end radio. RSL of both ends should be verified to be within approximately 2 dB of predicted value (see Section 3.3.3). There are several factors that can contribute to low RSL:

- Incorrect antenna alignment (aligned on a lobe and not on the main signal)
- Improper polarization alignment of antennas (horizontal vs. vertical)
- Transmission line problems (loose connections, bent or damaged cables, lossy adapters)
- Path obstructions (trees, buildings, hills, etc.)
- Path clearance (line-of-sight, earth curvature, Fresnel zone, diffraction and partial obstruction)
- Weather (inversion layers, ducting and multipath)

- Antenna feed (coaxial/connector) problem



The Tsunami radio requires professional installation. Don't forget that the transmitter output power adjustment on the Tsunami radio effects the RSL. Depending on EIRP limits (if any), path distance, and antenna gain, you may need to adjust the output transmit power to the proper level before putting the radios in service.



If radio synchronization has been established, the radio link may be able to provide some limited communications over the link. It can be helpful to establish voice communications from one end of the radio link to the other using the Orderwire feature of the Tsunami radio. See Section 3.14.1 for details.

If RSL is lower than anticipated, recheck the path clearance and transmission line as these are the typical causes of low RSL. Radio operations can be verified by connecting radios back-to-back with attenuators (40-60 dB), (see Section 4.9). If the problem remains, consult Section 4 of this manual for troubleshooting techniques which will help determine the source of the problem.

10. Once RSL is verified to be near the predicted value, the radio link is ready for data. You may verify error-free operation by using the link test function, as described in Section 3.13.2. If the link is not error-free, see Section 4.7 for troubleshooting guidelines.
11. Once radio performance is verified and acceptable, with link test mode turned off (press the ENABLE button, the LED will turn off), the *Tsunami* radios can now be put into service with the intended Ethernet traffic. Connect to the LAN or computer using the RJ45 10BaseT connector. With Ethernet traffic applied in both directions, all front panel LEDs, except for POWER and the data TXD/RXD lights should be off. If any other LEDs are on, consult the trouble shooting sections of this manual.
12. Now that the link is operational, other services can be connected including Orderwire, Diagnostics, Alarms and Aux Data (Service Channel). Consult Section 3.14 for details on these connections.



		TRANSMITTER POWER (dBm)													
Feeder Length Meters	Feeder Length Feet	2.4 GHz, 1/2" Coax			2.4 GHz, 7/8" Coax			5.8 GHz, 1/2" Coax				5.8 GHz, EW52 Waveguide			
		4' Dish	6' Dish	8' Dish	4' Dish	6' Dish	8' Dish	2' Dish	4' Dish	6' Dish	8' Dish	2' Dish	4' Dish	6' Dish	8' Dish
3.0	10	9.4	4.9	3.4	9.2	4.7	3.2	7.7	1.7	-1.3	-4.3	7.1	1.1	-1.9	-4.9
6.1	20	9.8	5.3	3.8	9.4	4.9	3.4	8.3	2.3	-0.7	-3.7	7.3	1.3	-1.7	-4.7
9.1	30	10.1	5.6	4.1	9.7	5.2	3.7	9.0	3.0	0.0	-3.0	7.4	1.4	-1.6	-4.6
12.2	40	10.5	6.0	4.5	9.9	5.4	3.9	9.6	3.6	0.6	-2.4	7.5	1.5	-1.5	-4.5
15.2	50	10.9	6.4	4.9	10.1	5.6	4.1	10.3	4.3	1.3	-1.7	7.7	1.7	-1.3	-4.3
18.3	60	11.3	6.8	5.3	10.3	5.8	4.3	11.0	5.0	2.0	-1.0	7.8	1.8	-1.2	-4.2
21.3	70	11.7	7.2	5.7	10.5	6.0	4.5	11.6	5.6	2.6	-0.4	7.9	1.9	-1.1	-4.1
24.4	80	12.0	7.5	6.0	10.8	6.3	4.8	12.3	6.3	3.3	0.3	8.0	2.0	-1.0	-4.0
27.4	90	12.4	7.9	6.4	11.0	6.5	5.0	12.9	6.9	3.9	0.9	8.2	2.2	-0.8	-3.8
30.5	100	12.8	8.3	6.8	11.2	6.7	5.2	13.6	7.6	4.6	1.6	8.3	2.3	-0.7	-3.7
33.5	110	13.2	8.7	7.2	11.4	6.9	5.4	14.3	8.3	5.3	2.3	8.4	2.4	-0.6	-3.6
36.6	120	13.6	9.1	7.6	11.6	7.1	5.6	14.9	8.9	5.9	2.9	8.6	2.6	-0.4	-3.4
39.6	130	13.9	9.4	7.9	11.9	7.4	5.9	15.6	9.6	6.6	3.6	8.7	2.7	-0.3	-3.3
42.7	140	14.3	9.8	8.3	12.1	7.6	6.1	16.2	10.2	7.2	4.2	8.8	2.8	-0.2	-3.2
45.7	150	14.7	10.2	8.7	12.3	7.8	6.3	16.9	10.9	7.9	4.9	9.0	3.0	0.0	-3.0
48.8	160	15.1	10.6	9.1	12.5	8.0	6.5	17.6	11.6	8.6	5.6	9.1	3.1	0.1	-2.9
51.8	170	15.5	11.0	9.5	12.7	8.2	6.7	18.2	12.2	9.2	6.2	9.2	3.2	0.2	-2.8
54.9	180	15.8	11.3	9.8	13.0	8.5	7.0	18.9	12.9	9.9	6.9	9.3	3.3	0.3	-2.7
57.9	190	16.2	11.7	10.2	13.2	8.7	7.2	19.5	13.5	10.5	7.5	9.5	3.5	0.5	-2.5
61.0	200	16.6	12.1	10.6	13.4	8.9	7.4	20.2	14.2	11.2	8.2	9.6	3.6	0.6	-2.4
64.0	210	17.0	12.5	11.0	13.6	9.1	7.6	20.9	14.9	11.9	8.9	9.7	3.7	0.7	-2.3
67.1	220	17.4	12.9	11.4	13.8	9.3	7.8	21.5	15.5	12.5	9.5	9.9	3.9	0.9	-2.1
70.1	230	17.7	13.2	11.7	14.1	9.6	8.1	22.2	16.2	13.2	10.2	10.0	4.0	1.0	-2.0
73.2	240	18.1	13.6	12.1	14.3	9.8	8.3	22.8	16.8	13.8	10.8	10.1	4.1	1.1	-1.9
76.2	250	18.5	14.0	12.5	14.5	10.0	8.5	MAX	17.5	14.5	11.5	10.3	4.3	1.3	-1.7
79.2	260	18.9	14.4	12.9	14.7	10.2	8.7	MAX	18.2	15.2	12.2	10.4	4.4	1.4	-1.6
82.3	270	19.3	14.8	13.3	14.9	10.4	8.9	MAX	18.8	15.8	12.8	10.5	4.5	1.5	-1.5
85.3	280	19.6	15.1	13.6	15.2	10.7	9.2	MAX	19.5	16.5	13.5	10.6	4.6	1.6	-1.4
88.4	290	20.0	15.5	14.0	15.4	10.9	9.4	MAX	20.1	17.1	14.1	10.8	4.8	1.8	-1.2
91.4	300	20.4	15.9	14.4	15.6	11.1	9.6	MAX	20.8	17.8	14.8	10.9	4.9	1.9	-1.1
94.5	310	20.8	16.3	14.8	15.8	11.3	9.8	MAX	21.5	18.5	15.5	11.0	5.0	2.0	-1.0
97.5	320	21.2	16.7	15.2	16.0	11.5	10.0	MAX	22.1	19.1	16.1	11.2	5.2	2.2	-0.8
100.6	330	21.5	17.0	15.5	16.3	11.8	10.3	MAX	22.8	19.8	16.8	11.3	5.3	2.3	-0.7
103.6	340	21.9	17.4	15.9	16.5	12.0	10.5	MAX	MAX	20.4	17.4	11.4	5.4	2.4	-0.6
106.7	350	22.3	17.8	16.3	16.7	12.2	10.7	MAX	MAX	21.1	18.1	11.6	5.6	2.6	-0.4
109.7	360	22.7	18.2	16.7	16.9	12.4	10.9	MAX	MAX	21.8	18.8	11.7	5.7	2.7	-0.3
112.8	370	23.1	18.6	17.1	17.1	12.6	11.1	MAX	MAX	22.4	19.4	11.8	5.8	2.8	-0.2
115.8	380	23.4	18.9	17.4	17.4	12.9	11.4	MAX	MAX	MAX	20.1	11.9	5.9	2.9	-0.1
118.9	390	23.8	19.3	17.8	17.6	13.1	11.6	MAX	MAX	MAX	20.7	12.1	6.1	3.1	0.1
121.9	400	24.2	19.7	18.2	17.8	13.3	11.8	MAX	MAX	MAX	21.4	12.2	6.2	3.2	0.2

Table 3-C: Transmitter Output Power Adjustment, +6 dBW EIRP Installations
 (Such as Canada)

Feeder Length Meters	Feeder Length Feet	TRANSMITTER POWER (dBm)					
		2.4 GHz, 1/2" Coax			2.4 GHz, 7/8" Coax		
		4' Dish	6' Dish	8' Dish	4' Dish	6' Dish	8' Dish
3.0	10	23.4	22.0	21.2	23.2	21.9	21.1
6.1	20	23.8	22.4	21.6	23.5	22.1	21.3
9.1	30	24.1	22.8	22.0	23.7	22.4	21.5
12.2	40	24.5	23.2	22.4	23.9	22.6	21.8
15.2	50	24.9	23.6	22.7	24.2	22.8	22.0
18.3	60	25.3	23.9	23.1	24.4	23.0	22.2
21.3	70	25.7	24.3	23.5	24.6	23.3	22.4
24.4	80	26.0	24.7	23.9	24.8	23.5	22.7
27.4	90	26.4	25.1	24.3	25.1	23.7	22.9
30.5	100	26.8	25.5	24.6	25.3	24.0	23.1
33.5	110	27.2	25.8	25.0	25.5	24.2	23.4
36.6	120	27.6	26.2	25.4	25.8	24.4	23.6
39.6	130	27.9	26.6	25.8	26.0	24.7	23.8
42.7	140	28.3	27.0	26.2	26.2	24.9	24.1
45.7	150	28.7	27.4	26.5	26.5	25.1	24.3
48.8	160	29.1	27.7	26.9	26.7	25.3	24.5
51.8	170	29.5	28.1	27.3	26.9	25.6	24.7
54.9	180	29.8	28.5	27.7	27.1	25.8	25.0
57.9	190	MAX	28.9	28.1	27.4	26.0	25.2
61.0	200	MAX	29.3	28.4	27.6	26.3	25.4
64.0	210	MAX	29.6	28.8	27.8	26.5	25.7
67.1	220	MAX	MAX	29.2	28.1	26.7	25.9
70.1	230	MAX	MAX	29.6	28.3	27.0	26.1
73.2	240	MAX	MAX	MAX	28.5	27.2	26.4
76.2	250	MAX	MAX	MAX	28.8	27.4	26.6
79.2	260	MAX	MAX	MAX	29.0	27.6	26.8
82.3	270	MAX	MAX	MAX	29.2	27.9	27.0
85.3	280	MAX	MAX	MAX	29.4	28.1	27.3
88.4	290	MAX	MAX	MAX	29.7	28.3	27.5
91.4	300	MAX	MAX	MAX	29.9	28.6	27.7
94.5	310	MAX	MAX	MAX	MAX	28.8	28.0
97.5	320	MAX	MAX	MAX	MAX	29.0	28.2
100.6	330	MAX	MAX	MAX	MAX	29.3	28.4
103.6	340	MAX	MAX	MAX	MAX	29.5	28.7
106.7	350	MAX	MAX	MAX	MAX	29.7	28.9
109.7	360	MAX	MAX	MAX	MAX	29.9	29.1
112.8	370	MAX	MAX	MAX	MAX	MAX	29.3
115.8	380	MAX	MAX	MAX	MAX	MAX	29.6
118.9	390	MAX	MAX	MAX	MAX	MAX	29.8
121.9	400	MAX	MAX	MAX	MAX	MAX	30.0

Table 3-D: Transmitter Output Power Adjustment for 2.4 GHz, USA Installations

3.13.1 Output Power Adjustment

The *Tsunami* radio requires professional installation. In certain cases, it is necessary to adjust the output power from the factory setting, for example:

- ❖ to meet EIRP (effective isotropic radiated power) limits, such as +6 dBW in Canada.
- ❖ to meet transmitter output limits in the 2.4 GHz band for USA installations.
- ❖ to avoid exceeding the maximum far-end RSL of 0 dBm.
- ❖ to coordinate a hub or repeater location.



To ensure maximum protection of the radio circuits, always ensure the antenna connector is terminated when power is applied.

For precise measurement of transmitter power, a calibrated RF power meter (such as the HP 435B with Power Sensor HP8481) is recommended. This power sensor can be connected directly to the output of the radio without exceeding the power rating. With some power meters, it may be necessary to place a calibrated in-line fixed attenuator between the radio antenna port and the power meter so as to not exceed the power meter's maximum input level. Thru-line power meters do not operate at *Tsunami* RF frequencies.

If adjusting the output power to meet an EIRP limit, it will be first necessary to calculate the overall system gains and losses, including feeder losses for the type of transmission line installed and the antenna gain. Also refer to Table 3-C or 3-D for transmitter output power settings where installed with various transmission line lengths and antenna sizes. You may determine the radio transmit power for EIRP limited installations by the following equation:

$$\text{Tx Power (dBm)} = \text{EIRP Limit(dBm)} + \text{Feeder Loss(dB)} - \text{Antenna Gain(dB)}$$

In the USA, 2.4 GHz models have an output limit which is determined by:

$$\text{Tx Power (dBm)} = 30 - [(\text{Antenna Gain} - 6) / 3] + \text{Feeder Loss}$$

Output power may be adjusted using a small screwdriver and rotating the potentiometer which is recessed behind the front panel. Clockwise rotation increases output power while counter-clockwise rotation decreases output power.

In lieu of a calibrated RF power meter, the PWR test port voltage can be used to estimate the output power. Figures 3-18 & 3-9 illustrate the voltage reading for various output power levels. The factory test data sheet should be used to establish a more precise setting of this adjustment.



After setting the correct output power, place the cover cap found in the installation accessory kit over the front panel receptacle.

3.13.2 Link Testing

When a pair of *Tsunami* radios are installed and communicating with each other, a link test can be performed to evaluate the bridge performance.

The Tsunami uses an internal test signal for link test.

To test the link including the far-end radio, press ENABLE and hold for approximately 3 seconds, then release the ENABLE button on the front panel of the near-end radio. The ENABLE LED should now be blinking.



If the ENABLE link test button LED is illuminated and not blinking, this means the far-end radio has initiated link test manually.

When link test is enabled, the ERROR LED should not illuminate if the path is operating error-free. If the ERROR LED illuminates, this means that at least one bit error has occurred.

3.13.3 Error LED Mode Selection

The ERROR LED illuminates if any errors are present in the data stream during link test.

The default mode for this LED is “latched.” That is, when a single error occurs, the LED illuminates and stays lit until link test is turned off. This mode is especially useful for long term (overnight) testing, or any time that an operator is not watching the radio during testing.

There is an optional mode for this LED which is “unlatched.” This allows the user to “view” the error rate. In this mode, the LED will flash on each time a single or multiple error occurs. The LED turns off if no further errors occur. This mode can be useful if a BER test set is not available and the user wishes to determine the nature of any error conditions (bursting, dribbling, occasional).

In “unlatched” mode, when any errors occur, the ERROR LED will illuminate for a minimum of one second. If errors continue within this one second interval, the LED will remain on until there are no errors for 1 second.

The two modes for this LED are selected by a rear panel DIP switch, as shown in Figure 3-12.

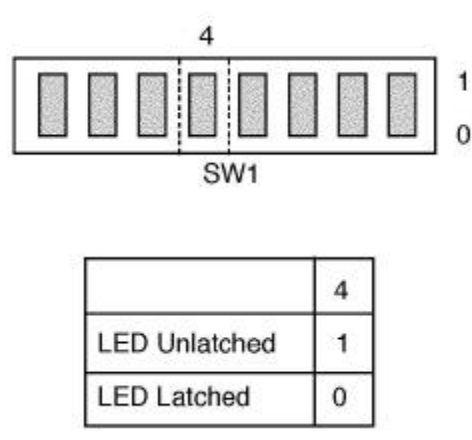

Figure 3-12: Error LED Mode Selection



In the LED unlatch mode, after 100 errors the ERROR LED will remain lit to indicate excessive errors.

3.14 Additional Connections

There are additional customer connections which are optional and are **not required** to make the *Tsunami* operational but may prove useful.

3.14.1 Orderwire Connection and Address Selection

Orderwire is a “telephone” type wayside service which allows users of the *Tsunami* radio to establish voice communications from one radio to another, either directly to the companion far-end, or through a repeater configuration, or several repeater configurations.

Telephone connection specifications:

REN (Ringer Equivalency Number)	1.0 B
DTMF tones	within $\pm 1.5\%$ of nominal freq.
Ringing Voltage	48 VDC, typical
(Ringing voltage is adequate for modern solid state ringers, NOT for the older mechanical type ringers)	

This Orderwire service does not affect the normal radio transmission of data traffic. Refer to Section 2.3.5 for the telephone specifications. For simple near-end to far-end communications, follow the steps below:

1. Using a small screwdriver, set the address of both terminals by rotating the address rotary selection switches on the rear panel of the *Tsunami* radio. The address is a two digit number (from 01 to 99). Each *Tsunami* terminal in the network should have a unique address. This address acts like a “phone number” for other users to call a particular terminal. Each *Tsunami* terminal should have a unique address.



Radio pairs (links) are shipped from the factory with addresses set to 01 or 02. Therefore, if only one pair is being used, address selection may not be necessary.

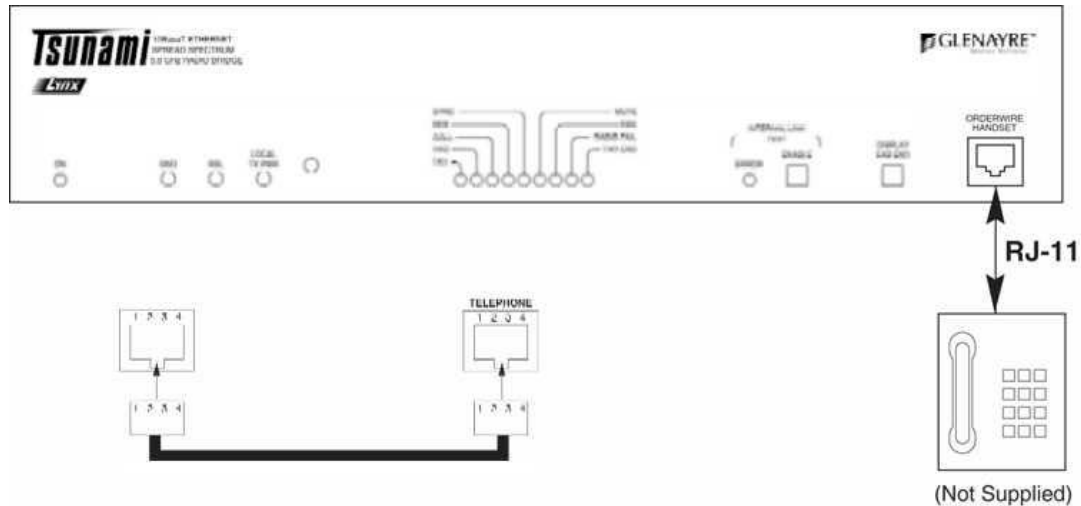

Figure 3-13: RJ-11 Orderwire Telephone Connection

2. Using a standard RJ-11 telephone cable, connect a standard electronic telephone (a touch tone phone, complete with dialer; a handset by itself will not work) to the Orderwire connector on the *Tsunami* front panel. This connector is wired identically to a standard two-wire telephone jack, see Figure 3-13 for details.
3. With a telephone connected to each *Tsunami* terminal on opposite ends of the link, either telephone can be used to “dial-up” the far-end location. Simply pick up the handset of the near-end telephone and dial the two-digit address of the far-end *Tsunami* terminal. The far-end terminal’s internal ringer and the connected telephone will ring, and if answered, two-way full-duplex voice communication is established.



If using the Orderwire or Network management functions, all Tsunami radios connected must have unique address settings (telephone numbers).



The orderwire address is set by two rotary switches on the rear panel of the Tsunami radio. Use a small screwdriver to select the orderwire address (01 through 99).

4. If the *Tsunami* radios are connected in a repeater configuration, Orderwire services can be established to all *Tsunami* terminals in the network by implementing a connection of their rear-panel connectors between repeater terminals. At the repeater site, a cable can be connected to the two *Tsunami* terminals between their rear panel VF 25-pin connectors as shown in Figure 3-14. With this cable in place, the Orderwire function will operate at terminals at each end of the repeater and at the repeater site. This function can be continued through several repeater sites if desired. For hub connections of 3 or more *Tsunami* radios at the same site, an external 4-wire bridge is required to connect all radios to the orderwire.



*The orderwire system can be integrated with orderwire equipment supported by many other vendors. If your existing orderwire network uses 2 digit addressing, and 0 dBm VF interface, it can be connected to a *Tsunami* as shown in Figure 3-18.*



*Dialing a * (star key) on the orderwire telephone implements an “all call” feature which rings all connected radios. Also, if a phone anywhere in the connected network has accidentally been left off-hook, the # (pound key) key can be used to mute all off-hook handsets until they are placed on and off hook again.*



The orderwire operates like a “party line”. All telephones provide communication to all other telephones in the connected network. Even if a particular telephone does not ring, it can still be used to talk and listen to any ongoing orderwire activity if the orderwire is in use at other terminal locations.

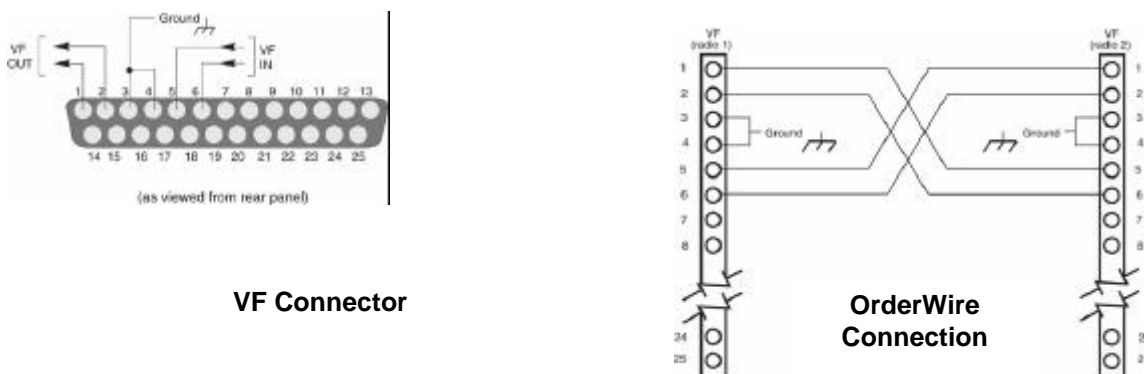

Figure 3-14: VF Port Connection

3.14.2 Alarm Connections

External alarm outputs are provided at the 25-pin, D-type subminiature ALARM connector. There are two Form C summary alarm relays capable of switching 30 VDC at 1 A. Also, individual alarm logic outputs capable of sourcing and sinking 1mA are provided. These individual alarms interface to a single standard TTL load. When the unit is IN ALARM = "0", the TTL output is 0 V to ± 0.5 V. When the unit is NO ALARM = "1", the TTL output is +3.5 V to +5.5 V. See Table 3-E and Figure 3-15 for Alarm Connections.

The "summary" alarm (Form C relay) is activated by any near-end front panel LED alarm condition, including if the internal link test mode is enabled.

The "out-of-service summary" alarm (Form C relay) is activated by any of the following alarm conditions:

- ❖ RX SYNC
- ❖ Radio Fail
- ❖ Link Test Enabled

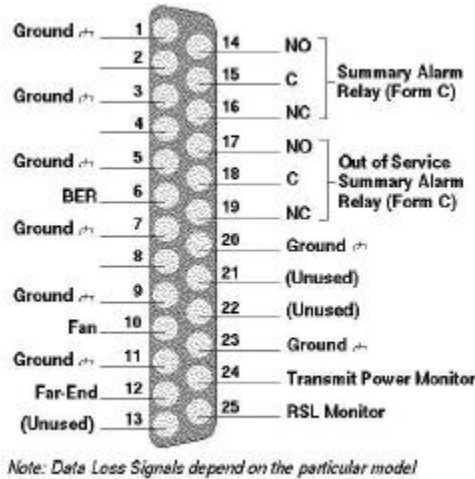

Figure 3-15: Pin Connections, ALARM Interface

PIN 2	Not used	PIN 16	NC, SUMMARY ALARM, FORM C - normally closed connection on summary alarm relay.
PIN 4	Not used	PIN 17	NO, OUT OF SERVICE SUMMARY ALARM, FORM C - normally open connection on out-of-service summary alarm relay. Closed when in alarm.
PIN 6	BER - in alarm when the received signal is degraded to an high error rate.	PIN 18	C, OUT OF SERVICE SUMMARY ALARM, FORM C - common connection for the out-of-service summary alarm relay.
PIN 8	MUTED – If SW1-5 has been toggled ON, the mute function is disabled. Enabled, mute indicates an alarm condition that is one or both of the following: 1) The security address setting for switch 2 on the back of the radio does not match the radio bridge on the other end of the link. 2) There is an excessive number of data errors on the 10BaseT connection that the radio will not transmit so it MUTES the data from being sent.	PIN 19	NC, OUT OF SERVICE SUMMARY ALARM, FORM C - normally closed connection on out-of-service summary alarm relay. Open when in alarm.
PIN 10	FAN - in alarm when one or both of the internal fans are not operative.	PIN 21	NOT USED
PIN 12	FAR-END - in alarm when the far-end radio has an alarm condition.	PIN 22	NOT USED
PIN 14	NO, SUMMARY ALARM, FORM C - normally open connection on summary alarm relay. Closed when in alarm.	PIN 24	TX PWR MON - voltage equal to the TX PWR front panel voltage.
PIN 15	C, SUMMARY ALARM, FORM C - common connection on the summary alarm relay.	PIN 25	RSL MON - voltage equal to the RSL front panel voltage.
PINS 1, 3, 5, 7, 9, 11, 20, & 23		GROUND, CHASSIS CONNECTION	

Table 3-E: Alarm Interface Connections



*All alarms are active for a minimum of one second, or as long as the alarm condition persists, which ever is longer.
 TTL signals are "in alarm" when there is a TTL zero condition (0 V to ± 0.5 V).*

3.14.3 Diagnostics Port Operation

The Diagnostics Port is used to retrieve diagnostic about the *Tsunami* radios by means of a computer connection. This port is normally used only by Western Multiplex.

The diagnostics port allows connection of either EIA standard RS-232 or RS-422 devices to poll and receive status of the *Tsunami* radio. This serial port provides similar information to that which is normally available to a local operator by means of visual alarms and status (front panel LEDs, ADDRESS, DIP switch settings etc.), including voltage level measurements (such as RSL, PWR) and alarm port (see Section 3.14.2) status. The diagnostics port can also provide extended information including some advanced diagnostics and configuration information. Any information that is available on the far-end terminal is also available at the near-end Diagnostics port (such as far-end RSL, far-end alarms) by means of bridging the AUX DATA port (as described in Section 3.14.4). A DIP switch is used to define the command protocol for this port as shown in Figure 3-16. The default setting is for user data. The other setting is for factory use only.

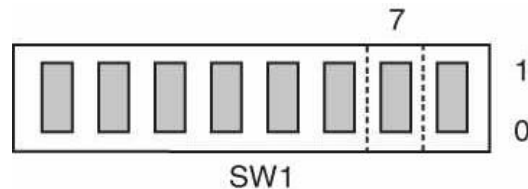

	7
Factory Test	1
TBOS	0

Figure 3-16: Diagnostic Port Protocol Selection

3.14.3.1 Diagnostics Port using RS-232

For RS-232 diagnostics connection to the *Tsunami* radio, connect the serial device (modem, computer, terminal) to the male 9-pin subminiature connector in accordance with Figure 3-17.

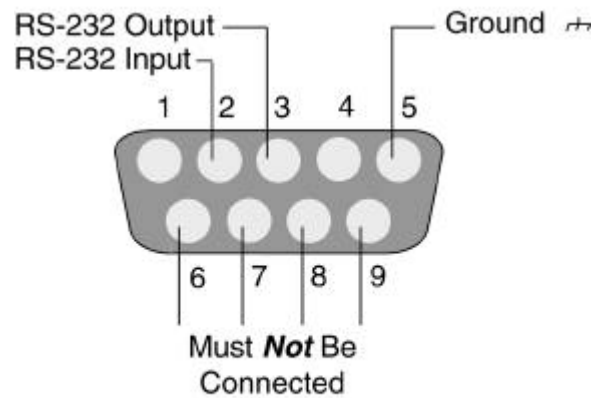

(as viewed from rear panel)

Figure 3-17: RS-232 Diagnostic Port Connections



Pins 6 through 9 must not be connected for RS-232 communications to operate properly.

3.14.3.2 Diagnostics Port using RS-422

For RS-422 Diagnostics connection to the *Tsunami* radio, connect to the serial device (modem, computer, terminal) to the male 9-pin subminiature connector in accordance with Figure 3-16.

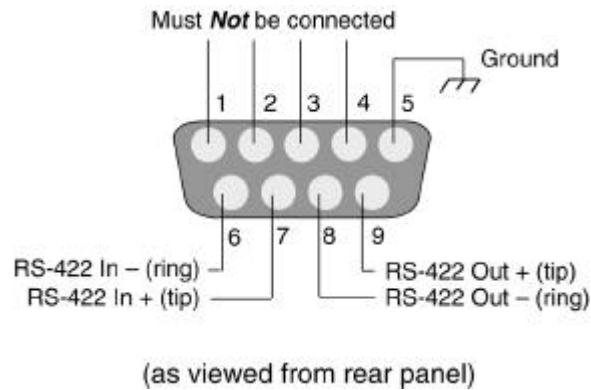

Figure 3-18: RS-422 Diagnostic Port Connections



Do not connect devices to both the RS-232 and RS-422 connections of the Diagnostics Port. This will cause data conflicts that will result in errors over the interface.

3.14.4 AUX DATA (Digital Service Channel) Connection

The AUX DATA port is a separate wayside serial port which can be configured to allow the connection of any user serial data (to 9600 baud) through the radio network. Connection to the AUX DATA port is an RS-232 or RS-422 serial interface, identical to the diagnostics port (see Section 3.14.3). This port does not affect the Ethernet traffic on the *Tsunami* radio.

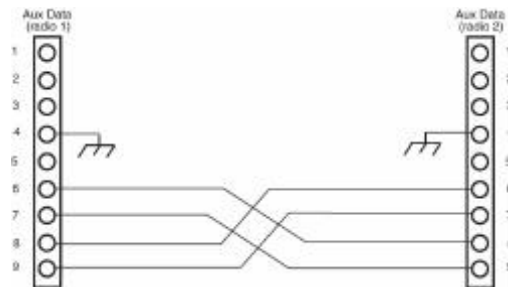
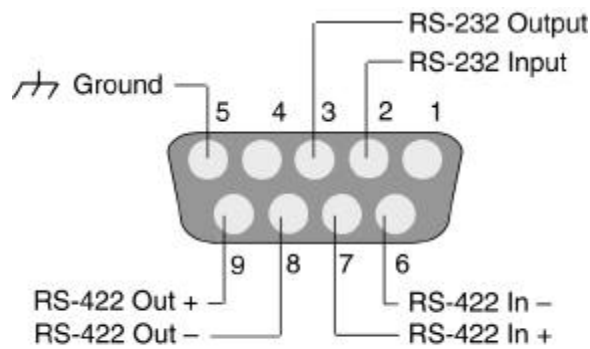

Figure 3-19: AUX DATA Cable Connection for Repeater/Hub

3.14.5 Fail-over option

A separate fail-over switch may be available as a future option (please consult the factory for availability).

A protection switch option will switch from one radio to another radio set up similarly at a radio site with each radio being monitored in order to provide an even higher reliability for the radio link.



Your Notes on the *Tsunami* Radio

4. Troubleshooting

4.1 Regular Maintenance

The *Tsunami* radios do not require any regular maintenance, however, it is prudent to monitor the radio link at regular intervals to assure that the link conditions are not changing. When visiting a radio site for maintenance, the following items may be checked and their results recorded:

- ❖ RSL Voltage
- ❖ PWR Voltage
- ❖ Far-end RSL Voltage
- ❖ Alarm conditions
- ❖ Verify radio has adequate ventilation

If any alarm conditions exist, they should be recorded, and troubleshooting procedures from this Section of the manual should be followed.

4.1.1 Throughput and Equipment

Also refer to Appendix E fold-out as an additional guide

Requirements for Full Duplex

For a network to support Full Duplex, both devices must support and be configured for Full Duplex. Full Duplex is intended to increase the speed of a direct link between two devices. i.e., between switches, or between an end-station and a switch. Switches support Full Duplex, hubs do not. Configuring an adapter for Full Duplex operation while connected to a hub or other half duplex device (NIC, etc.), can cause many network issues such as slowness, packet loss or station drop-offs.

What is Auto-Negotiation?

Auto-Negotiation is a protocol between devices where they negotiate highest common speed. Also known in the industry as NWAY. Since every frame is tested for speed and configuration, auto-negotiation takes away from the maximum bandwidth possible through a network. When possible, do not use auto-negotiation especially when the port configuration is known (e.g. 10 or 100Base, half or full duplex, etc.). Tsunami radios are especially sensitive and work best only with devices hard set to the radio's configuration (e.g. full duplex, 10BaseT) and NOT in auto-negotiation nor auto-sense.

What is the difference between 10 and 100BaseT (or F)?

These are fully different and mostly incompatible Ethernet communication. Ten (10)Base is any throughput speed from 1bps to 10Mbps, 100Base (also known as Fast Ethernet) is any throughput from 1bps to 100Mbps with the 10BaseT standard NOT capable of transmitting the full throughput of a 100Base device. Each has its own set of communication rules and need to be considered separately when communicating with either standard. Many hubs, switches and routers will auto-negotiate between these two speeds, but Tsunami radios (in order to maximize their throughput) do NOT auto-negotiate. Many throughput problems have been found when the computer's Ethernet NIC card is set to auto-negotiate when it should be set (through Network Properties) to NOT auto-negotiate. Although if the switch, router or NIC is set for auto-negotiation, the interface will function but the throughput speed can suffer considerably and high latency can result. All NICs & routers and most "managed" switches can be hard set or programmed to not auto-negotiate (both 10/100Base and full/half duplex) and is the desired set-up for maximum Ethernet throughput with any network especially those with wireless components.

Hub Vs Switch

All the devices connected to a hub are in the same collision domain. These devices share the bandwidth of the hub (10 Mbps for Ethernet or 100 Mbps for Fast Ethernet). By contrast, each port of a switch is actually the entrance to a separate collision domain with its own dedicated bandwidth. Each domain is either shared by other devices or dedicated to a single device. If many devices and the network is utilized over 25%, a switch is necessary to optimize Ethernet traffic. If economics allow, a programmable or managed switch is desirable for many reasons such as for the reasons above and that spanning tree can be easily accomplished if needed in a network.

Response time slower with switch than it was with a hub

Low volume on the network could cause a slowness in performance when a switch is introduced into an environment where a hub was used previously. There may not be enough traffic on the network to warrant a switch. When network utilization starts to reach 25 - 30%, the conditions are good for a switching product.

4.2 Changing Frequency Plans

The *Tsunami* RF frequency selections are listed in Section 3.5. The near-end radio and the far-end radio must be corresponding (e.g. A1 / A2). The frequency of a given *Tsunami* terminal is set by the specific filter, the physical orientation of this assembly, and the setting of corresponding DIP Switches. (See Section 3.12.1 for more details.)

With respect to a given filter, the frequencies are fixed, because tuned RF filters are required for normal operation. Changing of the (pretuned) radio frequencies may be required when installing spares or for special situations, such as interference mitigation. This is accomplished by installing an alternate filter or reorienting the existing filter.

For any given model of *Tsunami*, the frequency channel can be changed by swapping and /or reorienting the filter.



It is not necessary to remove the cover assembly of the Tsunami

1. Remove any cables connected to the antenna connector on the diplexer (filter) and then remove the two screws which mount the filter to the *Tsunami* chassis.
2. Slowly remove the filter from the chassis being careful to not endanger the cables that are connected to the rear side of the filter.
3. Disconnect the two SMA connectors that are attached to the rear of the filter with a 5/16" open end wrench.
4. Select the new filter or orient the existing filter such that the frequency channel label on the filter (showing the DIP switch positions) is right-side-up corresponding to the desired frequency channel.
5. Connect the two SMA connectors to the new or reoriented filter with the 5/16" open end wrench.
6. Slowly place the wired filter assembly so that it is flush with the rear panel.
7. Install the two screws which mount the filter to the rear panel.
8. Refer to the rear panel filter label or Section 3.12.1 for DIP Switch settings to correspond to the new filter and reattach the antenna cable.



As an example, the filter assemblies of an A1 and A2 terminal are identical. They are simply installed differently. An A1 terminal can be changed into an A2 by removing the filter and rotating it 180 degrees and reinstalling the filter. The DIP switch positions need to match the filter orientation, per the appropriate filter label.

4.3 Using a Spare Terminal

One spare *Tsunami* terminal of a given model type will service any other radio in that same model type, independent of frequency channel plan. For example, a similar model 5.8 GHz channel A2 can be used as a spare for any A, B or C channel radio at 5.8 GHz. See Section 4.2 for changing frequencies of a spare radio.

Customers with several radios, or radios in critical operations are encouraged to purchase one or more spare radios of each model in their system. This will allow rapid restoration of radio service in the unlikely event of a radio failure.

4.4 Technical Support

Western Multiplex provides 24-hour telephone technical support for installed *Tsunami* radios. Customers are encouraged to troubleshoot the radio and link in accordance with the latter part of this section in this manual before contacting Western Multiplex. Western Multiplex also has a limited supply of *Tsunami* radios that can be loaned to out-of-service customers for installation while units are being repaired. Loaner supply is limited, and is only used for critical applications on a first-come, first-served basis.

Customer service #: +1 408 542-5390

4.5 Repair Policy

The *Tsunami* terminal includes comprehensive alarm indicators designed to diagnose potential faults. Should a fault occur, it often may be resolved by operator adjustment.

Should a fault occur that cannot be resolved by operator adjustment and has been confirmed by looping terminals together on the bench (See Section 4.9), then the equipment should be returned to the factory for repair.

The *Tsunami* radio is a complex system not designed for user repair. Do not remove the cover or open any part of the *Tsunami* terminal. The complete *Tsunami* terminal should be sent back in its original packing material for factory repair.

Please contact the factory in advance of returning the product. You will be assigned a Return Material Authorization (RMA) number that authorizes your return. Units sent to the factory without an RMA number may be delayed in the processing of the repair. Be sure to include the following information:

- ❖ RMA number
- ❖ description of the problem
- ❖ your name and telephone number
- ❖ return shipping address
- ❖ urgency of repair



Please refer to the published Warranty policy for repair policy details.



Tsunami radios should be packaged in their original packing boxes for shipment whenever possible. Western Multiplex can provide an empty box shipment to facilitate proper packaging. Regardless, proper and adequate packaging must be used for shipments to protect the radio(s) from damage. Western Multiplex can not be held responsible for any repairs due to inadequately packed materials. Damage caused by improper packing will likely result in higher repair costs and delays (refer to the Warranty section at the beginning of this manual).

4.6 Front Panel Status LEDs

There are several front panel status LEDs on the *Tsunami* radio. These LEDs indicate conditions where either a hardware failure has occurred or the radio link is not optimum. In many cases, a combination of LEDs may be illuminated. The following sections describe the necessary troubleshooting procedures should any LED(s) indicate a problem during or after installation.

4.6.1 BER (Bit Error Rate) Alarm

Function:

This LED indicates that the traffic being received from the far-end radio is exceeding the bit error rate threshold of the radio (approximately 1×10^{-6}). This indicates that radio traffic currently has errors on it which may exceed acceptable levels. This LED will stay ON as long as the BER threshold is being exceeded. In some cases, it will turn ON and OFF, in which case there are bursts of errors causing intermittent degradation to the received data. In all cases, the LED will be on for at least 1 second for any group of errors which exceed the threshold, whether they are a burst of errors or a long string of errors.



If the RX SYNC alarm is ON, the near-end or far-end radio in addition to the BER alarm (on the same radio); the RX SYNC alarm should be the first priority for troubleshooting.

Possible Causes:

- ❖ Path fading due to atmospheric conditions (usually accompanied by Far-End BER alarm) and low RSL voltage reading
- ❖ Poor transmission line connections (usually accompanied by Far-End BER alarm) and low RSL voltage reading
- ❖ Antenna problems, misalignment or path clearance (usually accompanied by Far-End BER alarm) and low RSL voltage reading
- ❖ Interference
- ❖ Received signal level (RSL) is too strong
- ❖ Far-end radio transmitter circuitry is faulty or Tx Power adjusted incorrectly (too low)
- ❖ Near-end radio receiver circuitry is faulty

Recommended Actions:

An internal loopback test should be performed to verify that errors are occurring over the link:

- ❖ Verify that the near-end radio is set for internal Link Test mode and Latched Error LED (both default settings of rear panel DIP switch positions, as described in Sections 3.12.2 and 3.13.3).
- ❖ Press and hold (for approximately 3 seconds, then release) the Link Test Enable switch on the front panel of one radio (this will take radios out of service). Let this test run for a few minutes.
- ❖ If the ERROR LED illuminates, this is verification that errors are on the link and troubleshooting should continue.
- ❖ Press the Link Test Enable switch to deactivate loopback mode.

Next measure RSL by placing a voltmeter across RSL and GND test points. Compare this voltage to the Factory Test Data Sheet and estimate the RSL in dBm. Compare this to the RSL that was expected using path calculations (see Section 3.3.3). Press and hold the DISPLAY FAR END button and measure the far-end RSL (while continuing to hold the button). Compare this RSL to the Factory Test Data Sheet for the far-end radio and estimate the RSL in dBm. Again, compare this RSL to the expected RSL from the link budget calculations.

If RSL from both ends of the radio are approximately the same as each other, but lower than anticipated for this installation, then the likely cause of the BER alarm(s) is excessive losses between the radios. Excessive loss problems could include the transmission line at either end, all adapters, connectors, the antennas, the antenna alignment as well as the path itself (any obstructions or clearance problems). Antenna alignment, line-of-sight and path clearance should be verified; if this does not improve RSL, all devices between the radios and their antennas at both ends should be checked. Make sure all transmission line, connectors and any other devices are properly rated for operation at the radio's frequency (2.4 or 5.8 GHz).

If only one end has low RSL, this could be caused by low transmit output power from the opposite end radio. Verify that the transmitter output power of the radio opposite to the low RSL receiver has been set in accordance to path calculations, or EIRP restrictions (where applicable). Power adjustment must be performed by professional installation personnel only. The PWR test point can be used and compared with the Factory Test Data Sheet, the front panel recessed potentiometer can be turned clockwise to increase power. If an RF power meter is available, this can be connected to the RF output of the radio for precision measurement. This test will also verify that the radio transmitter is working properly.

If one terminal (or both) has high RSL, this could be caused by a very short path or interference. To verify the possible presence of interference, remove DC power to the radio which is opposite to the one that is reading high RSL. Once power is removed, measure RSL on the remaining radio. If RSL voltage is higher than that which is listed for "Threshold" in the Factory Test Data Sheet, then an interfering signal is present. If interference is suspected, the easiest potential remedy is to swap frequency channels on both sides of the link. See Section 4.2 for details. Swap frequencies on both terminals so that they are the opposite from their original settings (e.g. change A1 into A2 and A2 into A1). Make sure that you change the DIP switch settings to correspond to the channel change. After both ends are changed, reconnect the radios and determine if the BER alarm is still active. If the BER alarm is still active, other frequency channels can be installed, or other interference countermeasures can be tried, in accordance with Section 4.8.

If all path related and data input problems have been pursued and the BER alarm is still active, the problem could be related to a radio failure. While radio failure is typically indicated by more severe alarm conditions, it is possible that one of the radios may be out of specification, and this could be the cause of the BER alarm. A back-to-back test will verify proper radio operation. See Section 4.9 for details. A threshold test on both radios along with a test to verify proper RF output power would be beneficial.



Perform a back-to-back test before returning any radio terminal to the factory for repair. A back-to-back test verifies radio operation. (See Section 4.9).

If the radios successfully pass their back-to-back testing, the problem is likely with the path or the connections between the radio and the antenna or interference. Before reinstalling the radios, be sure to set the output power to the appropriate level for the installation and set rear panel DIP switches to the desired settings for the installation.

4.6.2 MUTE Alarm (AIS)

Function:

This LED indicates an alarm condition for one or both of the following:

- 1) The security address setting for switch 2 on the back of the radio does not match the radio bridge on the other end of the link.
- 2) There is an excessive number of data errors on the 10BaseT connection that the radio will not transmit so it MUTEs the data from being sent.

Possible Causes:

- ❖ Intermittent path fading due to atmospheric conditions (usually accompanied by Far-End RX SYNC or BER alarm) and low RSL voltage reading
- ❖ Also refer to 4.6.3 for other radio path problems.
- ❖ Improper radio switch settings (security address)

Recommended Actions:

- ❖ Verify that both radios in the link have the same security code settings.
- ❖ Correct the 10BaseT connection and/or the corrupt data traffic over the LAN.

4.6.3 RX SYNC (Receiver Synchronization) Alarm

Function:

This LED indicates that the demodulator function is not synchronizing with the intended received signal.

Possible Causes:

- ❖ Severe path fading due to atmospheric conditions (usually accompanied by Far-End RX SYNC or BER alarm) and low RSL voltage reading
- ❖ Poor transmission line connections (usually accompanied by Far-End RX SYNC or BER alarm) and low RSL voltage reading
- ❖ Antenna problems, misalignment, or path clearance (usually accompanied by Far-End RX SYNC or BER alarm) and low RSL voltage reading
- ❖ Improper radio settings (frequency channel, spread code)
- ❖ Interference
- ❖ Far-End radio transmitter circuitry is faulty
- ❖ Near-End radio receiver circuitry is faulty

Recommended Actions:

Check the following at each end of the link:

- ❖ Verify that rear panel filters are opposite channel plans on each end (e.g. one is A1 and other is A2).
- ❖ Verify that rear panel DIP switch settings match each installed filter (see Section 3.12.1).
- ❖ Verify that each radio is set to the same spreading code (see Section 3.12.1).
- ❖ Verify that all connections between radios and antennas are secure and all devices between radios and antennas are rated for the radio frequency band (2.4 or 5.8 GHz).

If RX SYNC alarm continues, follow recommended actions for a BER alarm as described in Section 4.6.1.

4.6.4 FAN Alarm

Function:

This alarm activates only when one or both of the internal fans are faulty.

Possible Cause:

- ❖ Faulty fan inside the radio.

Recommended Actions:

1. Check environmental conditions of the radio. Assure that the ambient temperature at the radio location is within specification of the radio. If not, apply environmental conditioning to radio location or place radio at alternate location where the environmental specifications are met.
2. Visually inspect radio mounting area and ensure that right and left sides of the radio chassis are unobstructed for airflow.
3. Verify that at least one of the internal fans are operational by temporarily covering some of the ventilation holes on the right side of the radio (as you face the front panel) with a thin piece of paper. Slowly pull the paper outwards away from the ventilation holes to determine if the fan is pulling the paper toward the chassis. This can also be checked on the opposite side of the chassis to verify that the fans are pushing air out of the chassis.
4. If at least one fan is working you may wish to postpone repair, as long as the unit is operating without any other errors (the radio is designed to operate with only one fan)
5. If neither fan is working or if typical operating environment is greater than 30°C, it is recommended that the unit be repaired at the soonest opportunity. Return the radio to the factory for repair. See Section 4.5 for details.

4.6.5 RADIO FAIL Alarm

Function:

The RADIO FAIL alarm indicates a known problem with the radio hardware.

Possible Causes:

- ❖ Internal synthesizers are unlocked
- ❖ Internal digital circuits have failed

Recommended Actions:

1. Remove power from the unit.
2. Check to make sure power supply voltages are within specification.
3. Even if the voltages were within specification, reapply power to the unit.
4. If RADIO FAIL alarm clears, place the radio back into service.
5. If RADIO FAIL alarm does not clear, perform a back-to-back test to verify radio operation, as described in Section 4.9.
6. If RADIO FAIL alarm is still active in a back-to-back test, return the radio to the factory for repair (see Section 4.5).

4.6.6 FAR END Alarm

Function:

This LED indicates that there is an alarm condition present on the far-end radio. When the DISPLAY FAR END button is pressed (and held), the status LEDs indicate the alarm conditions of the far-end radio.

Possible Cause:

- ❖ One or more alarm condition(s) exist on the far-end radio

Recommended Actions:

1. Press and hold the DISPLAY FAR END button and observe the LED status.
2. Follow instructions for troubleshooting the far-end radio in accordance to the appropriate LEDs which are in alarm, as described in Section 4.6.1 through 4.6.4.

4.7 Errors in the Data Stream

When the radio is in service, errors in the data stream may occur. This is usually known to the operator by either faulty data indications of downstream equipment, or ERROR LED indications during internal link testing.

During internal test mode link testing, if an error is detected, the ERROR LED will illuminate. In default mode, this lamp will stay lit during link testing if a single error is detected. If Link Test has been performed over a period of time and the ERROR LED does not latch on, the radio link is operating completely error-free.



The ERROR LED only operates in internal test signal link test mode.

It is possible that no alarms appear on the front panel during normal operations, but there are errors present in the data stream. If the BER LED is lit, this indicates rather severe error conditions and it is best to follow the procedures provided in Section 4.6.1. In the case of this type of error, the following information can be helpful to troubleshoot the radio link.

Indications:

- ❖ In Link Test Mode, ERROR LED is illuminated
- ❖ Downstream equipment (Router, Switch, Hub, etc.) indicates errors

Possible Causes:

- ❖ Path fading due to atmospheric conditions
- ❖ Poor transmission line connections
- ❖ Antenna problems, misalignment or path clearance
- ❖ Received signal level (RSL) is too strong
- ❖ Far-End radio transmitter circuitry is faulty
- ❖ Near-End radio receiver circuitry is faulty
- ❖ Interference

Recommended Actions:

1. Verify 10BaseT wiring.
2. Even if the BER alarm LED is unlit but errors continue, follow the instructions described in Section 4.6.1

4.8 Interference Countermeasures

The recommended interference countermeasures available to the *Tsunami* operator are as follows:

1. Short Paths

The single most effective countermeasure against interference is to maintain "short path" length. This may be achieved by dividing long paths into multiple small paths by cascading hops. Intermediate repeaters may be formed using back-to-back *Tsunami* terminals and transmit output power reduced, if required.

By definition, "short path" is defined as a path where fades are extremely rare and signal levels vary by no more than ± 3 dB during fades. This distance will vary with the RF frequency. Typically a "short path" is defined as any path length shorter than 5 miles at 5.8 GHz or 7 miles at 2.4 GHz.

2. Narrow Beam Antennas (high gain)

This is the next most effective countermeasure. Narrow beam antennas ensure that the transmitted power is sent in a single direction and this minimizes the possibility of causing interference inadvertently to other users. Narrow beam antennas also reject off-azimuth signals being received from potential sources of interference and have high gain which boosts desired receive levels and improves the carrier to interference ratio. When selecting narrow beam antennas, it is helpful to know that larger antennas generally outperform smaller antennas. Another important antenna specification is the front-to-back ratio which ensures rejection of unwanted signals from azimuth angles behind the antenna.

3. Frequency Selection

This is another very effective countermeasure. The *Tsunami* radio offers several distinct non-overlapping frequency channel plans (see Sections 3.5 and 4.2) and the radio's RF filter is able to reject interference more than 10 MHz away from the receive frequency. Offset frequencies combined with other countermeasures may enable several receive channels to operate at a single hub site. Because of the limited spreading ratio used, frequency selection is more efficient than code selection for interference rejection when operating multiple *Tsunami* terminals at a single site. Interference can often be overcome by exchanging frequencies of both-ends of the radio link (e.g. change your A1 terminal to an A2 and change the other end from an A2 to an A1). Also, changing channel plans (e.g. from A to B) can be very effective. (See Section 4.2).

4. Antenna Polarization

Cross-polarized antennas can provide approximately 20 to 30 dB discrimination of unwanted signals. The actual discrimination will depend upon the antenna design and any rotation of polarization along the path, for example, due to reflections. Discrimination only exists between two orthogonal polarizations:

- vertical vs. horizontal or
- left-hand circular vs. right-hand circular

There is only 3 dB discrimination between circular and linear (vertical or horizontal) polarization.

Interference can sometimes be overcome by changing antenna polarization at both ends of the link.

5. Spreading Code Selection

There are 4 selectable spreading codes provided for the *Tsunami* radio (See Section 3.12.3). These codes are selected by DIP switches and provide some discrimination against interference from other *Tsunami* transmitters. The discrimination is limited to approximately 3 to 6 dB for radios using the same channel plan. This is the difference between the co-channel C/I when using different codes for the wanted and unwanted signals. When combined with a different frequency channel, the code discrimination improves significantly beyond 3 to 6 dB. See Section 3.12.3 for code selection details.

6. Transmit Power

The maximum level into the receiver is 0 dBm. Above this level, errors may occur in the receive data stream. Transmit output power should be reduced on very short paths to avoid overload.

7. Equipment/Antenna Location

Occasionally, interference is caused by the radio or the antenna being too close to another similar transmitter. For example, at 2.4 GHz, microwave ovens can exhibit interference if mounted near the radio or antenna. Other high powered transmitters may also cause interference. Moving the radio, the antennas, or the interfering equipment can reduce or eliminate interference.



Interference countermeasures rely to some extent on the measurement of the received interference level and frequency. Prior to turning up a new hop, a spectrum analyzer can be used to monitor the spectrum at each end to check for possible interfering signals. See Section 4.8.1 for more details.

4.8.1 Use of a Spectrum Analyzer to Evaluate Potential Interference

Connecting to the antenna and using "peak hold" on a spectrum analyzer, the spectrum between 2.4 GHz and 2.5 GHz (for 2.4 GHz radios) or 5.7 GHz and 5.9 GHz (for 5.8 GHz radios) can be swept and any signals being received at levels above the radio's specified threshold identified. If potential interfering signals are found, then the *Tsunami* frequency plan can be changed to avoid a receive channel which may contain significant interference (see Section 4.2).

For example, interference may be reduced by moving from the A1/A2 plan to the B1/B2 plan or by swapping terminals or RF filters so that A1 becomes A2.



Signals outside the range of 2.4 GHz to 2.5 GHz (for 2.4 GHz radios) and 5.7 GHz to 5.9 GHz (for 5.8 GHz radios) may be ignored: they will not cause interference.

If a spectrum analyzer is not available, the RSL voltage can be used to indicate the background noise and interference level within the receiver RF filter band when the far-end transmitter is turned off. With the far-end radio turned off, if an RSL voltage level above the radio's threshold level is measured, there is potentially interference in this frequency channel.



When using a spectrum analyzer for determining the presence of interference, very narrow resolution bandwidth settings must be used to detect signals down to the radio's threshold (approximately -87 to -95 dBm, depending on radio type).

4.9 Back-to-Back Testing

Back-to-back testing, as shown in Figure 4-1, is an ideal method of testing the *Tsunami* radios. This testing eliminates link problems caused by auxiliary equipment, installation, or the radio path and isolates potential radio hardware problems. Back-to-back testing must be performed with both radios at the same location. The following test equipment is required:

- ❖ DC power source capable of supplying approximately 90 Watts (total) to the radios (or two AC adapters)
- ❖ One low-loss coaxial cable, N-to-N male
- ❖ One (or more) coaxial in-line calibrated fixed attenuators, 40 to 80 dB total attenuation

The following test equipment may also be useful to perform further testing of the *Tsunami* radio:

- ❖ BER tester
- ❖ Variable (60 dB range or more) RF attenuator (rated for the proper frequency, 2.4 or 5.8 GHz)
- ❖ RF power meter



Back-to-back testing must be performed to verify a radio problem before returning any radio to the factory for repair.

When the equipment is connected as shown in Figure 4-1, both *Tsunami* radios should have no alarm conditions. When Link Test is enabled at either end, no errors should be registered by the ERROR indication. If these conditions have been met, then it is likely that the *Tsunami* radio is operating in accordance to specifications. If errors or alarms occur during this test, verify that all DIP switch settings are properly set. If alarms or errors are still present, the radio is likely to be faulty.

If further troubleshooting is required, a variable RF attenuator can be inserted between the radios to fade down the path to determine that the threshold specification is being met. The threshold tests can be run in both directions to isolate the radio problem (if any). More information testing is provided in Section 4.10. An RF power meter can be used to individually test each radio's output power.

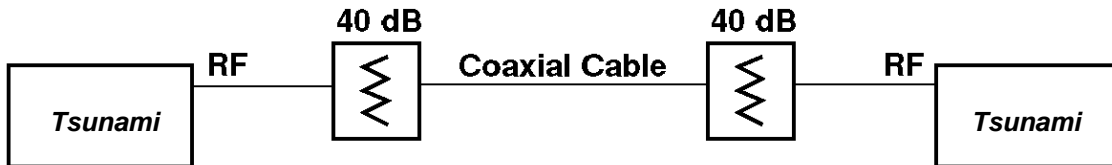

Figure 4-1: Back-to-Back Test Configuration



The Tsunami radios will be damaged if appropriate attenuation is not supplied between radios. You must provide a minimum of 40 dB and no more than 80 dB attenuation between the two radios.

4.10 LINK Testing

Link testing is the preferred way to evaluate a radio link's performance. It can be performed from end-to-end or in link test mode (which tests both directions of the radio path). Figure 4-2 illustrates a typical test configuration (which may include the radio's path instead of in-line attenuators). Figure 4-2 illustrates a typical test configuration for end-to-end testing.

When performing testing, make sure of the following:

- Disconnect all 10BaseT inputs and outputs to both radios.
- Verify all DIP switch settings.

Link testing may be performed on the bench, with two terminals back to back, or over the radio path. Also, it may be performed from end-to-end (which requires two 10BaseT test sets over a link, the far-end unit slaved to the near-end unit's clock) or in loopback mode, as described in Section 4.9.

If link testing indicates an unacceptable level of errors, follow the instructions in Section 4.6.1. or perform a back-to-back test as described in Section 4.9.

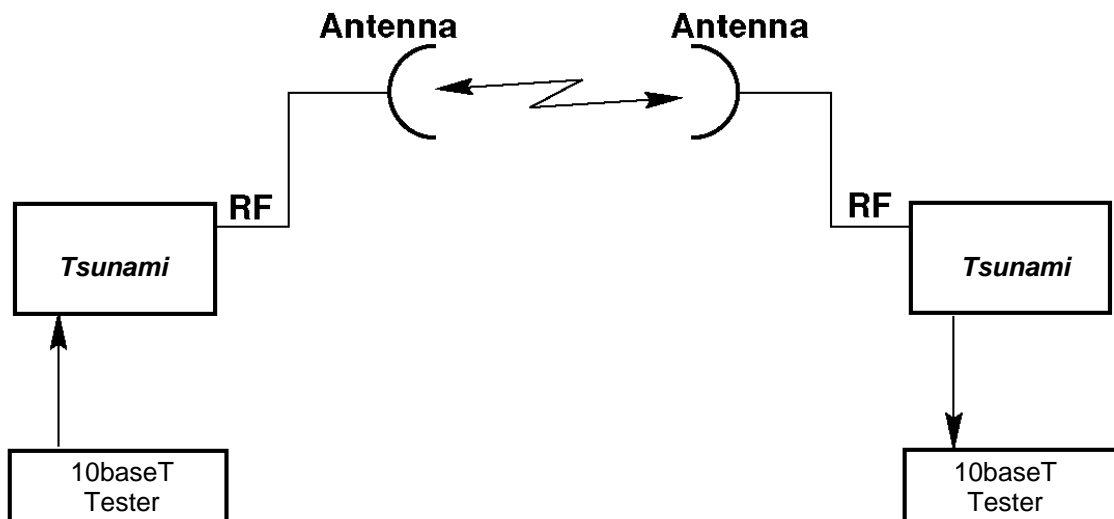

Figure 4-2: End-to-End Test Configuration

Your Notes on the *Tsunami* Radio

5. Appendices

Appendix A - Digital Interface Specifications

1. General Characteristics

10baseT (IEEE 802.3) Fully compliant to Ethernet V.2

2. Specifications

Transmission Medium	UTP
Signaling Technique	Manchester
Topology	Star
LAN Table	10,000 addresses (automatic learning and aging)
Filtering	15,000 pps
Data Rate	Up to 10 Mbps (limited to throughput of particular radio model)
Delay	1 frame
Buffer	256 frames
Frame size (Maximum)	Total size cannot exceed 1518 bytes (including: VPN, VLAN frames) -Use the MTU command to limit data portion of Ethernet frame to 1496 bytes- Note: VPN/VLAN tagging is NOT supported within the 10BaseT standard, but may be attempted via router and/or manageable switch with this product -Use the MTU command to limit the data portion of Ethernet frame to 1496 bytes-
Duplex	Full or half

Table A-1: Interconnection Specification

Appendix B - Rear Panel DIP Switches

The *Tsunami* radio has three separate eight-segment rear panel DIP switches, labeled SW1, SW2 and SW3. Upon shipment from the factory, these switches are set for factory default configuration, which is all switches down (in the “zero” position), except for SW3 positions 5 through 8, which are set to match the installed rear panel RF filter assembly (which determines the frequency channel for transmit and receive, such as A1, A2, B1, B2, etc.). The tables in this section provide a quick reference for the DIP switch functions and their settings.



DIP switch settings are noted by their position, either up (1), or down (0), not by on/off as may be printed on the DIP switch assembly.

Shaded switch positions are factory default

	1	2	3	4	5	6	7	8
SW1	1							
	0	0	0	0	0	0	0	0

1	Bridge Operation
1	Full Duplex
0	Half Duplex

2	Bridge Filter
1	Disabled
0	Enabled

4	Radio Link Test
1	Disable (Flash)
0	Enable Latch

5	Receive AIS injected
1	Disable
0	Mute

Diagnostic port	7
Craft	1
TBOS (Open LYNX)	0

AUX Data Port	8
Enabled (Clear	1
Bridged (TBOS)	0

	1	2	3	4	5	6	7	8
SW2	1							
	0	0	0	0	0	0	0	0

1-8	Security Address
0	Binary setting from
255	0 to 255 (8 bits)

	1	2	3	4	5	6	7	8
SW3	1							
	0	0	0	0	0	0	0	0

1	2	Spreading Code
0	0	Code 1
0	1	Code 2
1	0	Code 3
1	1	Code 4

2.4Ghz 2Mb No T1/E1

Frequency	Xmitter	Rcvr	7 LSB	8
A1	2410	2453	0	0
A2	2453	2410	0	1
B1	2430	2473	1	0
B2	2473	2430	1	1

Table B-1: (Updated-Cont.) Tsunami 2.4 Ghz (~2Mbps) Switch Settings (discontinued model)

Shaded switch positions are factory default

SW1

	1	2	3	4	5	6	7	8
1								
0	0	0		0	0		0	0

1	Bridge Operation
1	Full Duplex
0	Half Duplex

2	Bridge Filter
1	Disabled
0	Enabled

4	Radio Link Test
1	Disable (Flash)
0	Enable Latch

5	Receive AIS injected
1	Disable
0	Mute

Diagnostic port	7
Craft	1
TBOS (Open LYNX)	0

AUX Data Port	8
Enabled (Clear)	1
Bridged (TBOS)	0

SW2

	1	2	3	4	5	6	7	8
1								
0	0	0	0	0	0	0	0	0

1-8	Security Address
0	Binary setting from
255	0 to 255 (8 bits)

SW3

	1	2	3	4	5	6	7	8
1								
0	0	0	0	0	0	0	0	0

1	2	Spreading Code
0	0	Code 1
0	1	Code 2
1	0	Code 3
1	1	Code 4

0	0	Code 1
0	1	Code 2
1	0	Code 3
1	1	Code 4

5.8Ghz ~4Mb No T1/E1

Frequency	Xmitter	Rcvr	7	8
A1	5741	5803	0	0
A2	5803	5741	0	1
B1	5772	5834	1	0
B2	5834	5772	1	1

Table B-2: (Updated-Cont.) Tsunami 5.8 Ghz (~4Mbps) Switch Settings (discontinued model)

Shaded switch positions are factory default

	1	2	3	4	5	6	7	8
SW1	1							
	0	0	0	0	0	0	0	0

1	Bridge Operation
1	Full Duplex
0	Half Duplex

2	Bridge Filter
1	Disabled
0	Enabled

3	CH 1 AMI/B8ZS	T1 Only
1	AMI	
0	B8ZS	

4	Radio Link Test
1	Disable (Flash)
0	Enable Latch

5	Receive AIS injected
1	Disable
0	Mute

T1 Only	6	CH 2 AMI/B8ZS
	1	AMI
	0	B8ZS

Diagnostic port	7
Craft	1
TBOS (Open LYNX)	0

AUX Data Port	8
Enabled (Clear)	1
Bridged (TBOS)	0

	1	2	3	4	5	6	7	8
SW2	1							
	0	0	0	0	0	0	0	0

1-8	Security Address
0	Binary setting from
255	0 to 255 (8 bits)

	1	2	3	4	5	6	7	8
SW3	1							
	0	0	0	0	0	0	0	0

1	2	Line Build Out
0	0	0-133 feet
0	1	134-266 feet
1	0	267-399 feet
1	1	399-533 feet

Position 1&2 are spare for E1

3	CH1 T1/E1 Disable
1	Disabled
0	Enabled

4	CH 2 T1/E1 Disable
1	Disable
0	Enable

Spare for 1xT1

Position 5 is a spare

Table B-3: (Updated) Tsunami 2.4/5.8 Ghz (~8/12Mbps) Switch Settings

5.8GHz 8Mb 1xT1/E1	Frequency	Xmiter	Rcvr	6 MSB	7 LSB	8
	A1	5735	5800	0	0	0
	A2	5800	5735	0	0	1
	A1	5735	5800	1	1	0
	A2	5800	5735	1	1	1
	B1	5755	5820	0	0	0
	B2	5820	5755	0	0	1
	C1	5775	5840	1	1	0
	C2	5840	5775	1	1	1
5.8GHz 12Mb 2xT1/E1	Frequency	Xmiter	Rcvr	6 MSB	7 LSB	8
	A1	5741	5803	no-care	0	0
	A2	5803	5741	no-care	0	1
	A1	5741	5803	1	1	0
	A2	5803	5741	1	1	1
	B1	5772	5834	0	0	0
	B2	5834	5772	0	0	1
2.4Ghz 12Mb 2xT1	Frequency	Xmiter	Rcvr	6 MSB	7 LSB	8
	A1	2411	2461	0	0	0
	A2	2461	2411	0	0	1

Table B-3: (Updated-Cont.) Tsunami 2.4/5.8 Ghz (~8/12Mbps) Switch Settings



Byte	Point	Bit	Type	Scan Point Definition	Control Point Definition	Notes
1	1	7	S	Model ID MSB		1101 = 2.4 GHz 2 Mbps (Model 31150)
	2	6	S	Model ID LSB+2		1110 = 5.8 GHz 4 Mbps (Model 31170)
	3	5	S	Model ID LSB+1		???? = 5.8 GHz 8 Mbps (Model 31180)
	4	4	S	Model ID LSB		1111 = 5.8 GHz 12 Mbps (Model 31145)
	5	3	N/A	Future Use		
	6	2	S	Channel Plan ID MSB		SW3 pos 6 00=A, 01=B
	7	1	S	Channel Plan ID LSB		SW3 pos 7
	8	0	S	Channel Plan Tx High/Low		SW3 pos 8 (1 = Tx High, i.e. A2, B2, C2)
2	9	7	A	Radio Fail Alarm		Equal to F/P alarm
	10	6	A	Mute/AIS Alarm		Equal to F/P alarm
	11	5	A	Fan Alarm		Equal to F/P alarm
	12	4	A	Rx Sync Alarm		Equal to F/P alarm
	13	3	A	Loopback Error Alarm		Equal to F/P alarm
	14	2	A	BER Alarm		Equal to F/P alarm
	15	1	A	Far-End Alarm		Equal to F/P alarm
	16	0	A	Telemetry Down Alarm		Equal to F/P alarm
3	17	7	A	Collisions		Equal to F/P alarm
	18	6	A	Ethernet Link		0: normal 1:no link on 10baseT
	19	5	A	CH1 Data Loss		Equal to F/P alarm
	20	4	A	CH2 Data Loss		Equal to F/P alarm, where applicable
	21	3	S	Half Duplex Enabled		SW1 pos 1 0:Full -Duplex 1:Half-Duplex 10baseT
	22	2	S	Filter Disabled		SW1 pos 2
	23	1	S	CH1-T1/E1 Disable		SW3 pos 3
	24	0	S	CH2-T1/E1 Disable		SW3 pos 4
4	25	7	A	Security Address Mismatch		Internal Alarm Indication of codes set with SW2
	26	6	S	Test Latch Disabled		SW1 pos 4 (0 = Latched, 1 = Momentary)
	27	5	S/C	Ethernet Link Test Enabled		0:normal 1:channel in loopback
	28	4	S/C	Channel 1 Loopback Enabled		0:normal 1:channel in loopback
	29	3	S/C	Channel 2 Loopback Enabled		0:normal 1:channel in loopback
	30	2				
	31	1	S	Receive AIS Injection		SW1 pos 5 0:enable 1:disable
	32	0	S	Aux Port Enabled		SW1 pos 8 0:Bridge 1:Clear Aux Data
5	33	7	S	CH1 AMI/B8ZS (T1)		SW1 pos 3 0=AMI, 1=B8ZS
	34	6	S	CH2 AMI/B8ZS (T1)		SW1 pos 6 0=AMI, 1=B8ZS
	35	5	S	Line Build Out (T1) MSB		SW3 pos 1 (msb) & 2 (lsb): 00=0-133ft;
	36	4	S	Line Build Out (T1) LSB		
	37	3	S	Far-End Address Invalid		1=Address>08
	38	2	S	Far-End Address MSB		000=01, 001=02, 010=03, Bit2 (msb) Bit0 (lsb)
	39	1	S	Far-End Address LSB+1		011=04, 100=05, 101=06,
	40	0	S	Far-End Address LSB		110=07, 111=08
6	41	7	S	Near-End RSL MSB		RSL APPROX.=BINARY VALUE (integer) x 0.04 V Note The 8-bit binary value (0-255) represents RSL values between -50 dBm and threshold. Radio paths with higher RSL values will read approximately five (5) to ten (10) VDC on the radio's front panel test point but be limited to a maximum binary reading of 255 which represents 5 VDC.
	42	6	S	Near-End RSL MSB-1		
	43	5	S	Near-End RSL MSB-2		
	44	4	S	Near-End RSL MSB-3		
	45	3	S	Near-End RSL MSB-4		
	46	2	S	Near-End RSL MSB-5		
	47	1	S	Near-End RSL MSB-6		
	48	0	S	Near-End RSL MSB-7		
7	49	7	S	Near-End Tx Power MSB		TxPWR APPROX.=BINARY VALUE (integer) x 0.02 Volts 8-bit byte derives voltage or dBm
	50	6	S	Near-End Tx Power MSB-1		
	51	5	S	Near-End Tx Power MSB-2		
	52	4	S	Near-End Tx Power MSB-3		
	53	3	S	Near-End Tx Power MSB-4		
	54	2	S	Near-End Tx Power MSB-5		
	55	1	S	Near-End Tx Power MSB-6		
	56	0	S	Near-End Tx Power MSB-7		
8	57	7	A	Both Fans Bad		Only applies if Point 11=1
	58	6	A	Tx Synth Unlock		Only applies if Point 9=1
	59	5	A	Rx Synth Unlock		Only applies if Point 9=1
	60	4	A	Input Line Driver CH1		Only applies if Point 9=1
	61	3	A	Input Line Driver CH2		Only applies if Point 9=1
	62	2	N/A	Future Use		Key: A = Alarm S = Status C = Control
	63	1	N/A	Future Use		
	64	0	N/A	Future Use		

Table B-4: Tsunami TBOS Bit Map

Appendix C – Networking Q&As

Q: What is Ethernet?

A: Ethernet is a type of network cabling and signaling specifications (OSI Model layers 1 [physical] and 2 [data link]) originally developed by Xerox in the late 1970. The IEEE's (Institute of Electrical and Electronics Engineers) used Ethernet Version 2 as the basis for the 802.3 CSMA/CD network standard.

Q: What is an 802.3 network?

A: That's IEEE-ish for Ethernet. Note: IPX is handled through 802.2 standard.

Q: What is CSMA/CD?

A: CSMA/CD is the media access control mechanism used by Ethernet and 802.3 networks; in other words, it determines how a packet of data is placed on the wire. CSMA/CD stands for "Carrier Sense Multiple Access, with Collision Detection". Before an Ethernet device puts a packet "on the wire", it listens to find if another device is already transmitting. Once the device finds the wire is clear, it starts sending the packet while also listening to hear if another device started sending at the same time (which is called a collision). Refer to the Q&A on collisions for more info about this phenomena.

Q: What is an OSI Model?

A: The Open Systems Interconnect (OSI) reference model is the ISO (International Standards Organization) structure for the "ideal" network architecture. This Model outlines seven areas, or layers, for the network. These layers are (from highest to lowest):

LAYER

- 7) Applications: Where the user applications software lies. Such issues as file access and transfer (FTP), virtual terminal emulation, Internet connections (HTTP), inter-process communication and the like are handled here.
- 6) Presentation: Differences in data representation are dealt with at this level. For example, UNIX-style line endings (CR only) might be converted to MS-DOS style (CRLF), or EBCDIC to ASCII character sets.
- 5) Session: Communications between applications across a network is controlled at the session layer. Testing for out-of-sequence packets and handling two-way communication are handled here.
- 4) Transport: Makes sure the lower three layers are doing their job correctly, and provides a transparent, logical data stream between the end user and the network service s/he is using. This is the lower layer that provides local user services.
- 3) Network: This layer makes certain that a packet sent from one device to another actually gets there in a reasonable period of time. Routing and flow control are performed here. This is the lowest layer of the OSI model that can remain ignorant of the physical network.

- 2) Data Link: This layer deals with getting data packets on and off the physical layer, error detection and correction and retransmission. This layer is generally broken into two sub-layers: The LLC (Logical Link Control) on the upper half, which does the error checking, and the MAC (Medium Access Control) on the lower half, which deals with getting the data on and off the physical layer (wire, fiber and Tsunami Wireless Bridges).
- 1) Physical: The nuts and bolts layer. Here is where the cable, fiber, radio, connector and signaling specifications are defined.

Q: What does an Ethernet packet look like?

A. See the information below, as described in the National Databook. The Ethernet packet preamble is normally generated by the chipset. Software is responsible for the destination address, source address, type, and data. The chips normally will append the frame check sequence.

62 bits	Preamble - A series of alternating 1's and 0's used by the Ethernet receiver to acquire bit synchronization.
2 bits	Start Of Frame Delimiter - Two consecutive 1 bits used to acquire byte alignment.
6 bytes	Destination Ethernet Address - Address of the intended receiver. The broadcast address is all 1's.
6 bytes	Source Ethernet Address - The unique Ethernet address of the sending station.
2 bytes	Length or Type field - For IEEE 802.3 this is the number of bytes of data.
46 bytes to 1500 bytes	Data - Short packets must be padded to 46 bytes.
4 bytes	Frame Check Sequence(CRC) - The FCS is a 32 bit CRC calculated using the AUTODIN II polynomial.

The shortest packet is: $6 + 6 + 2 + 46 = 60$ bytes The longest packet is: $6 + 6 + 2 + 1500 = 1514$ bytes

Q: What is a MAC address?

A: It is the unique hexadecimal (numbering base 16) serial number assigned to each Ethernet network device to identify it on the network.. With Ethernet devices (as with most other network types), this address is permanently set at the time of manufacturer, though it can usually be changed through software (though this is generally a Very Bad Thing to do).

Q: Why must the MAC address to be unique?

A: Each communicating end device (not bridges) has a unique MAC address, so that it will be able to exclusively grab packets off the network meant for it. If MAC addresses are not unique, there is no way to distinguish between two devices. Devices on the network watch network traffic and look for their own MAC address in each packet to determine whether they should decode it or not. Special circumstances exist for broadcasting to every device.

Q: Is there a special numbering scheme for MAC addresses?

A: The MAC addresses are exactly 6 bytes in length, and are usually written in hexadecimal as 12:34:56:78:90:AB (the colons may be omitted, but generally make the address more readable). Each manufacturer of Ethernet devices applies for a certain range of MAC addresses they can use. The first three bytes of the address determine the manufacturer. RFC-1700 (available via FTP) lists some of the manufacturer-assigned MAC addresses. A more up-to-date listing of vendor MAC address assignments is available on ftp.lcs.mit.edu in pub/map/Ethernet-codes.

Q: What does CRC mean?

A: Cyclical Redundancy Check - A method of detecting errors in a message by performing a mathematical calculation on the bits in the message and then sending the results of the calculation along with the message. The receiving work-station performs the same calculation on the message data as it receives it and then checks the results against those transmitted at the end of the message. If the results don't match, the receiving end asks the sending end to send again.

Q: What do 10Base5, 10/100BaseT, 10Base2, etc mean?

A: These are the IEEE names for the different physical types of Ethernet. The "10" stands for maximum signaling speed: 10MHz. "Base" means Baseband. 10/100BaseT, where the T means twisted pair, and 10/100BaseF where the F means fiber (see the following Q&A for specifics). This actually comes from the IEEE committee number for that media. The "100" stands for maximum signaling speed: 100MHz.

In actual practice:

10Base2 is a maximum of 10MHz Ethernet running over thin, 50 Ohm baseband coaxial cable. 10Base2 is also commonly referred to as thin-Ethernet or Cheapernet. 10Base5 is 10MHz Ethernet running over standard (thick) 50 Ohm baseband coaxial cabling. 10/100BaseF is Ethernet running over fiber-optic cabling. 10/100BaseT is Ethernet running over unshielded, twisted-pair cabling.

Q: What is UTP?

A: Twisted pair cables. UTP is for Unshielded, Twisted Pair, while STP is for Shielded, Twisted Pair. UTP is what's typically installed by phone companies (though this is often not of high enough quality for high-speed network use) and is what 10/100BaseT Ethernet runs over. UTP is graded according to its data carrying ability (e.g., Level 3, Level 4, Level 5). 10BaseT Ethernet requires at least Level 3 cable. Many sites now install only Level-5 UTP (CATegory 5), even though level 4 is more than sufficient for 10BaseT, because of the greater likelihood that emerging high-speed standards will require cable with better bandwidth capabilities. Fast Ethernet (100BaseT) must use CAT5!

Q: Are there any restrictions on how Ethernet is cabled?

A: Yes, there are many, and they vary according to the media used. First of all, there are distance limitations: 10/100BaseT generally accepted to have a maximum run of 100-150M, but is really based on signal loss in dB's (11.5db maximum loss source to destination). Then there are limitations on the number of repeaters and cable segments allowed between any two stations on the network.

The rule is, any possible path between two network devices on an unbridged/unrouted network cannot pass through more than 4 repeaters or hubs, nor more than 3 populated cable segments. 10/100BaseT and 10/100BaseF are star-wired, so there is no minimum distance requirement between devices, since devices cannot be connected serially. You can install up to the Ethernet maximum of 1024 stations per network with both 10/100BaseT and 10/100BaseF.

Q: When should I choose 10/100BaseT, 10/100BaseF (or others)?

A: The specific environment and application must be considered when selecting your media type. However, there are some general rules-of-thumb that you can consider:

Avoid using copper between buildings. The electrical disturbances caused by lightning, as well as naturally occurring differences in ground potential over distance, can very quickly and easily cause considerable damage to equipment and people. The use of fiber-optic cabling between buildings eliminates network cabling as a safety risk. There are also various wireless media available for inter-building links, such as laser, spread-spectrum RF and microwave.

10/100BaseT is the most flexible topology for LANs, and is generally the best choice for most network installations. 10/100BaseT hubs, or multi-hub concentrators, are typically installed in a central location to the user community, and inexpensive UTP cabling is run to each network device (which may be 100m, or 330ft, from the hub). The signaling technology is very reliable, even in somewhat noisy environments, and 10/100BaseT hubs will usually detect many network error conditions and automatically shut-down the offending port(s) without affecting the rest of the network (unless, of course, the offending port was your server, shared printer, or router to the rest of the world).

10/100BaseF, and its predecessor, FOIRL, are the only recommended topologies for inter-building links. However, they need not be limited to this role. 10/100BaseF can also be run to the desktop, though the cost is prohibitively high in all but the most specialized environments (generally, extremely noisy manufacturing facilities, or very security-conscious installations). More commonly, FOIRL (and now, 10/100BaseF) is used inside buildings and long distance wireless connections to form backbone networks.

Q: Is there an official "standard" punch down scheme for 10BaseT?

A: Get a copy of EIA/TIA-568, it covers all of that sort of stuff: horizontal, vertical, connectors, patch cords, cross-connects, etc.

Q: Is it safe to run Unshield Twisted Pair next to power cable?

A: According to EIA/TIA-569, the standard wiring practices for running data cabling and companion to the above referenced EIA/TIA-568, you should not run data cable parallel to power cables. However, in reality, this should not be a problem with networks such as 10/100BaseT. 10/100BaseT uses differential signaling to pick the data signals off the wire. Since any interference from nearby power lines will usually affect all pairs equally, anything that is not canceled-out by the twists in the UTP should be ignored by the receiving network interface.

Q: Can I connect the 10/100BaseT interface of two devices directly together, without using a hub?

A: Yes, but not more than 2 devices, and you also need a special jumper cable between the two 10/100BaseT ports:

```
RJ45 pin          RJ45 pin
=====          =====
1 <--[TX+]-----[RX+]--> 3
2 <--[TX-]-----[RX-]--> 6
3 <--[RX+]-----[TX+]--> 1
6 <--[RX-]-----[TX-]--> 2
```

Q: What is a "segment"?

A: A piece of network wire bounded by bridges, routers, repeaters or terminators.

Q: What is a "subnet"?

A: Another overloaded term. It can mean, depending on the usage, a segment, a set of machines grouped together by a specific protocol feature (note that these machines do not have to be on the same segment, but they could be) or a big nylon thing used to capture enemy subs.

Q: What is a repeater?

A: A repeater acts on a purely electrical level to connect to segments. All it does is amplify and reshape (and, depending on the type, possibly retime) the analog waveform to extend network segment distances. It does not know anything about addresses or forwarding, thus it cannot be used to reduce traffic as a bridge can in the example above.

Q: What is a "switch"?

A: A switch connects Ethernet packets at the MAC address level (ISO Level 2, like Bridges). It divides a local area network (LAN) into multiple, separate *segments*. Each segment has

it's own full Ethernet (or Fast Ethernet) bandwidth that does not compete with other segments for network transmission. The switch acts as a high-speed selective bridge between the individual segments. The switch, without interfering with any other segments, automatically forwards traffic that needs to go from one segment to another and blocks traffic that does not need to be sent through another segment. Always use a switch to maintain a high level of network operation over the choice of a hub. Switches come in both managed and unmanaged versions.

Q: What is a "hub?"

A: A hub is a common wiring point for star-topology networks, and is a common synonym for concentrator (though the latter generally has additional features or capabilities). 10/100BaseT and 10/100BaseF Ethernet and many proprietary network topologies use hubs to connect multiple cable runs in a star-wired network topology into a single network. Hubs have multiple ports to attach the different cable runs. Some hubs (such as 10/100BaseT) include electronics to regenerate and retime the signal between each hub port. Use a hub only when the network connections are very few, a switch is always a better choice for multiple network connections.

Q: What is a bridge?

A: A bridge will connect to distinct segments and transmit traffic between them. This allows you to extend the maximum size of the network while still not breaking the maximum wire length, attached device count, or number of repeaters for a network segment.

Q: What does a "learning bridge"?

A: A learning bridge monitors MAC (OSI layer 2) addresses on both sides of its connection and attempts to learn which addresses are on which side. It can then decide when it receives a packet whether it should cross the bridge or stay local (some packets may not need to cross the bridge because the source and destination addresses are both on one side). If the bridge receives a packet that it doesn't know the addresses of, it will forward it by default. IEEE's standard for a learning bridge is 802.1D.

Q: Is there a maximum number of bridges allowed on a network?

A: Per IEEE 802.1 (d), the maximum number of concatenated bridges in a bridged LAN is 7. This number is rather arbitrary, however, and is based on simulations of application performance with expected bridge delays.

In addition, the number assumes that all bridges are LOCAL (no remote WAN connections), and that the default Hold Time of 1 second is in place (this is the time after which a bridge will discard a frame it is holding). This prevents extra-late frame delivery. (i.e, a frame should never be delivered more than ~7 seconds after it is sent). The rule of thumb for wireless WAN bridged LANs is to limit the number of hops to 4.

Q: What is a router?

A: Routers work much like bridges, but they pay attention to the upper network layer protocols (OSI layer 3) rather than data link layer (OSI layer 2) protocols. A router will decide whether to forward a packet by looking at the protocol level addresses (for instance, TCP/IP addresses) rather than the MAC address. Because routers work at layer

3 of the OSI stack, it is possible for them to transfer packets between different media types (i.e., leased lines, Ethernet, token ring, X.25, Frame Relay and FDDI). Many routers can also function as bridges.

Q: So should I use a router or a bridge?

A: There is no absolute answer to this. Your network layout, type and amount of hosts and traffic, and other issues (both technical and non-technical) must be considered. Routing would always be preferable to bridging except that routers are slower and usually more expensive (due to the amount of processing required to look inside the physical packet and determine which interface that packet needs to get sent out), and that many applications use non-routable protocols.

Rules of thumb:

Bridges are usually good choices for small networks with few, if any, slow redundant links between destinations or for connecting distant LANs. Further, bridges may be your only choice for certain protocols, unless you have the means to encapsulate (tunnel) the un-routable protocol inside a routable protocol.

Routers are usually much better choices for larger networks, particularly where you want to have a relatively clean WAN backbone. Routers are better at protecting against protocol errors (such as broadcast storms) and bandwidth utilization. Since routers look deeper inside the data packet, they can also make forwarding decisions based on the upper-layer protocols.

Occasionally, a combination of the two devices are the best way to go. Bridges can be used to segment small networks that are geographically close to each other, between each other and the router to the rest of the WAN.

Q: Are there problems mixing Bridging & Routing?

A: Only if you plan on having bridged links in parallel with routed links. You need to be very careful about running bridges providing links in parallel to a router. Bridges may forward broadcast requests which will confuse the router there are lots of protocols you may not think of filtering (e.g. ARP, Apple ARP over 802.3 etc. etc.). Also, DECnet routers have the same MAC address on all ports. This will probably cause the bridge to think it is seeing an Ethernet loop.

Q: Who makes the fastest/easiest/most advanced bridges or routers?

A: The IETF runs bench marks on a wide selection of wired/fiber bridges and routers. Network Computing runs bench marks for wireless routers (point-to-multipoint) and bridges (point-to-point).

Q: What does "IPG" mean?

A: The InterPacket Gap (more properly referred to as the InterFrame Gap, or IFG) is an enforced quiet time of 9.6 us between transmitted Ethernet frames.

Q: What means "promiscuous mode"?

A: Promiscuous mode is a condition where the network interface controller will pass all Ethernet frames, regardless of destination address, up to the higher level network layers. Normally the network controller will only pass up frames that have that device's destination address. However, when put in promiscuous mode, all frames are passed on up the network stack regardless of destination address. Promiscuous mode is usually used by network monitoring tools and transparent bridges.

Q: What is a collision?

A: A condition where two devices detect that the network is idle and end up trying to send packets at exactly the same time (within 1 round-trip delay). Since only one device can transmit at a time, both devices must back off and attempt to retransmit again.

The retransmission algorithm requires each device to wait a random amount of time, so the two are very likely to retry at different times, and thus the second one will sense that the network is busy and wait until the packet is finished. If the two devices retry at the same time (or almost the same time) they will collide again, and the process repeats until either the packet finally makes it onto the network without collisions, or 16 consecutive collision occur and the packet is aborted.

Q: What causes a collision?

A: See above. Ethernet is a CSMA/CD (Carrier Sense Multiple Access/ Collision Detect) system. It is possible to not sense carrier from a previous device and attempt to transmit anyway, or to have two devices attempt to transmit at the same time; in either case a collision results. Ethernet is particularly susceptible to performance loss from such problems when people ignore the "rules" for wiring Ethernet.

Q: How many collisions are too many?

A: This depends on your application and protocol. In many cases, collision rates of 50% will not cause a large decrease in perceived throughput. If your network is slowing down and you notice the percentage of collisions is on the high side, you may want try segmenting your network with either a bridge or router to see if performance improves.

Q: How do I reduce the number of collisions?

A: Disconnect devices from the network. Seriously, you need to cut- down on the number of devices on the network segment to affect the collision rate. This is usually accomplished by splitting the segment into two pieces and putting a bridge or router in between them.

Q: What is a late collision?

A: A late collision occurs when two devices transmit at the same time, but due to cabling errors (most commonly, excessive network segment length or repeaters between devices) neither detects a collision. The reason this happens is because the time to propagate the signal from one end of the network to another is longer than the time to put the entire packet on the network, so the two devices that cause the late collision never see that the other's sending until after it puts the entire packet on the network. Late collisions are detected by the transmitter after the first "slot time" of 64 byte times. They are only detected during transmissions of packets longer than 64 bytes. It's detection is exactly the same as for a normal collision; it just happens "too late."

Typical causes of late collisions are segment cable lengths in excess of the maximum permitted for the cable type, faulty connectors or improper cabling, excessive numbers of repeaters between network devices, and defective Ethernet transceivers or controllers.

Another negative concerning late collisions is that they occur for small packets also, but cannot be detected by the transmitter. A network suffering a measurable rate of late collisions (on large packets) is also suffering lost small packets. The higher protocols do not cope well with such losses. Well, they cope, but at much reduced speed. A 1% packet loss is enough to reduce the speed of NFS by 90% with the default retransmission timers. That's a 10 times increase of the problem!

Finally, Ethernet controllers do not retransmit packets lost to late collisions.

Q: What is a jam?

A: When a workstation receives a collision, and it is transmitting, it puts out a jam so all other stations will see the collision also. When a repeater detects a collision on one port, it puts out a jam on all other ports, causing a collision to occur on those lines that are transmitting, and causing any non-transmitting stations to wait to transmit.

Q: What is a broadcast storm?

A: An overloaded term that describes an overloaded protocol. Basically it describes a condition where devices on the network are generating traffic that by its nature causes the generation of even more traffic. The inevitable result is a huge degradation of performance or complete loss of the network as the devices continue to generate more and more traffic. This can be related to the physical transmission or to very high level protocols.

Q: How do I recognize a broadcast storm?

A: That depends on what level it is occurring. Basically you have to be aware of the potential for it beforehand and be looking for it, because in a true broadcast storm you will probably be unable to access the network. This can change dramatically for a higher level protocol. NFS contention can result in a dramatic DROP in Ethernet traffic, yet no one will have access to resources.

Q: How can I prevent a broadcast storm?

A: Avoid protocols that are prone to it. Route (with routers) or Bridge (with wired/wireless bridges) when it is practical.

Q: What is *high* traffic on an Ethernet? 5%? 20%? 90%?

A: High traffic is when things start slowing down to the point they are no longer acceptable. There is not set percentage point, in other words. Usually start paying attention when it gets over 40-50%.

Q: Why do I see different throughput speeds?

A: Bridges (such as Tsunami) are ISO Layer 2 Data Link Layer (use MAC address for filtering) devices where they provide their full stated throughput. At level 2 (bridges) or 3 (routers) where hardware plays the major part, the most common tester is the SmartBits 200 product from NetCom Systems. At Application Layer 7, you will see less than 40% throughput from the maximum capacity measured w/SmartBits due to the increased protocol/software overhead at that level. Layer 7 can be tested with software such as Ganymede's Chariot or Qcheck product.

As an example: testing copper CAT5 cable with SmartBits will test 100% throughput (let's say you can send/rcv a full 10Mbps). At Layer 7 you will be transferring data at the 10Mbps rate, but only 4Mbps of user data will transfer (Ethernet has a high overhead of bytes added to each data packet each time you go up a layer). The advantage is the more complex overhead makes the data virtually resilient to corruption and minor errors (i.e. collisions), it's easy to reroute and can use inexpensive plug/play devices like hubs/switches instead of multiplexers as used in the telco industry (i.e. LYNX T1 radios)

Western Multiplex tests at Layer 2 where bridges are defined. At layer 7 (Application Layer), you will see less than 40% or more depending on the other traffic that may be on the LAN as this layer is more dependent on the type of data being sent (it does not matter if it's wire, fiber or any Ethernet bridge -wired or wireless). Another way to look at it: the model 31145 12Mbps (10Mbps 10BaseT+T1/E1 wayside) bridge will test the same as a piece of CAT5 Ethernet cable.

Q: How can I test an Ethernet?

A: This depends on what level you want to test. The most basic test (a.k.a., "the fire test") is to connect a pair of devices to the network and see if they can communicate with each other. If you want to test the electrical integrity of the wire (i.e., will it carry a signal properly), a TDR or cable scanner that incorporates TDR and other functions, would be the most comprehensive tool. If you need to test the performance or troubleshoot protocol transmission problems, you will need special and usually very expensive software, usually coupled with custom hardware, to capture, optionally filter, and analyze the network packets. Also, see the answer to the question above.

Q: What is a "TDR"?

A: A Time-Domain Reflectometer is a tool used to detect cable faults. This device operates by sending a brief signal pulse down the cable and looking for its reflection to bounce back. By analyzing the reflected pulse, it is possible to make judgments about the quality of the cable segment. More advanced units can not only detect and identify the nature of the problem, but give a reasonably accurate indication of the problem's location (distance from the point of the test). There is also a device known as an OTDR, which is an Optical Time-Domain Reflectometer for fiber-optic cables.

Q: What is a "BERT"?

A: Bit Error Rate Tester. This equipment is used to analyze the amount and types of errors that occur on a cable segment.

Q: What (free) tools are there to monitor/decode/etc an Ethernet?

- A: There are many built into most DOS, Unix and other operating systems. For example, the ping command can be used to determine if a given host is alive, and will also tell you the round trip transmission time. The command "ifconfig" will tell you the status of the network interfaces. "netstat" will summarize statistics for network usage.

DOS commands (through Windows DOS application) are:

ARP

Displays and modifies the IP-to-Physical address translation tables used by address resolution protocol (ARP).

ARP -a [inet_addr] [-N if_addr]

- a Displays current ARP entries by interrogating the current protocol data. If inet_addr is specified, the IP and Physical addresses for only the specified computer are displayed. If more than one network interface uses ARP, entries for each ARP table are displayed.
- g Same as -a.
- inet_addr Specifies an internet address.
- N if_addr Displays the ARP entries for the network interface specified by if_addr.
- d Deletes the host specified by inet_addr.
- s Adds the host and associates the Internet address inet_addr with the Physical address eth_addr. The Physical address is given as 6 hexadecimal bytes separated by hyphens. The entry is permanent.
- eth_addr Specifies a physical address.
- if_addr If present, this specifies the Internet address of the interface whose address translation table should be modified. If not present, the first applicable interface will be used.

Example:

- > arp -s 157.55.85.212 00-aa-00-62-c6-09 Adds a static entry.
- > arp -a Displays the arp table.

FTP

Transfers files to and from a computer running an FTP server service (sometimes called a daemon). FTP can be used interactively.

FTP [-v] [-d] [-i] [-n] [-g] [-s:filename] [-a] [-w:window size] [-A] [host]

- v Suppresses display of remote server responses.
- n Suppresses auto-login upon initial connection.
- i Turns off interactive prompting during multiple file transfers.
- d Enables debugging.
- g Disables filename globbing (see GLOB command).
- s:filename Specifies a text file containing FTP commands; the commands will automatically run after FTP starts.
- a Use any local interface when binding data connection.
- A login as anonymous.
- w:buffer size Overrides the default transfer buffer size of 4096.
- host Specifies the host name or IP address of the remote host to connect to.

Notes:

- mget and mput commands take y/n/q for yes/no/quit.
- Use Control-C to abort commands.

NET CONFIG	Displays your current workgroup settings.
NET DIAG	Runs the Microsoft Network Diagnostics program to display diagnostic information about your network.
NET HELP	Provides information about commands and error messages.
NET INIT	Loads protocol and network-adaptor drivers without binding them to Protocol Manager.
NET LOGOFF	Breaks the connection between your computer and the shared resources to which it is connected.
NET LOGON	Identifies you as a member of a workgroup.
NET PASSWORD	Changes your logon password.
NET PRINT	Displays information about print queues and controls print jobs.
NET START	Starts services.
NET STOP	Stops services.
NET TIME	Displays the time on or synchronizes your computer's clock with the clock on a Microsoft Windows for Workgroups, Windows NT, Windows 95, or NetWare time server.
NET USE	Connects to or disconnects from a shared resource or displays information about connections.
NET VER	Displays the type and version number of the workgroup redirector you are using.
NET VIEW	Displays a list of computers that share resources or a list of shared resources on a specific computer.

For more information about a specific Microsoft NET command, type the command name followed by */?* (for example, NET VIEW */?*).

PING

PING	<code>[-t] [-a] [-n count] [-l size] [-f] [-i TTL] [-v TOS] [-r count] [-s count] [[-j host-list] [-k host-list]] [-w timeout] destination-list</code>
-t	Ping the specified host until stopped. To see statistics and continue - type Control-Break; To stop - type Control-C.
-a	Resolve addresses to hostnames.
-n count	Number of echo requests to send.
-l size	Send buffer size.
-f	Set Don't Fragment flag in packet.
-i TTL	Time To Live.
-v TOS	Type Of Service.

-r count Record route for count hops.
-s count Timestamp for count hops.
-j host-list Loose source route along host-list.
-k host-list Strict source route along host-list.
-w timeout Timeout in milliseconds to wait for each reply.

ROUTE

Manipulates network routing tables.

ROUTE [-f] [command [destination] [MASK netmask] [gateway] [METRIC metric]]

-f Clears the routing tables of all gateway entries. If this is used in conjunction with one of the commands, the tables are cleared prior to running the command.

command Must be one of four:
PRINT Prints a route
ADD Adds a route
DELETE Deletes a route
CHANGE Modifies an existing route

destination Specifies the destination host.

MASK Specifies that the next parameter is the 'netmask' value.

netmask Specifies a subnet mask value to be associated with this route entry. If not specified, it defaults to 255.255.255.255.

gateway Specifies gateway.

METRIC Specifies that the next parameter 'metric' is the cost for this destination

All symbolic names used for destination are looked up in the network database file NETWORKS. The symbolic names for gateway are looked up in the host name database file HOSTS.

If the command is PRINT or DELETE, wildcards may be used for the destination and gateway, or the gateway argument may be omitted.

Diagnostic Notes:

Invalid MASK generates an error, that is when (DEST & MASK) != DEST.

Example> route ADD 157.0.0.0 MASK 155.0.0.0 157.55.80.1
The route addition failed: 87

Examples:

```
> route PRINT
> route ADD 157.0.0.0 MASK 255.0.0.0 157.55.80.1 METRIC 3
      ^destination      ^mask      ^gateway      ^metric
> route PRINT
> route DELETE 157.0.0.0
> route PRINT
```

SNMP

Starts SNMP agent

- close Closes previously running instance of snmp
- help Displays SNMP help dialog box

TELNET

Opens telnet window

TRACERT

TRACERT [-d] [-h maximum_hops] [-j host-list] [-w timeout] target_name

- d Do not resolve addresses to hostnames.
- h maximum_hops Maximum number of hops to search for target.
- j host-list Loose source route along host-list.
- w timeout Wait timeout milliseconds for each reply.

WINIPCFG

Opens IP configuration window

- /All - Display detailed information
- /Batch - [filename] Write to file or .\winipcfg.out
- /renew_all - Renew all adapters
- /release_all - Release all adapters
- /renew N - Renew adapter N
- /release N - Release adapter N

Q: What books are good about Ethernet LAN's?

A: The IEEE 802.3 documents are considered the definitive source for information on Ethernet. However, these may not be suitable for all levels of users. Surprisingly, there are few good books specifically dealing with Ethernet LANs, but here are a few that you might find useful:

Local Area Networks, An introduction to the technology by John E. McNamara, published by Digital Press, 1985 165 pps. with index and glossary, \$29.00 ISBN 0-932376-79-7, Digital Press part number EY-00051-DP.

Network Troubleshooting Guide by Digital Equipment Corporation, August 1990 Approx. 278 pps. with index and glossary, \$95.00 Digital Press part number EK-339AB-GD-002.

These books and others are recommended in the network reading list, net-read.txt, from ftp.utexas.edu.

Q: Where can I get IEEE802.x docs online?

A: Not available online. IEEE documents can be ordered directly from the IEEE themselves.
You can contact them at:

Institute of Electrical and Electronic Engineers 445 Hoes Lane P.O. Box 1331 Piscataway,
NJ 08855-1331 U.S.A. (800) 678-IEEE

Q: Where can I get EIA/TIA docs online?

A: Not available online They can be ordered from:

Global Engineering 800-854-7179

Appendix D - Rear Panel Data Connectors

The following figures illustrate the pin structure for all rear panel data connections. All figures are oriented as a customer would view them, facing the rear panel. DC power connection information is found in Section 3.7 of the manual.

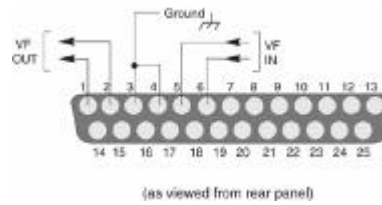

Figure D-1: VF Port Connection

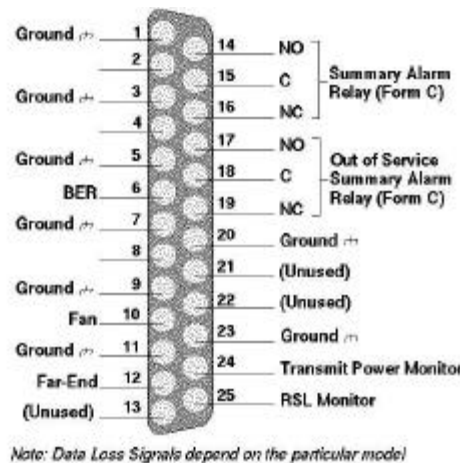
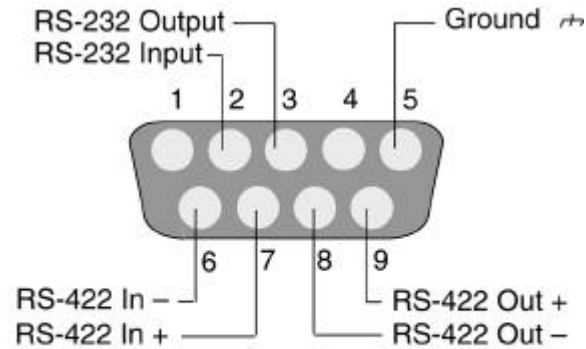

Figure D-2: Alarm Port Connections



(as viewed from rear panel)

Figure D-3: Diagnostic Port 9-Pin D-Style Connector

Do NOT use both the RS-232 and RS-422 connections at the same time!

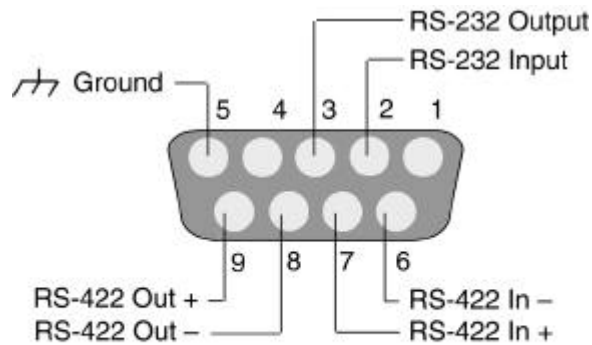

(as viewed from rear panel)

Figure D-4: AUX DATA Port 9-Pin D-Style Connector

Do NOT use both the RS-232 and RS-422 connections at the same time!

Appendix E – Installation and Troubleshooting Guide

(Foldout after this page)



Your Notes on the *Tsunami* Radio

Index

1	
10BaseT.....	2-2, 4-2, 5-11
A	
AC.....	3-18
Accessories	2-23
AIS.....	2-9
Alarm connections	3-41
Alarm interface	3-42
Alarms	3-32
Alignment, antenna	3-22
AMI	2-9
Antenna.....	2-4, 3-3, 3-23, 3-32, 3-35, 4-8, 4-18
Antenna connection	3-19
Antenna installation	3-21
Antenna planning	3-10
ARP	5-18
Auto-Negotiation	2-2, 4-2
Availability calculation.....	3-7
B	
B8ZS.....	2-9
Balun.....	2-9
Bit Error Rate	2-15, 3-7, 3-36, 3-42, 4-8, 4-16
Bridge	5-13
Buffer.....	2-8, 5-1
C	
Calculations	3-5
Caution	1-2
Channel plan	3-12, 3-25
Coaxial cable	3-20
Code.....	3-26
Coding	2-3
Collision	5-15, 5-16
Collisions	2-15
Compression	2-21
Connections	2-8, 2-10, 2-17, 2-19, 2-20, 3-24, 5-1
Container	3-1
Controls	2-16
CRC	5-10
D	
Data Loss	2-15
DC	3-9, 3-16
Delay.....	5-1
Digital Capacity	2-8
DIP switch	2-21, 3-27, 5-2
DIP switch settings	3-25
Dispersive fade	2-5, 3-6

Duplex	2-21, 5-1
E	
EIRP	3-28
Environment	2-11
Error LED	3-37
Errors	4-16
Ethernet.....	5-8
Ethernet packet	5-9
F	
Fade margin	3-6
Fans.....	4-13
Filtering	2-8, 2-21, 5-1
Frequency	3-12, 4-3
Frequency plan determination.....	3-8
Frequency Plans.....	2-6, 2-7
Fresnel	3-4
Front panel.....	2-13
FTP	5-19
Full Duplex	2-2, 4-2
G	
Grounding	3-16
H	
Hub	2-2, 4-2, 5-13
I	
Icons	1-2
IEEE	5-22
Installation	1-1, 2-23, 3-3, 3-27
Installation and Troubleshooting Guide.....	5-25
Interference.....	4-17
ISO.....	5-17
ISO 9000.....	i
L	
LAN.....	2-8
Layer.....	5-8
Learning.....	5-13
Line-of-sight	3-4
Link budget.....	3-5
Loopback	2-8, 2-9, 3-36, 4-9, 4-16
M	
MAC address	5-10
Mechanical.....	2-12
Mounting	3-14
Mute.....	2-21, 3-42
MUTE.....	2-15
N	
Note	1-2

O

Orderwire	2-10, 2-20, 2-22, 3-27, 3-32, 3-38, 3-39, 3-40
OSI Model	5-8
Output power	3-29, 3-30
Output power, adjust	3-33, 3-34, 3-35

P

Path	3-4
Path planning	3-10
PING	5-20
Power	2-3, 2-11, 2-23, 3-3, 3-15, 3-35, 4-8, 4-18
Power connection	3-18
Power connection, DC	3-16
Power supply planning	3-9
Professional installation	iii, 1-1

R

Rear panel	2-18, 5-23
Receive signal level	2-14, 2-16, 3-3, 3-5, 3-21, 3-22, 3-23, 3-31, 3-42, 4-8, 4-19
Receiver	2-4
Regulatory	iii, 2-12
REN	3-38
Repair	4-6
Repeater	5-12
Repeater configurations	3-46
Response time	2-2, 4-2
Response Time	2-2
RF filter	3-25
ROUTE	5-20
Router	5-14
RS-232/RS-422	2-20, 3-43, 3-44, 3-45, 3-46
RSL	3-23

S

Shipping	2-23, 3-1
SNMP	5-21
Spares	4-4
Spreading code	3-26
Subnet	5-12
Switch	2-2, 4-2, 5-13
Switches	4-3
Synchronization	4-12
System	2-5, 2-6, 2-7

T

Technical support	4-5
Telephone	3-38
TELNET	5-21
Test	2-10, 2-14
Tips	1-2
Tools	3-11
Traffic	5-17
Transmission line	3-20
Transmitter	2-3, 3-33

Troubleshooting.....	4-1, 5-25
Turn-up.....	3-27
Twisted pair.....	5-11
U	
UTP.....	5-11
W	
Warranty.....	v
Winipcfg.....	5-22

For ISO Purposes -
Last Page of this Manual